

W. Hayes Street Improvement Project

GRADING, PAVING, ROADSIDE DEVELOPMENT, SIGNING, PAVEMENT MARKINGS, SIGNALS

PREPARED FOR:
City of Woodburn
 Project Number: 2015-001-20
 March 7, 2022

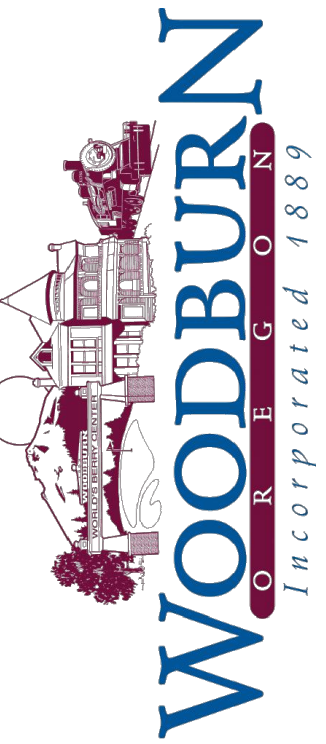

KITTELSON & ASSOCIATES
 851 SW 6TH AVENUE, SUITE 600
 PORTLAND, OR 97204
 P 503.228.5230 F 503.273.8169

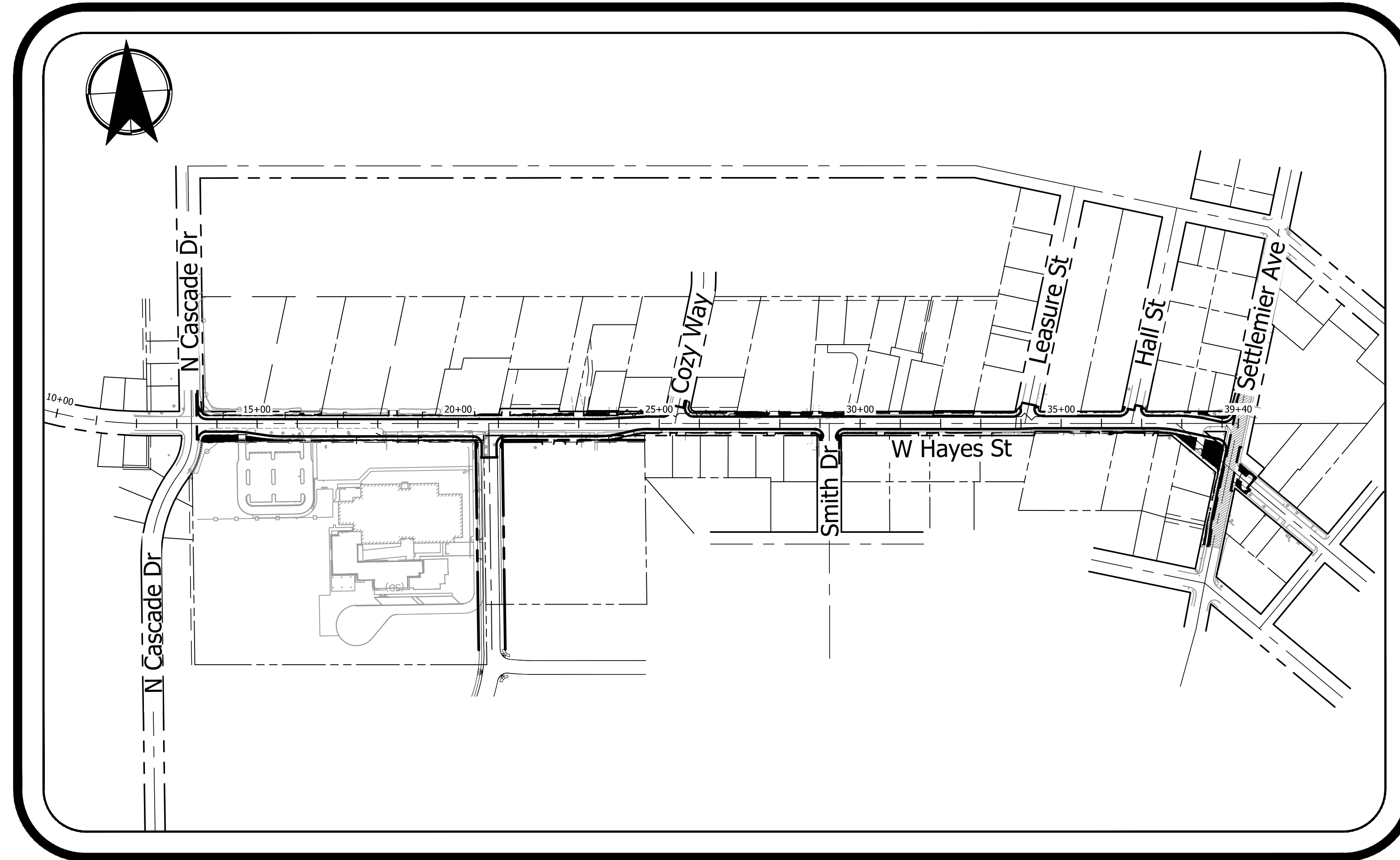

SITE MAP

SCALE: NTS

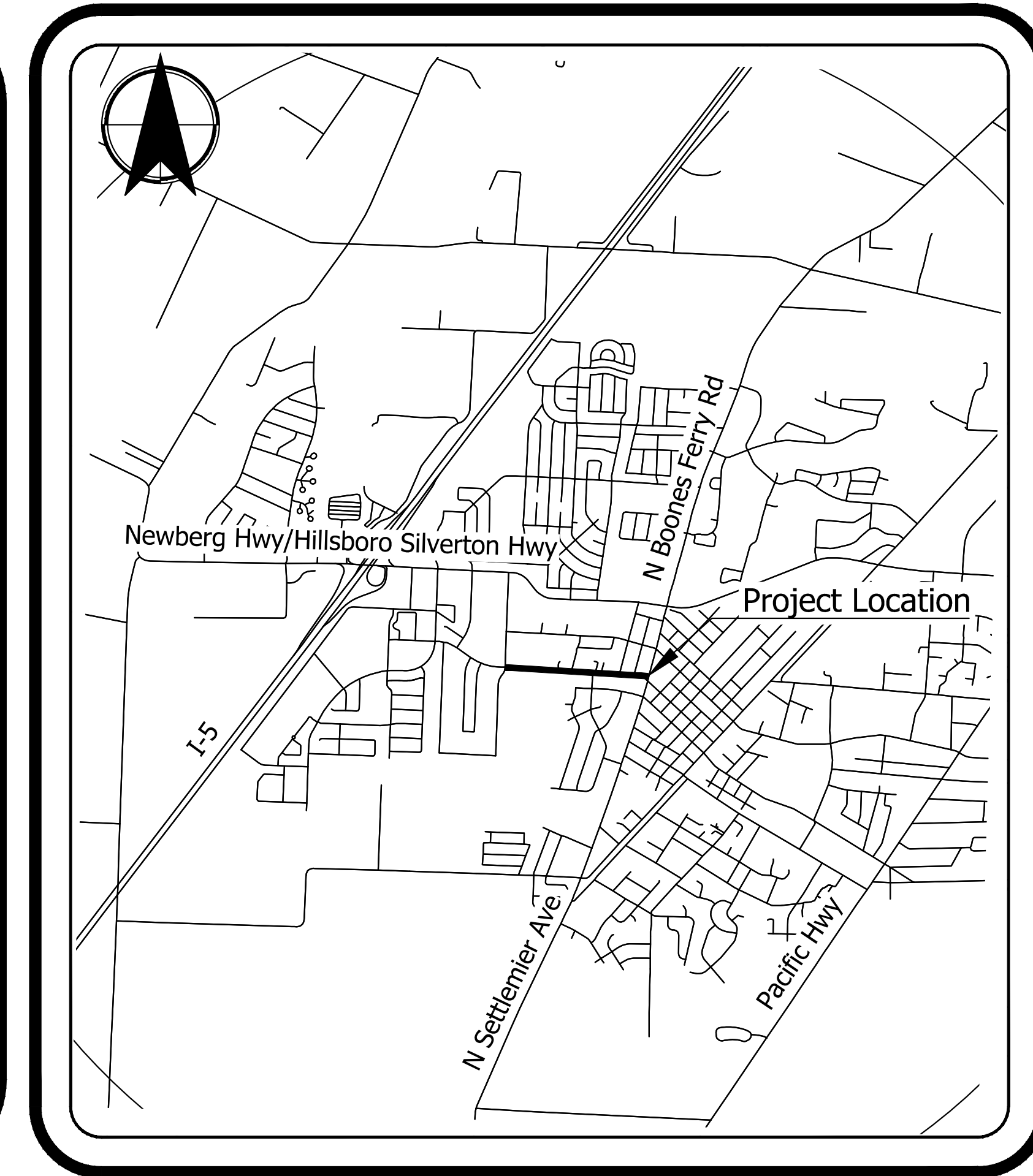

VICINITY MAP

SCALE: NTS

BASIS OF STATIONING:

The centerline of west Hayes St was derived by holding the found monument marking the southwest corner of the George Leasure Donation Land Claim (DLC) #78, and found monuments as noted at stations 25+02.72/30.00' LT, 26+91.12/20.00' LT, 30+70.15/30.00' LT, 32+82.80/30.00' LT, and 36+38.18/30.00' RT. The centerline was extended easterly to the centerline of Settlemier St.

DATUM:

HORIZONTAL DATUM
 The Oregon North State Plane coordinate system, (Zone 3601) NAD83 (2011) with a combined scale factor of 1.0001106037 international feet, based on information provided to the City of Woodburn by AKS Engineering and Forestry.

VERTICAL DATUM

Elevations are based on Marion County Control Point No. 9428, a brass disk in a monument box at the centerline-centerline intersection of W. Hayes Street and Cascade Drive. Benchmark Elevation = 186.42 feet (NAVD 88). Per the City of Woodburn requirements, project datum is to be on the NGVD 29 datum. Using NGS Vertcon software benchmark elevation = 183.07 (NGVD 29). All elevations shown are based on the NGVD 29 datum.

SITE INFORMATION:

Located in SE Quarter Of Section 12, Township 5 South, Range 2 West, And In SW Quarter Of Section 7, Township 5 South, Range 1 West, Willamette Meridian, City Of Woodburn, Marion County, Oregon

UTILITY NOTIFICATION:

ATTENTION: Oregon Law Requires You To Follow Rules Adopted By The Oregon Utility Notification Center. Those Rules Are Set Forth In OAR 952-001-0010 Through 952-001-0090. You May Obtain Copies Of The Rules By Calling The Center. (Note: The Telephone Number For The Oregon Utility Notification Center Is (503) 232-1987.)

PROJECT CONTACTS

OWNER
 CITY OF WOODBURN
 CONTACT: Dago Garcia, P.E.
 ADDRESS: 190 Garfield Street
 Woodburn, OR 97071
 PHONE: 503.982.5248
 EMAIL: dago.garcia@ci.woodburn.or.us

ENGINEER
 KITTELSON & ASSOCIATES, INC.
 CONTACT: Fred Wismer, P.E.
 ADDRESS: 851 SW 6th Avenue, Suite 600
 Portland, OR 97204
 PHONE: 503.535.7440
 EMAIL: fwisner@kittelton.com

ORS 92.044

This Design Complies With ORS 92.044 (7) In That No Utility Infrastructure Is Designed To Be Within One Foot Of A Survey Monument Location Shown On A Subdivision Or Partition Plat. No Design Modification Nor Final Field Location Change Shall Be Permitted If It Would Cause Any Utility Infrastructure To Be Placed Within The Prohibited Area.

Index of Sheets			
Sheet Number	Sheet Title	Sheet Number	Sheet Title
1	Cover Sheet	2E Thru 2E-14	Detailed Grading and Dimensioning
1A	Legend and Abbreviations	2G	Water Quality Plans
2A Thru 2A-2	Typical Sections	3 Thru 12	Street Plans
2B Thru 2B-6	Details	SS Thru SS-12	Signing and Striping
2C Thru 2C-6	Traffic Control Plans	TS Thru TS-6	Signal and RRFB Plans
2D Thru 2D-7	Grading and Erosion Plan	IC-1 and IC-3	Interconnect Plan
		IL Thru IL-5	Illumination

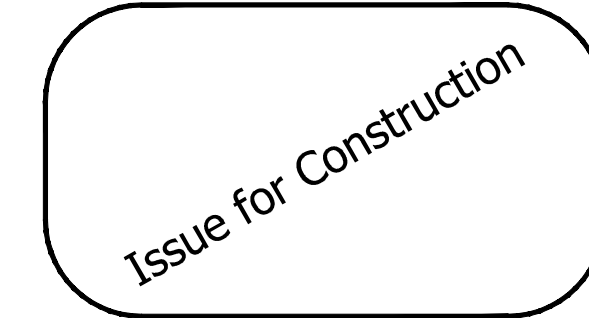

DATE	REVISION	APP'D
01/05/25/22 <td>ISSUE FOR CONSTRUCTION <td>FSW </td></td>	ISSUE FOR CONSTRUCTION <td>FSW </td>	FSW
	REVISION <td></td>	

Submission Date: 03/07/2022

Drawn: JCB/RMM Designed: NRS/JBK Checked: FSW

PROJECT NO. 2015-001-20

W. Hayes Street Improvements
 Cascade Avenue to Settlemier Avenue
 COVER SHEET

SHEET NO. 1

Plot Stamp: 5/25/2022 3:24:27 PM - Fred Wismer
 File: H:\24\24512 - W. Hayes Street\design\CD\CD-Cover-24512.dwg

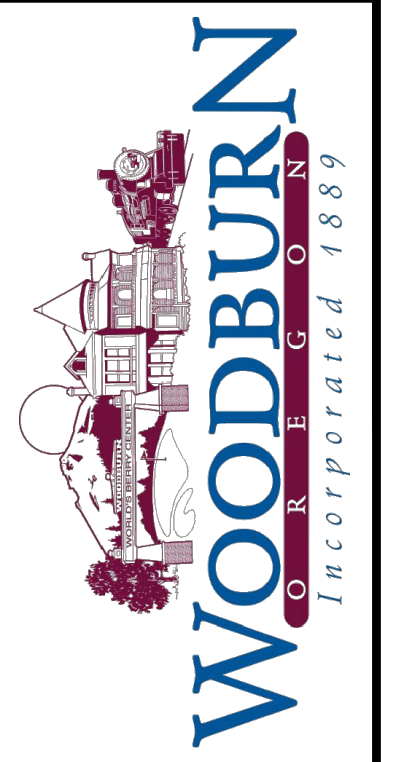

KITTELSON & ASSOCIATES
 851 SW 6TH AVENUE, SUITE 600
 PORTLAND, OR 97204
 P 503.228.5230 F 503.273.8169

NO.	DATE	REVISION	APP'D.
0	05/25/22	ISSUE FOR CONSTRUCTION	FSW

Submission Date: 03/07/2022
 Drawn: JCB/RMM, Designed: NRS/JBK, Checked: FSW

PROJECT NO. 2015-001-20

W. Hayes Street Improvements
 Cascade Avenue to Settlemier Avenue

TYPICAL SECTIONS

SHEET NO. 2A

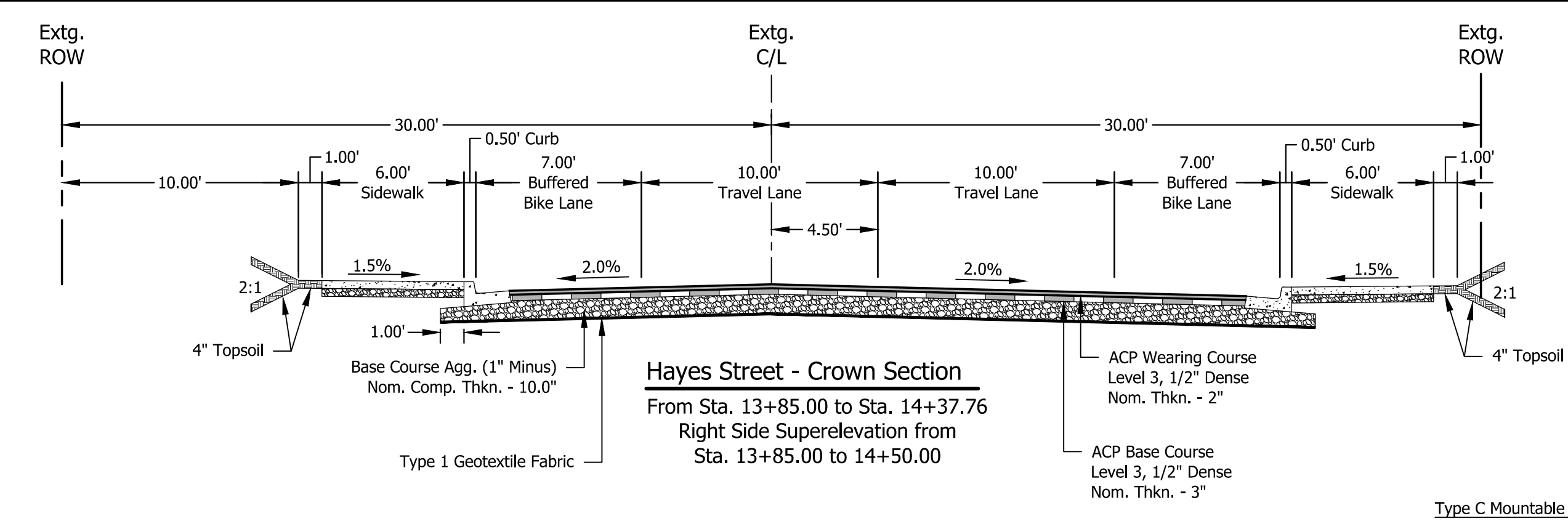

Type C Mountable curb - Center

Begin Sta.	End Sta.
21+63.27	22+10.20

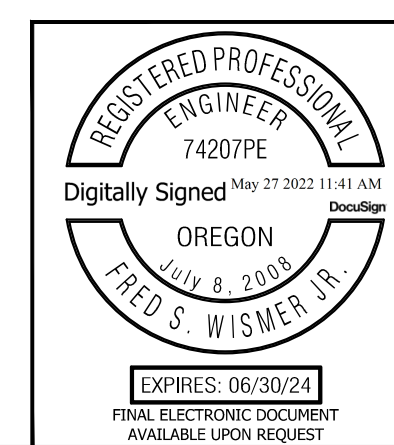
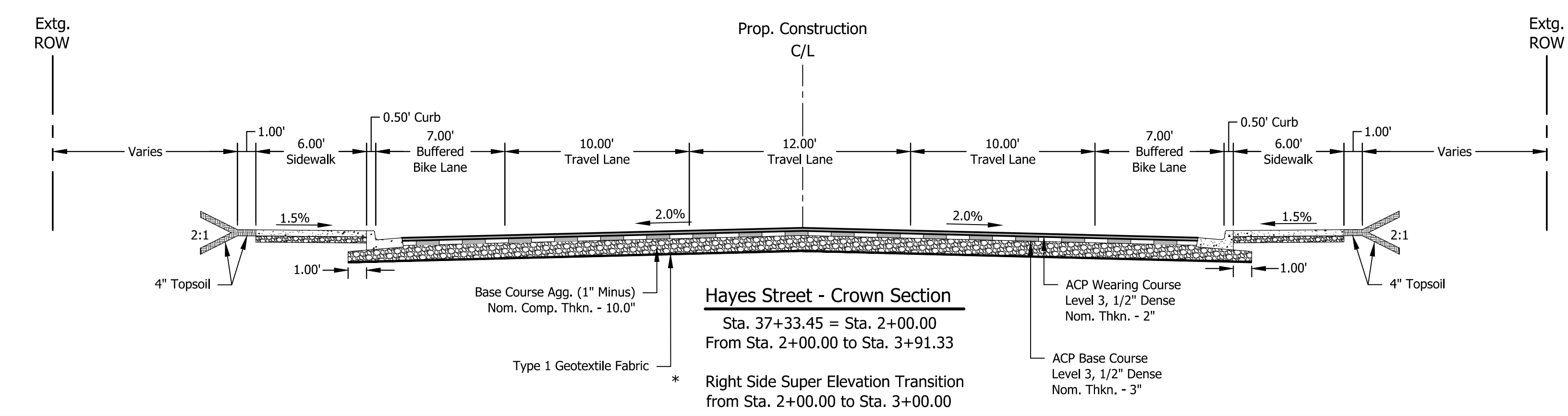
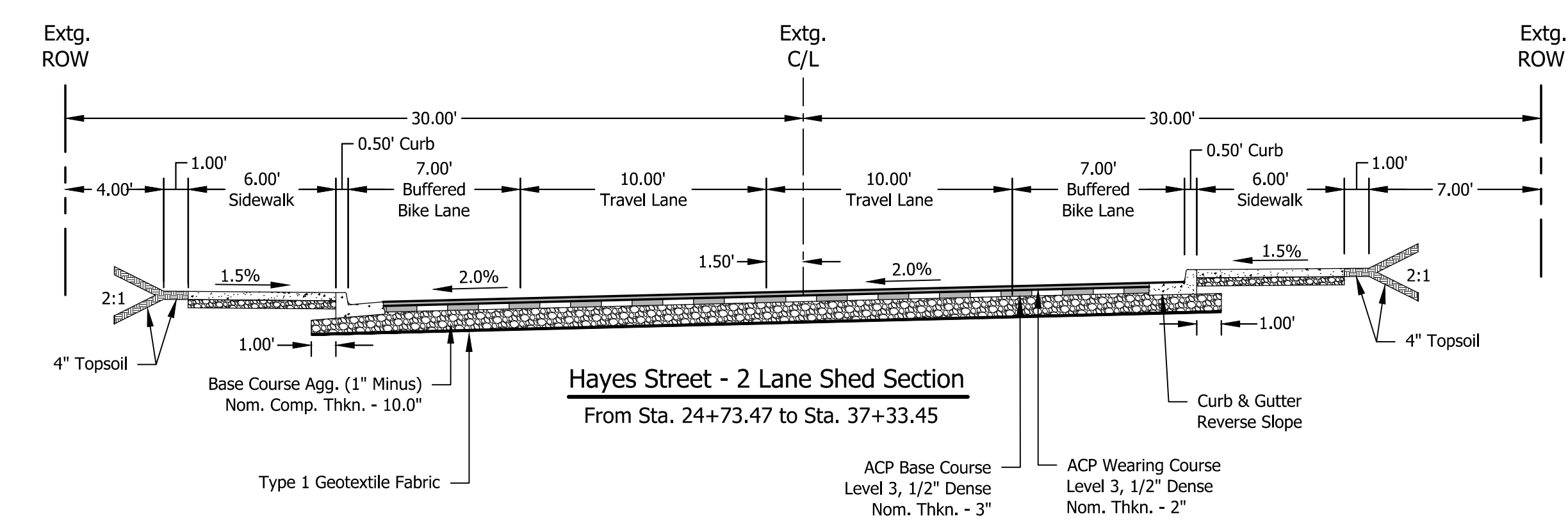
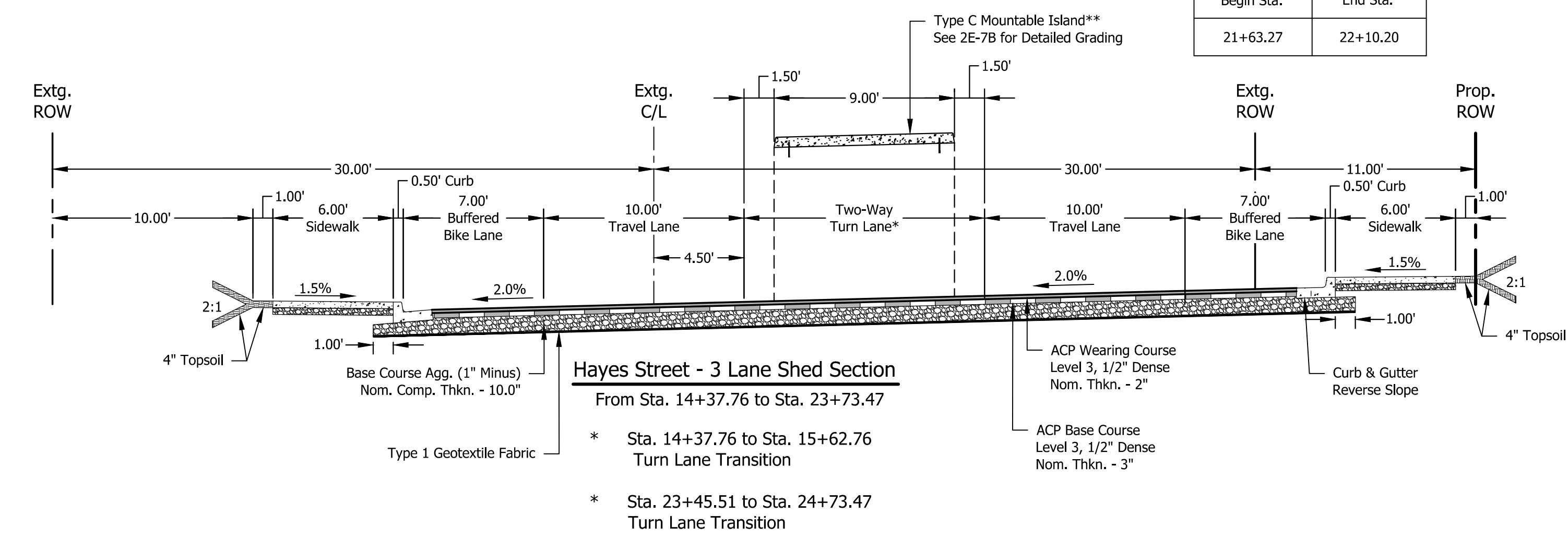

Plot Stamp: 5/25/2022 3:24:40 PM - Fred Wismer
 File: H:\24\24512 - W. Hayes Street\design\CD-Typicals-24512.dwg

Plot Stamp: 5/25/2022 3:24:46 PM - Fred Wismer
 File: H:\24\24512 - W. Hayes Street\design\CD\CD-Typicals-24512.dwg

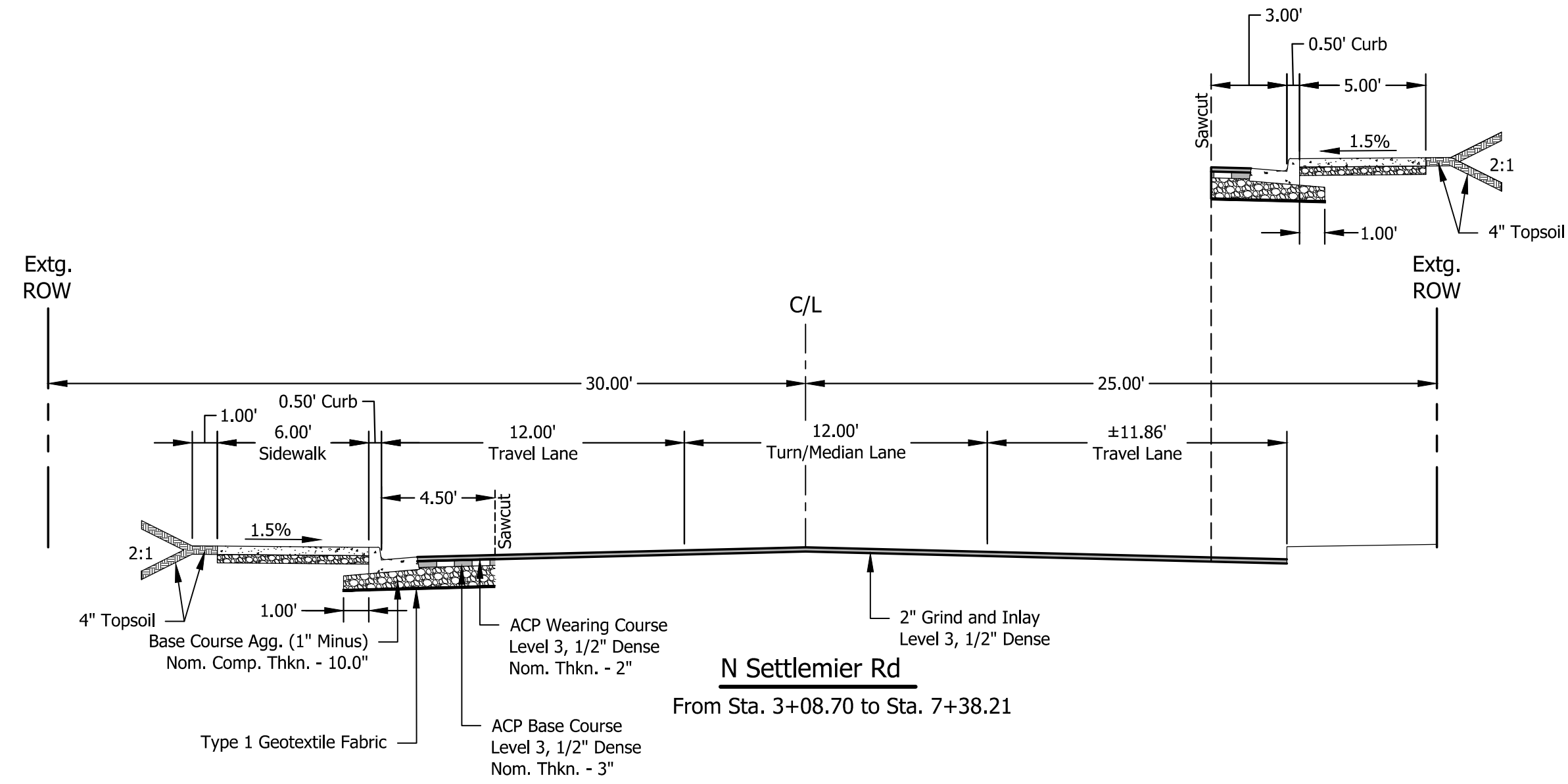

Sidewalk Replacement - Right

Begin Sta.	End Sta.
4+62.29	5+26.20
5+36.69	5+65.69
6+28.83	6+44.84

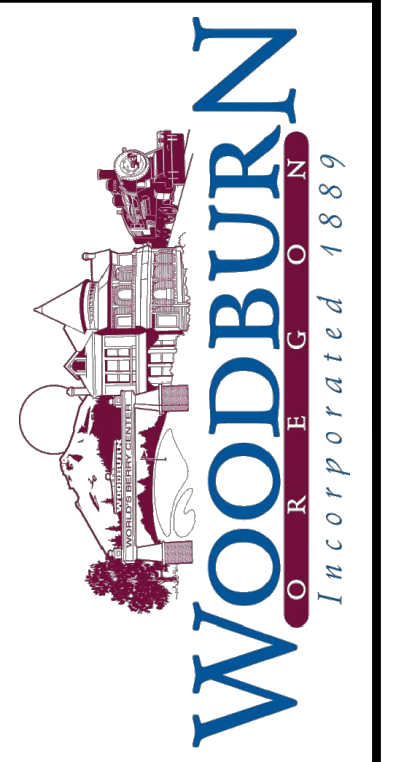
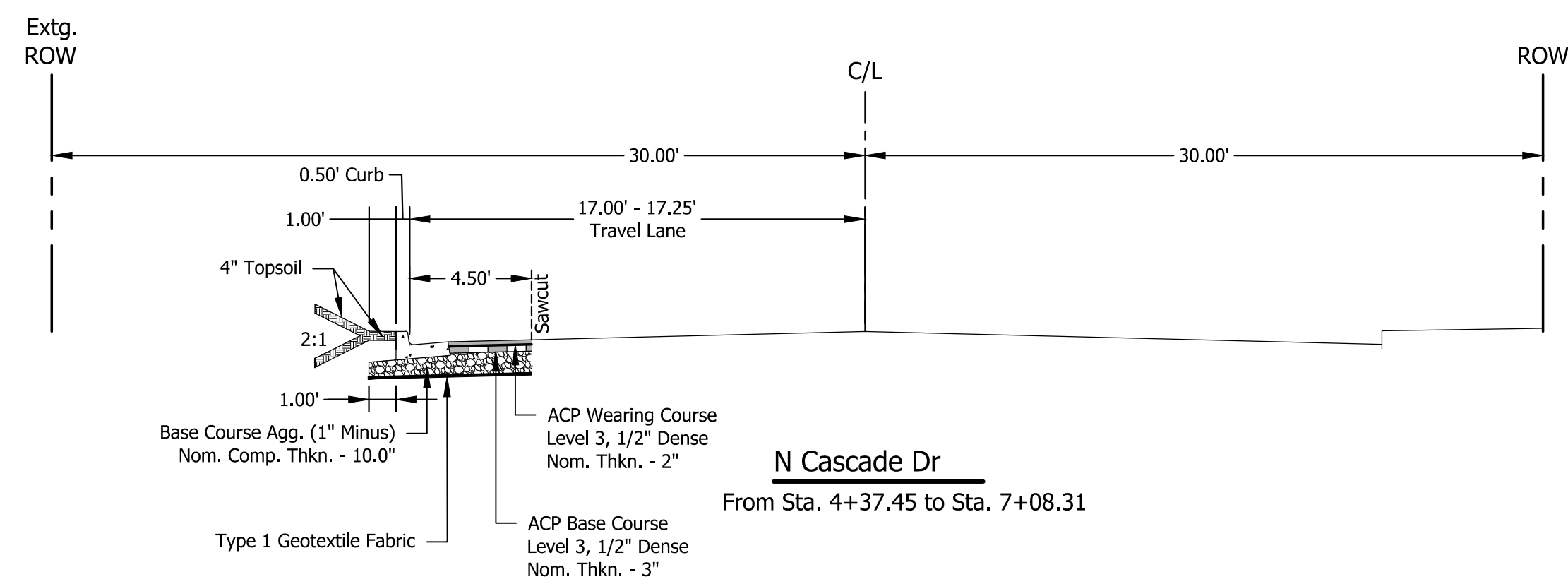

KITTELSON & ASSOCIATES
 851 SW 6TH AVENUE, SUITE 600
 PORTLAND, OR 97204
 P 503.228.5230 F 503.273.8169

REVISION	DATE	BY	APP'D
0	05/25/22	FSW	APP'D

Submission Date: 03/07/2022
 Drawn: JCB/RMM | Designed: NRS/JBK | Checked: FSW

PROJECT NO. 2015-001-20
W. Hayes Street Improvements
 Cascade Avenue to Settlemier Avenue
 TYPICAL SECTIONS

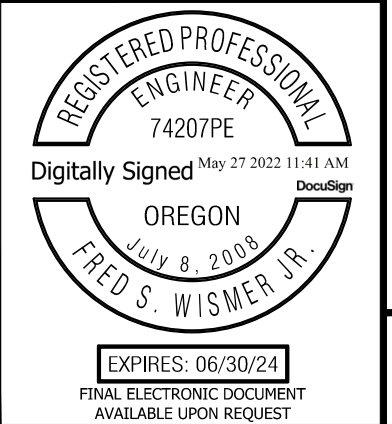

SHEET NO. 2A-2

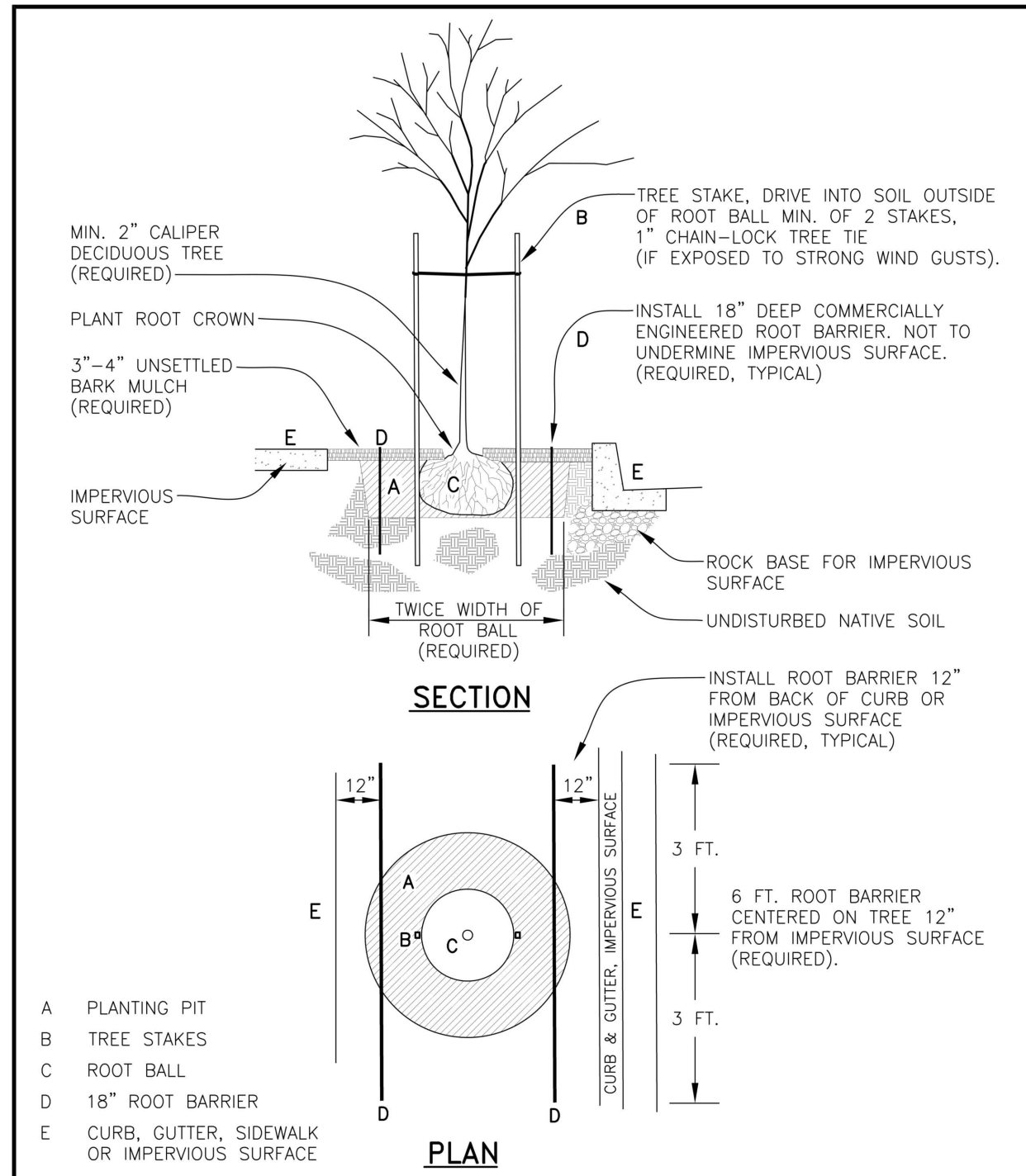

WOODBURN
 Incorporated 1889
 PUBLIC WORKS DEPARTMENT
 ENGINEERING DIVISION

**STREET TREE PLANTING
 NEW CONSTRUCTION**

REV: AUG. 2020
 SCALE: NTS
 DWG No. 1

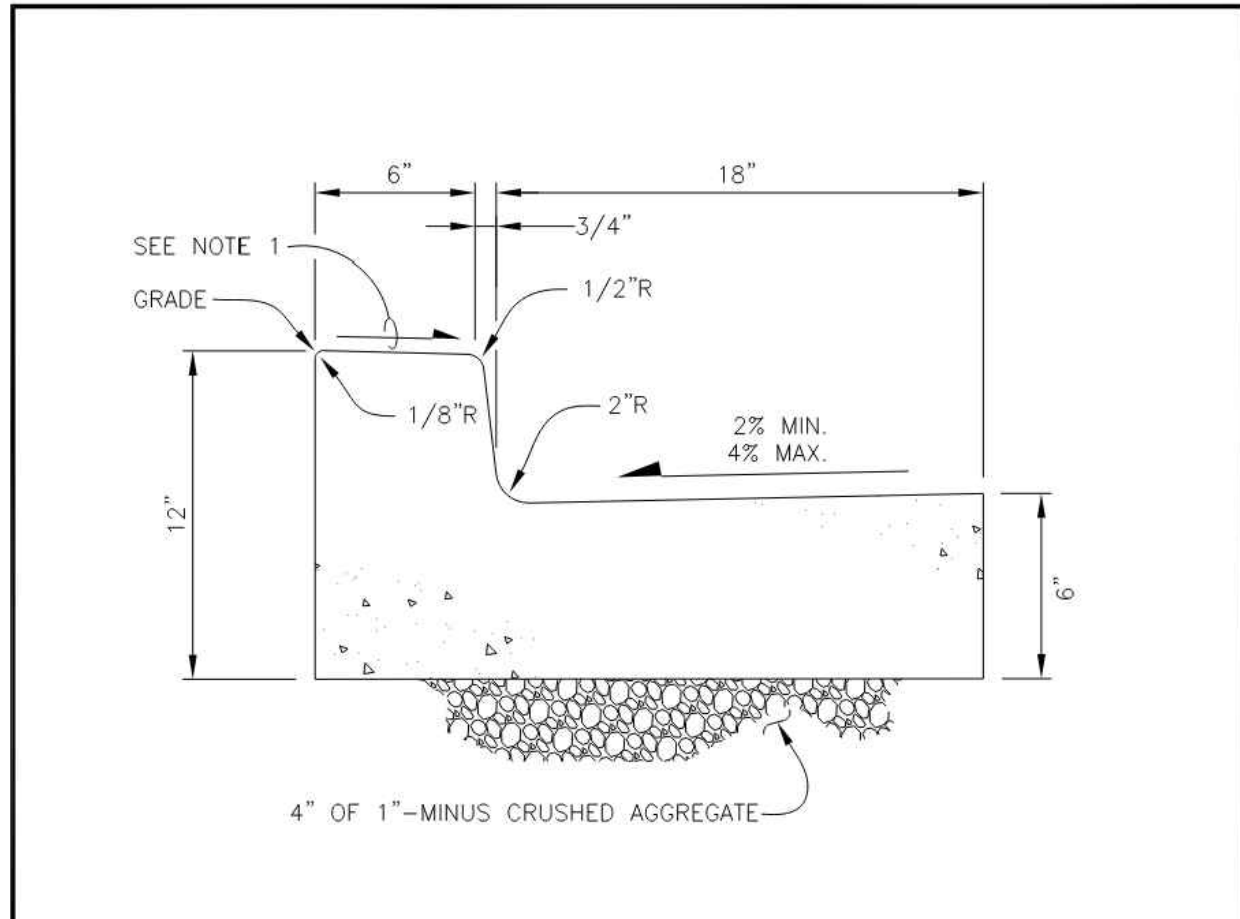

NOTES:

1. SLOPE CURB 0.02 FT/FT TO CURB FACE.
2. MATERIAL - 3500 PSI CONCRETE AT 28 DAYS.
3. REFERENCE TECHNICAL SPEC. SECTIONS 2000, 2300 AND 4100.
4. PLACE CONTRACTION JOINTS AT 15' MAX. INTERVALS AND SHALL EXTEND AT LEAST 50% THROUGH CURB.

WOODBURN
 Incorporated 1889
 PUBLIC WORKS DEPARTMENT
 ENGINEERING DIVISION

**TYPE 'A' CURB
 AND GUTTER**

REV: DEC. 2007
 SCALE: NTS
 DET No. 4100-1

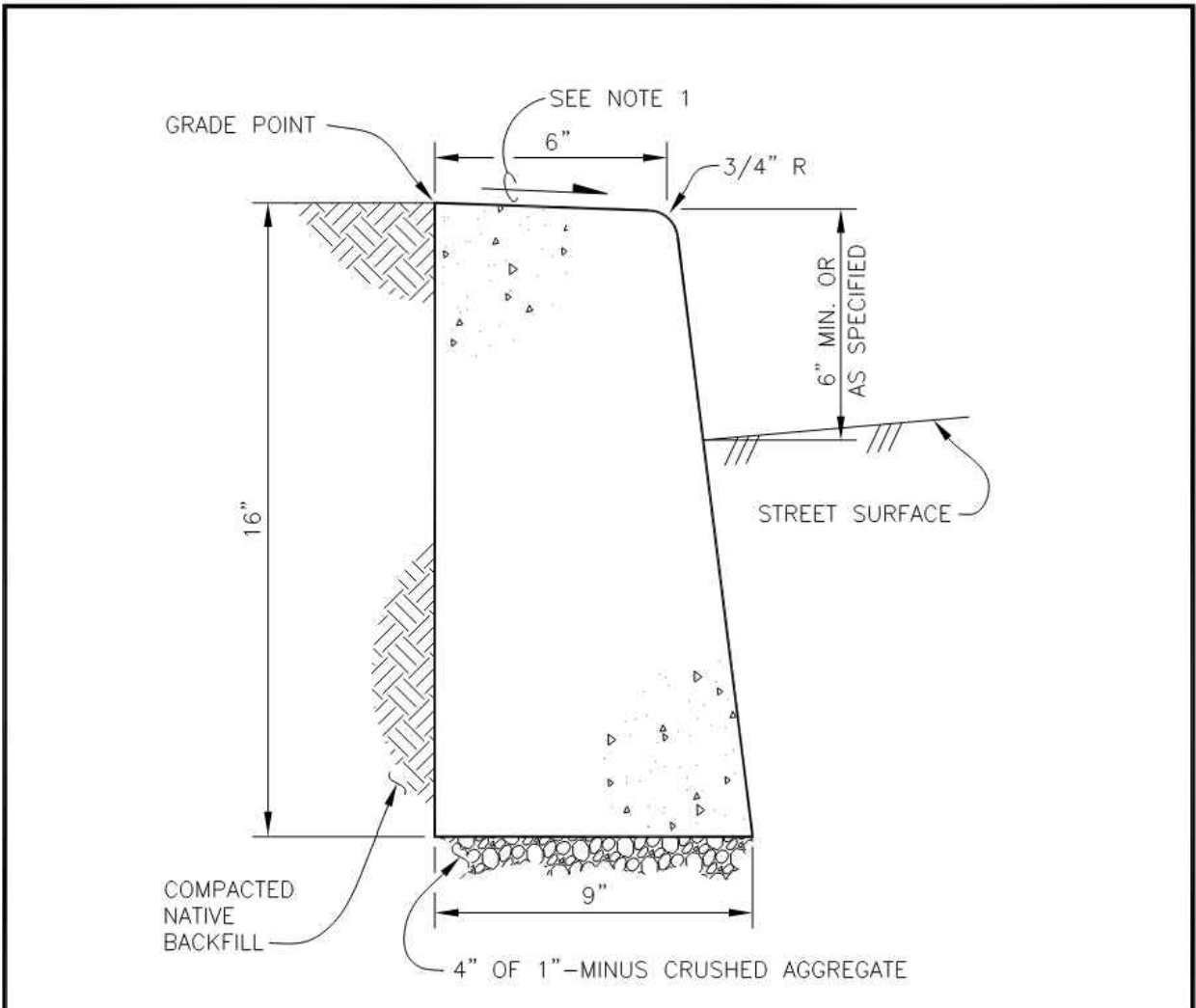

NOTES:

1. SLOPE CURB 0.02 FT/FT TO CURB FACE.
2. MATERIAL - 3500 PSI CONCRETE AT 28 DAYS.
3. REFERENCE TECHNICAL SPEC. SECTIONS 2000, 2300 AND 4100.
4. PLACE CONTRACTION JOINTS AT 15' MAX. INTERVALS AND SHALL EXTEND AT LEAST 50% THROUGH CURB.

WOODBURN
 Incorporated 1889
 PUBLIC WORKS DEPARTMENT
 ENGINEERING DIVISION

TYPE 'C' CURB

REV: DEC. 2007
 SCALE: NTS
 DET No. 4100-2

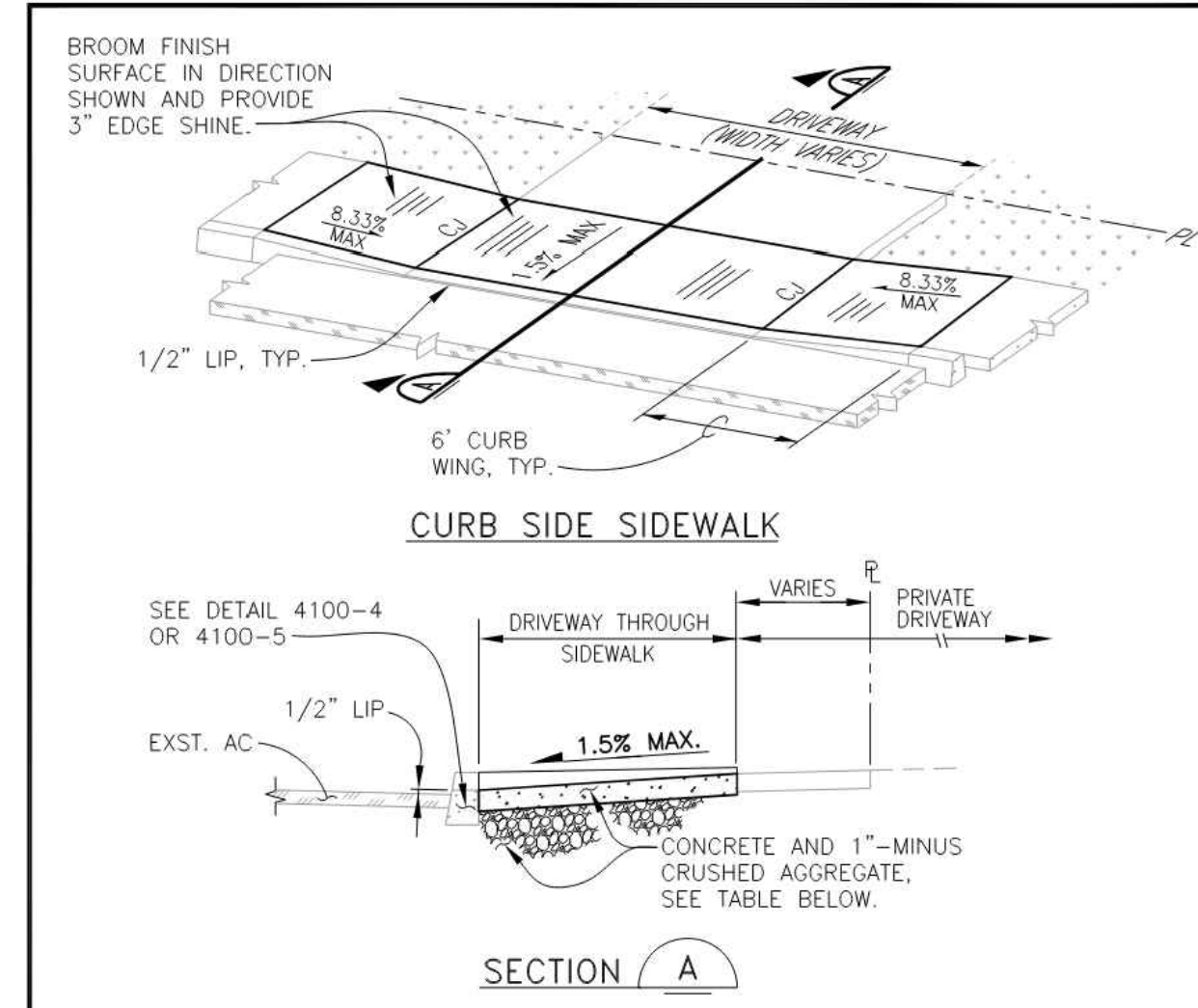

CONCRETE/AGGREGATE BASE THICKNESS AND REINFORCEMENT.

USE	CONC.	1"-MINUS CRUSHED AGGREGATE	REBAR
SINGLE FAMILY RESIDENTIAL	6"	4"	NONE
ALL OTHER	8"	6"	No.4 @ 12"O.C. EACH WAY

NOTES:

1. REFERENCE TECHNICAL SPEC. SECTION 4150.
2. PLACE CONSTRUCTION JOINTS AT 5' INTERVALS 1/3 THICKNESS.
3. MATERIAL - 3500 PSI CONCRETE AT 28 DAYS.

WOODBURN
 Incorporated 1889
 PUBLIC WORKS DEPARTMENT
 ENGINEERING DIVISION

**CURBSIDE
 SIDEWALK
 AT DRIVEWAY**

REV: MAY 2019
 SCALE: NTS
 DET No. 4150-3

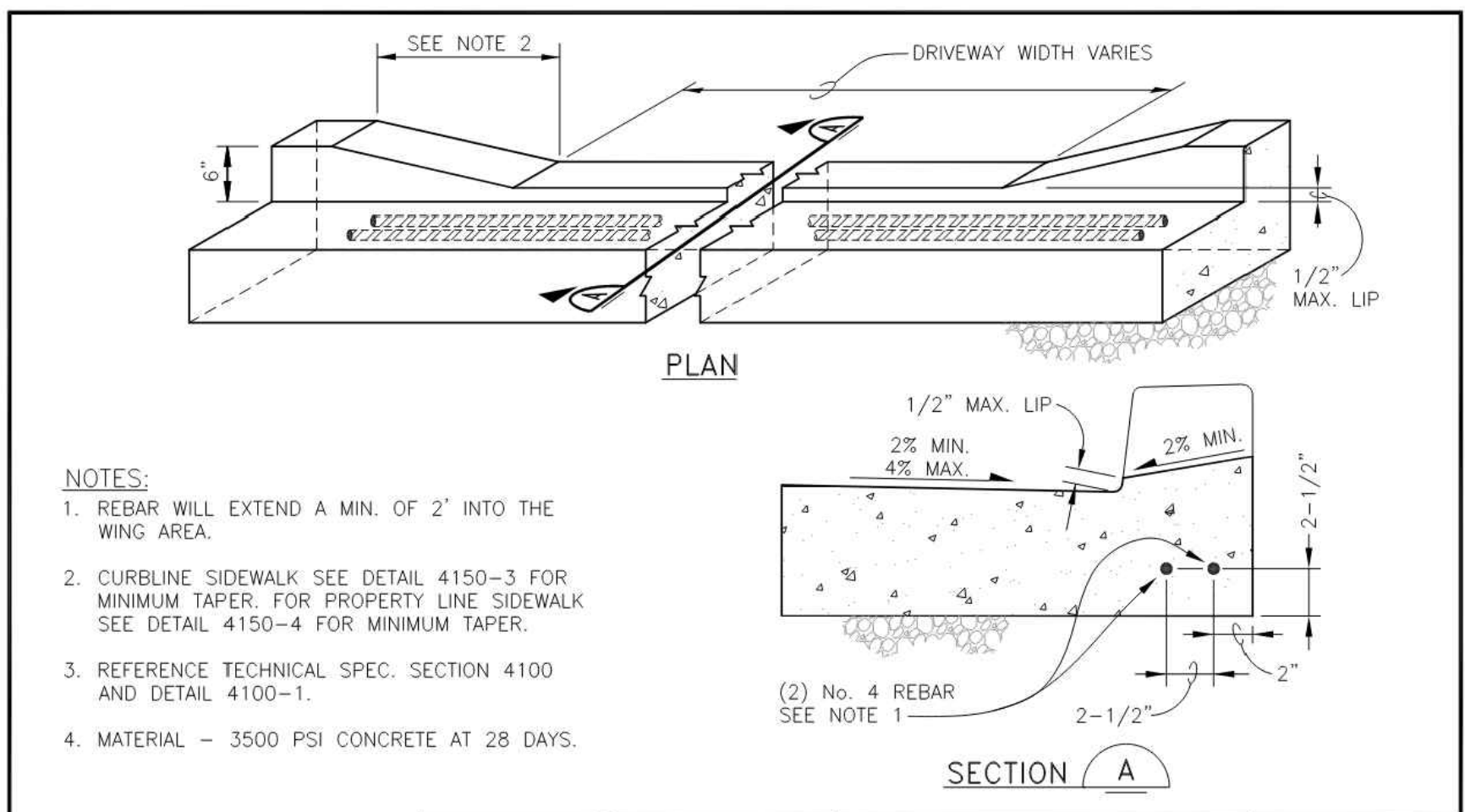

NOTES:

1. REBAR WILL EXTEND A MIN. OF 2' INTO THE WING AREA.
2. CURBLINE SIDEWALK SEE DETAIL 4150-3 FOR MINIMUM TAPER. FOR PROPERTY LINE SIDEWALK SEE DETAIL 4150-4 FOR MINIMUM TAPER.
3. REFERENCE TECHNICAL SPEC. SECTION 4100 AND DETAIL 4100-1.
4. MATERIAL - 3500 PSI CONCRETE AT 28 DAYS.

WOODBURN
 Incorporated 1889
 PUBLIC WORKS DEPARTMENT
 ENGINEERING DIVISION

**TYPE 'A' CURB
 AT DRIVEWAY**

REV: DEC. 2007
 SCALE: NTS
 DET No. 4100-4

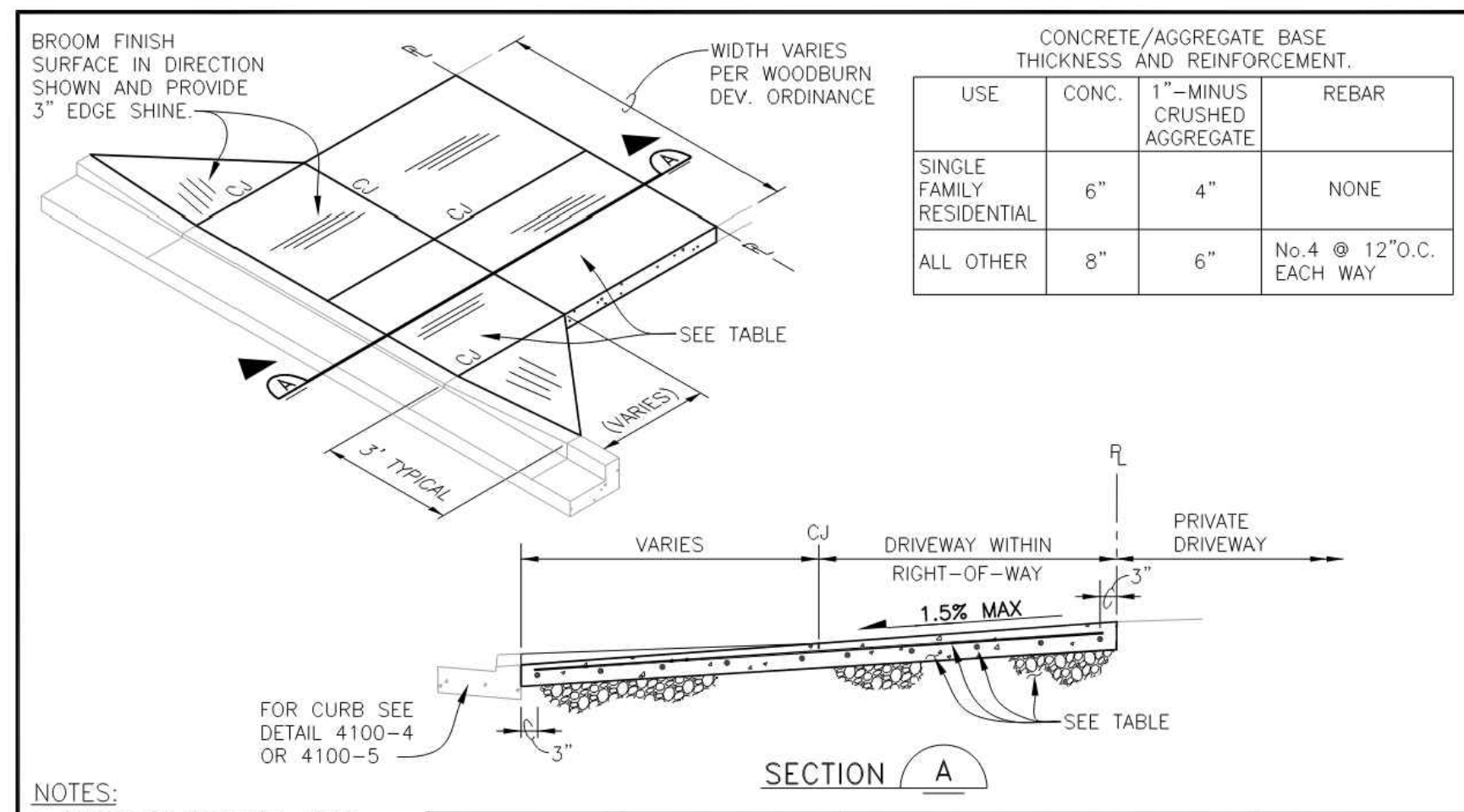

CONCRETE/AGGREGATE BASE THICKNESS AND REINFORCEMENT.

USE	CONC.	1"-MINUS CRUSHED AGGREGATE	REBAR
SINGLE FAMILY RESIDENTIAL	6"	4"	NONE
ALL OTHER	8"	6"	No.4 @ 12"O.C. EACH WAY

NOTES:

1. REFERENCE TECHNICAL SPEC. SECTION 4150.
2. EXPANSION JOINTS (EJ) SHALL BE 1/2" AC IMPREGNATED JOINT FILLER AT ALL DISSIMILAR VERTICAL SURFACES.
3. MATERIAL - 3500 PSI CONCRETE AT 28 DAYS.

WOODBURN
 Incorporated 1889
 PUBLIC WORKS DEPARTMENT
 ENGINEERING DIVISION

**DRIVEWAY
 APPROACH**

REV: MAY 2019
 SCALE: NTS
 DET No. 4150-1

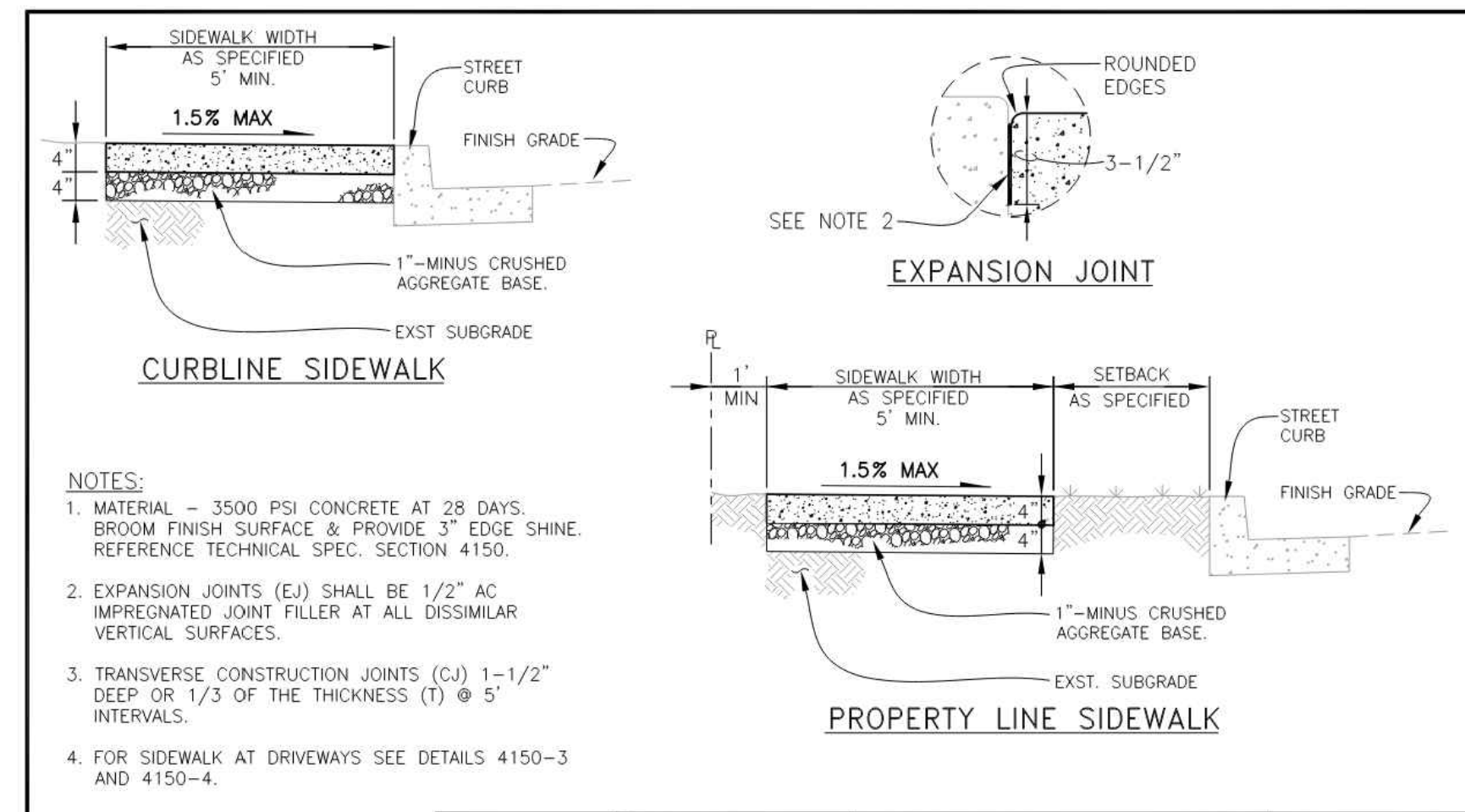

NOTES:

1. MATERIAL - 3500 PSI CONCRETE AT 28 DAYS. BROOM FINISH SURFACE & PROVIDE 3" EDGE SHINE. REFERENCE TECHNICAL SPEC. SECTION 4150.
2. EXPANSION JOINTS (EJ) SHALL BE 1/2" AC IMPREGNATED JOINT FILLER AT ALL DISSIMILAR VERTICAL SURFACES.
3. TRANSVERSE CONSTRUCTION JOINTS (CJ) 1-1/2" DEEP OR 1/3 OF THE THICKNESS (T) @ 5' INTERVALS.
4. FOR SIDEWALK AT DRIVEWAYS SEE DETAILS 4150-3 AND 4150-4.

WOODBURN
 Incorporated 1889
 PUBLIC WORKS DEPARTMENT
 ENGINEERING DIVISION

SIDEWALKS

REV: JULY 2018
 SCALE: NTS
 DET No. 4150-8

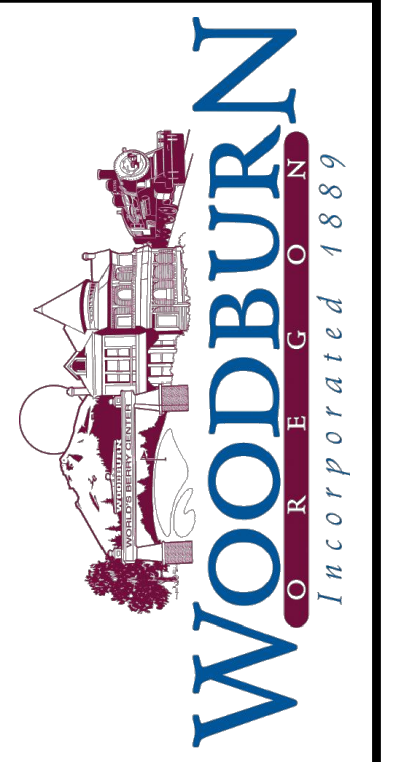

**KITTELSON
 & ASSOCIATES**

851 SW 6TH AVENUE, SUITE 600
 PORTLAND, OR 97204
 P 503.228.5230 F 503.273.8169

NO.	DATE	REVISION
0	05/25/22	ISSUE FOR CONSTRUCTION
		FWW
		APP'D

Submission Date: 03/07/2022
 Drawn: JCB/RMM
 Designed: NRS/JBK
 Checked: FSW
 PROJECT NO. 2015-001-20

**W. Hayes Street Improvements
 Cascade Avenue to Settlemier Avenue**

ROADWAY DETAILS

SHEET NO. 2B

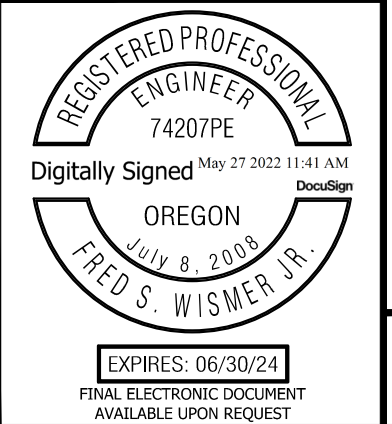

Plot Stamp: 5/25/2022 3:24:52 PM - Fred Wismer
 File: H:\24\24512 - W. Hayes Street\design\CD\CD-Details-24512.dwg

Plot Stamp: 5/25/2022 3:24:56 PM - Fred Wismer
 File: H:\24\241512 - W. Hayes Street\design_CD\CD-Details-241512.dwg

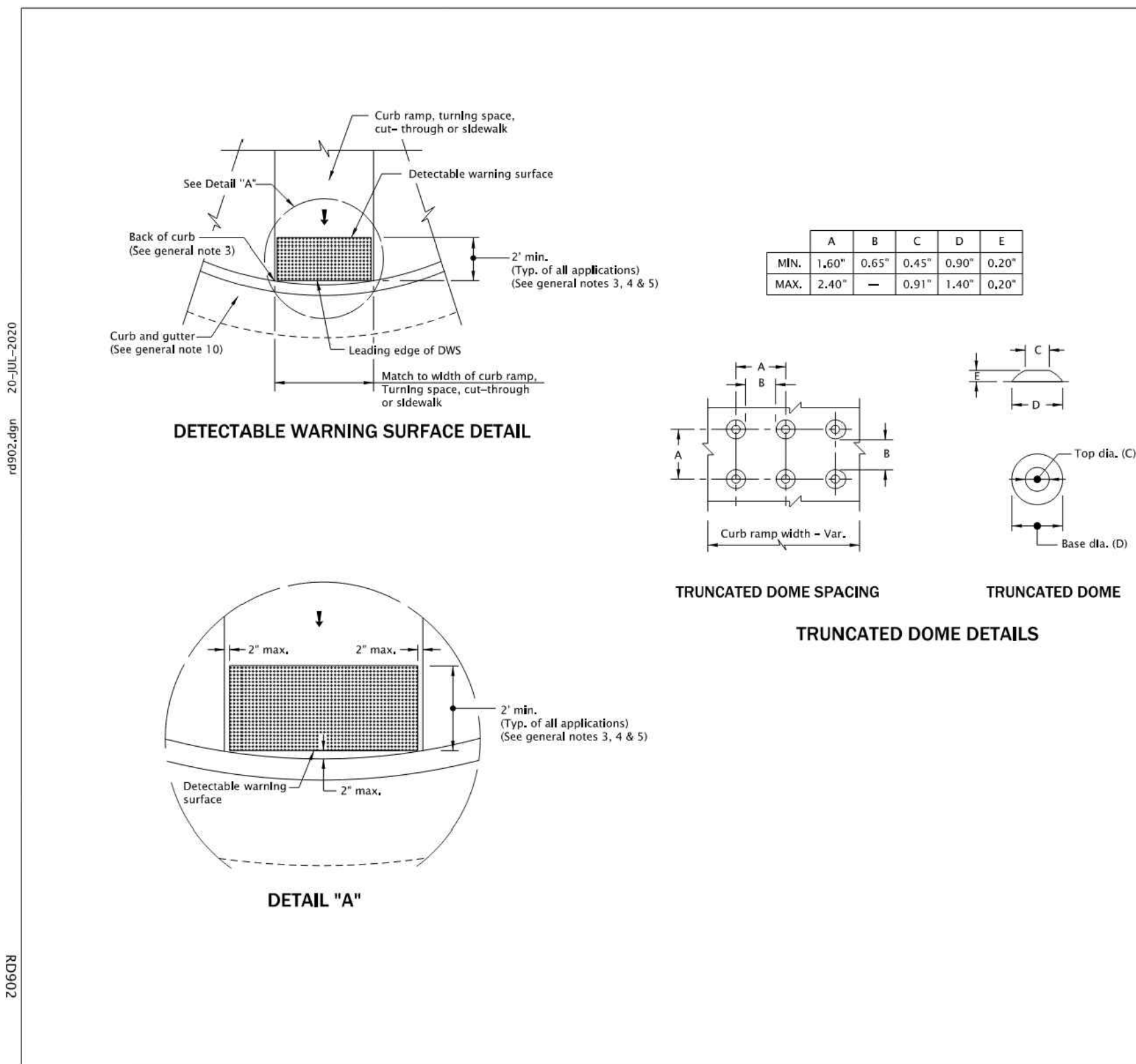

GENERAL NOTES FOR ALL DETAILS ON THIS SHEET:

- Detectable warning surface details & locations are based on applicable ODOT Standards.
- See project plans for details not shown. See Std. Dwg. RD700 & RD701 for curbs.
- The detectable warning surface shall extend the full width of the curb ramp opening, shared use path, blended transition, turning space, or other roadway entrance as applicable. A gap of up to 2 inches on each side of the detectable warning surface is permitted (measured at the leading edge of the detectable warning surface panels).
- Detectable warning surface shall be placed at the back of curb for a minimum depth of 2 ft. In the direction of pedestrian travel at curb ramps that are adjacent to traffic. Detectable warning surface may be radial or rectangular, but must comply with the truncated dome size and spacing standards. Detectable warning surface may be cut to meet necessary shape as shown in plans. Detectable warning surface across a grade break is prohibited.
- Color to be safety yellow if no color specified in construction note. Alternative colors require a design exception on or along state highways.
- Detectable warning surface shall be used in the following locations:
 - Curb ramps at street crossings.
 - Crossing Islands (Accessible Route Islands).
 - Rail crossings.
- Where public transportation stations (rail, bus, etc.) use platform boarding, detectable warning surface shall be placed along the full edge length of the station, when not protected by platform screens or guards, (see Std. Dwg. RD908).
- Detectable warning surface shall not be used on the following locations:
 - End of sidewalk transitions that are not at a crosswalk, (see Std. Dwg. RD950, RD952 & RD950).
 - Driveways, unless constructed with curb return or are signalized.
 - Parking lots, access aisles and passenger loading zones where curb ramp does not lead to vehicular way.
- Where no curb is present, the detectable warning surface shall be placed at the edge of the roadway.
- On or along state highways, curb and gutter is required at curb ramps.

LEGENDS:

- Detectable warning surface
- Cross slope 1.5% max. (Max. 2.0% finished surface slope) (Normal sidewalk cross slope)
- Running slope 7.5% max. (Max. 8.3% finished surface slope)

CALC. BOOK NO. N/A SDR DATE 20-JULY-2020

OREGON STANDARD DRAWINGS
DETECTABLE WARNING SURFACE DETAILS

DATE 2021

The selection and use of this Standard Drawing, while designed in accordance with generally accepted engineering principles and practices, is the sole responsibility of the user and should not be used without consulting a Registered Professional Engineer.

Effective Date: December 1, 2020 – May 31, 2021 RD902

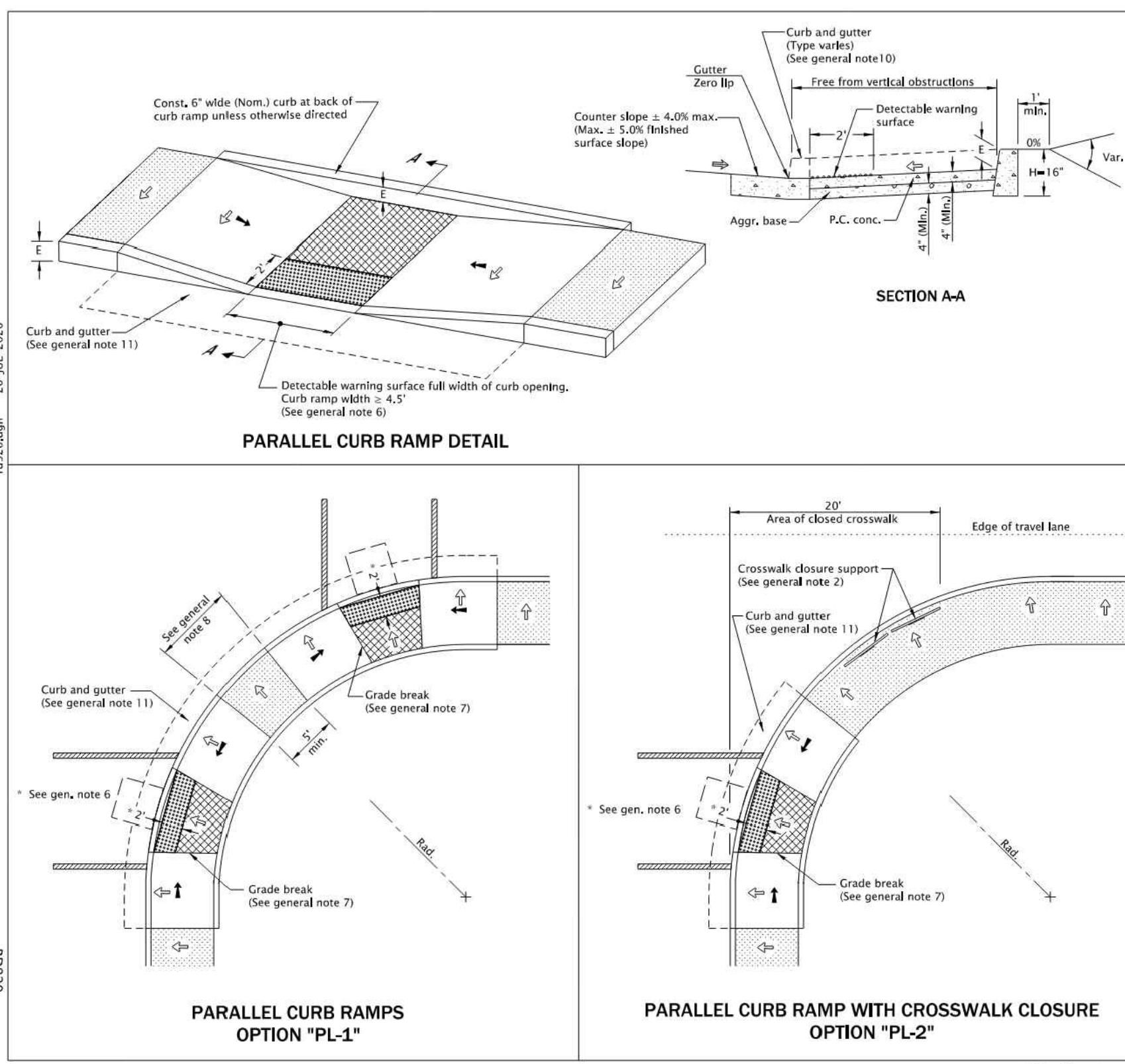
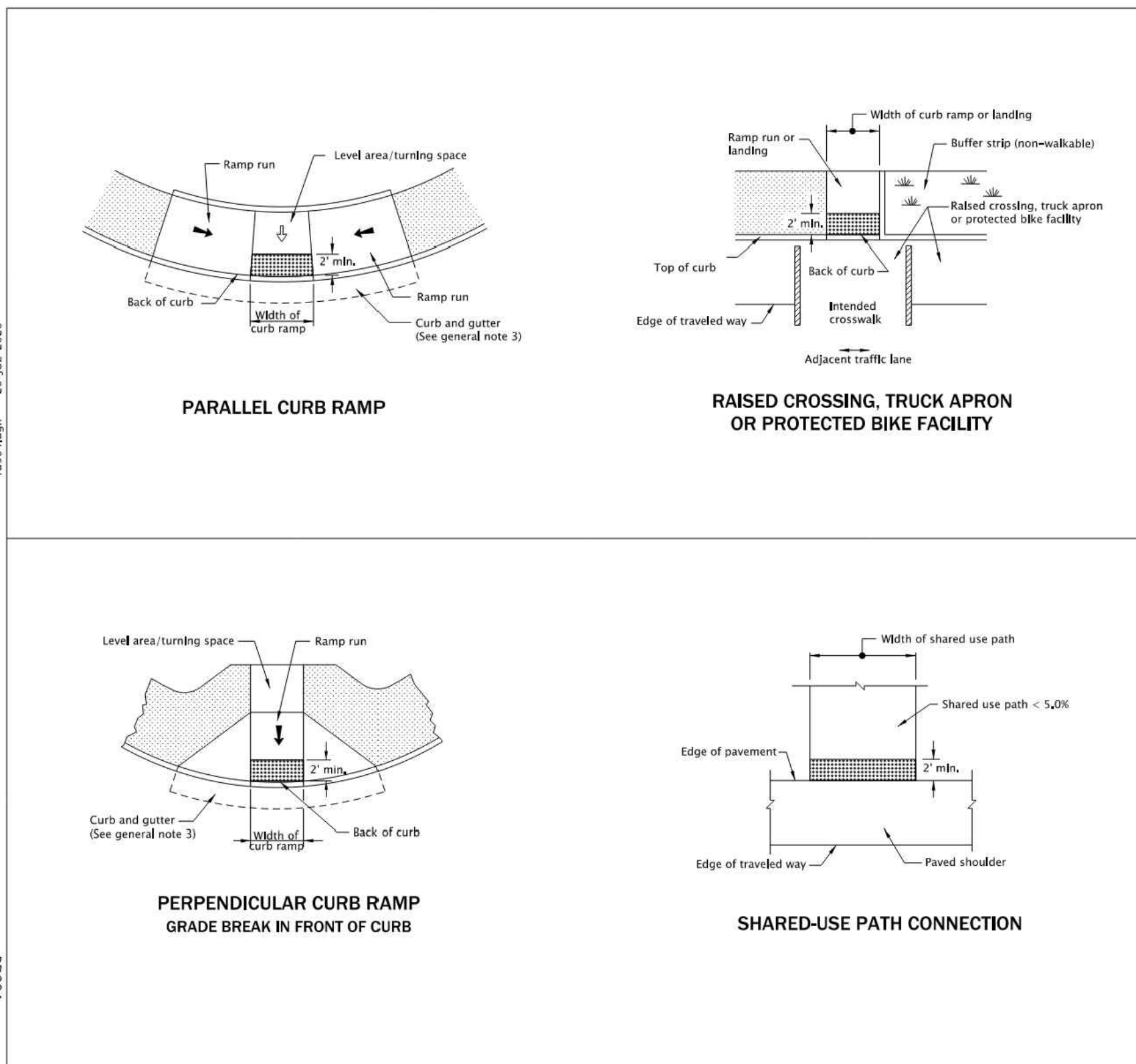

LEGENDS:

- Marked or Intended crossing location
- Sidewalk
- Detectable warning surface
- Cross slope 1.5% max. (Max. 2.0% finished surface slope) (Normal sidewalk cross slope)
- Running slope 7.5% max. (Max. 8.3% finished surface slope)

CALC. BOOK NO. N/A SDR DATE 20-JULY-2020

OREGON STANDARD DRAWINGS
DETECTABLE WARNING SURFACE PLACEMENT FOR CURB RAMP

DATE 2021

The selection and use of this Standard Drawing, while designed in accordance with generally accepted engineering principles and practices, is the sole responsibility of the user and should not be used without consulting a Registered Professional Engineer.

Effective Date: December 1, 2020 – May 31, 2021 RD904

LEGENDS:

- Sidewalk
- Detectable warning surface
- Level area (turning space/landing)
- Unobstructed 4.5' x 4.5' (longer dimension in direction of pedestrian street crossing).
- With obstruction 4.5' x 5.5' (longer dimension in direction of pedestrian street crossing).
- Cross slope 1.5% max. (Max. 2.0% finished surface slope) (Normal sidewalk cross slope)
- Running slope 7.5% max. (Max. 8.3% finished surface slope)
- Counter slope 4.0% max. ascending or descending. (Max. 5.0% finished surface slope) Slope as required for drainage.
- 4'x4' clear space

CALC. BOOK NO. N/A SDR DATE 20-JULY-2020

OREGON STANDARD DRAWINGS
PARALLEL CURB RAMP

DATE 2021

The selection and use of this Standard Drawing, while designed in accordance with generally accepted engineering principles and practices, is the sole responsibility of the user and should not be used without consulting a Registered Professional Engineer.

Effective Date: December 1, 2020 – May 31, 2021 RD920

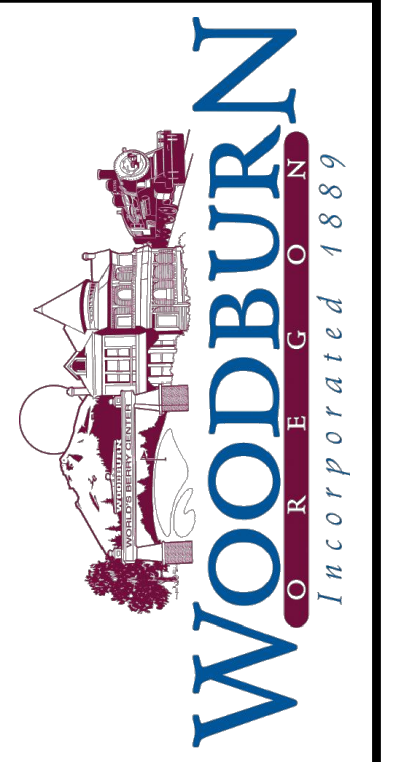
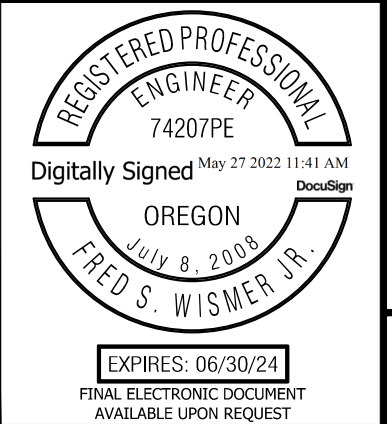

KITTELSON & ASSOCIATES
 851 SW 6TH AVENUE, SUITE 600
 PORTLAND, OR 97204
 P 503.228.5230 F 503.273.8169

NO.	DATE	REVISION
0	05/25/22	ISSUE FOR CONSTRUCTION
		FWW
		APPD

Submission Date: 03/07/2022
 Drawn: JCB/RMM Designed: NRS/JBK Checked: FSW
 PROJECT NO. 2015-001-20

W. Hayes Street Improvements
 Cascade Avenue to Settlemier Avenue

CURB RAMP DETAILS

SHEET NO. 2B-3

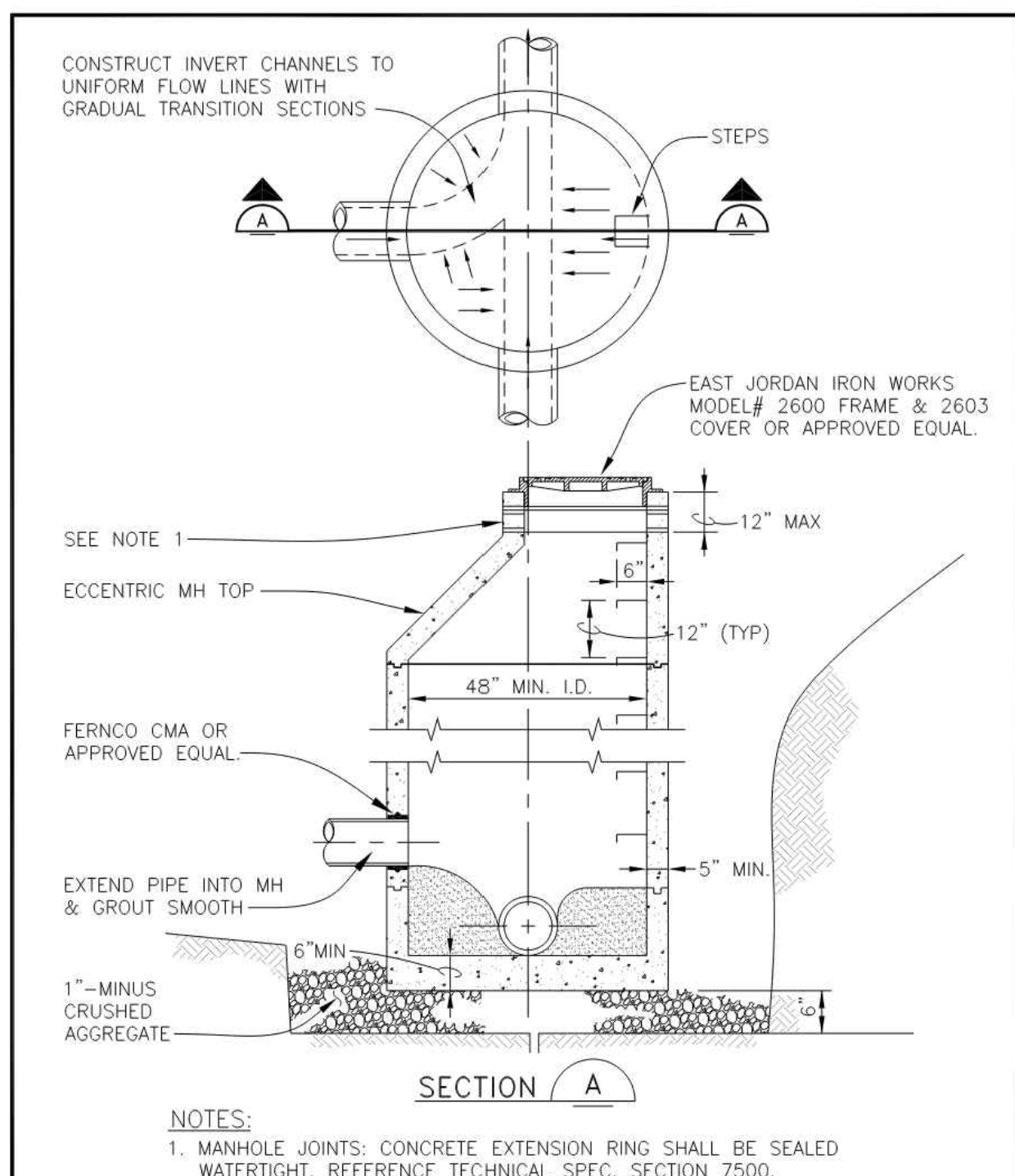
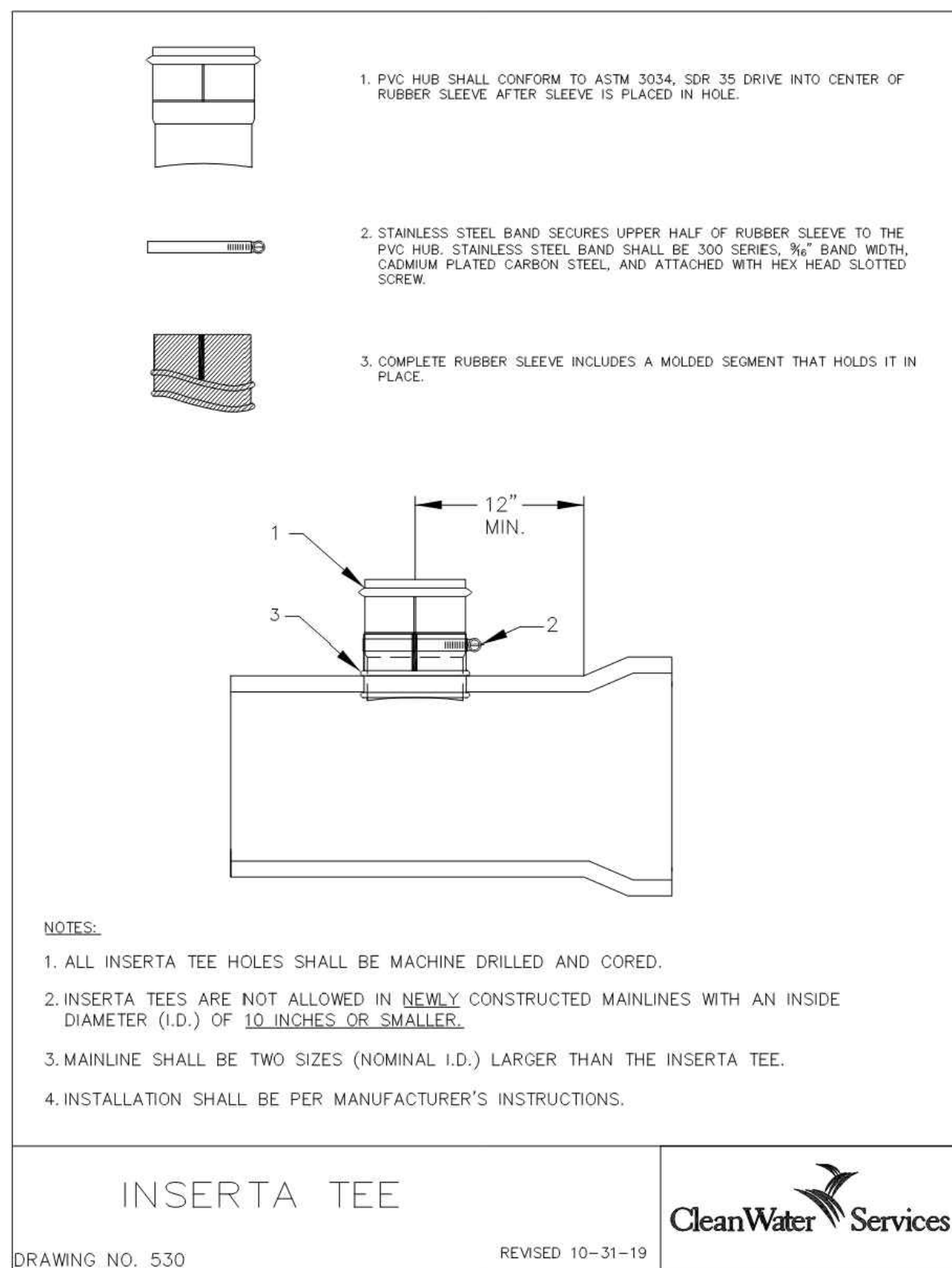

WOODBURN
Incorporated 1889
PUBLIC WORKS DEPARTMENT
ENGINEERING DIVISION

STORM SEWER MANHOLE

REV: DEC. 2007
SCALE: NTS
DET No. 7500-1

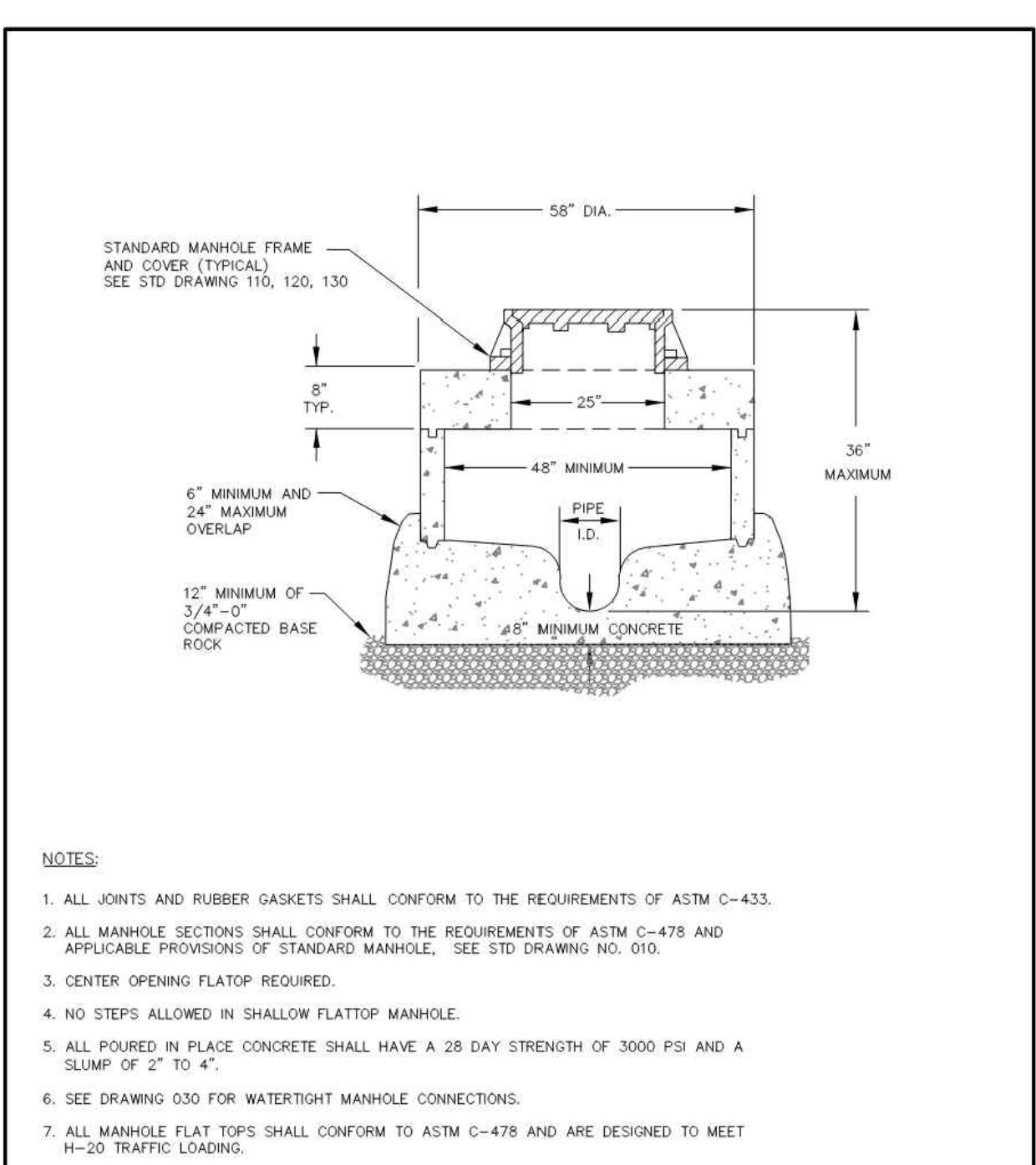

SHALLOW FLAT TOP MANHOLE

DRAWING NO. 040

REVISED 10-31-19

CleanWater Services

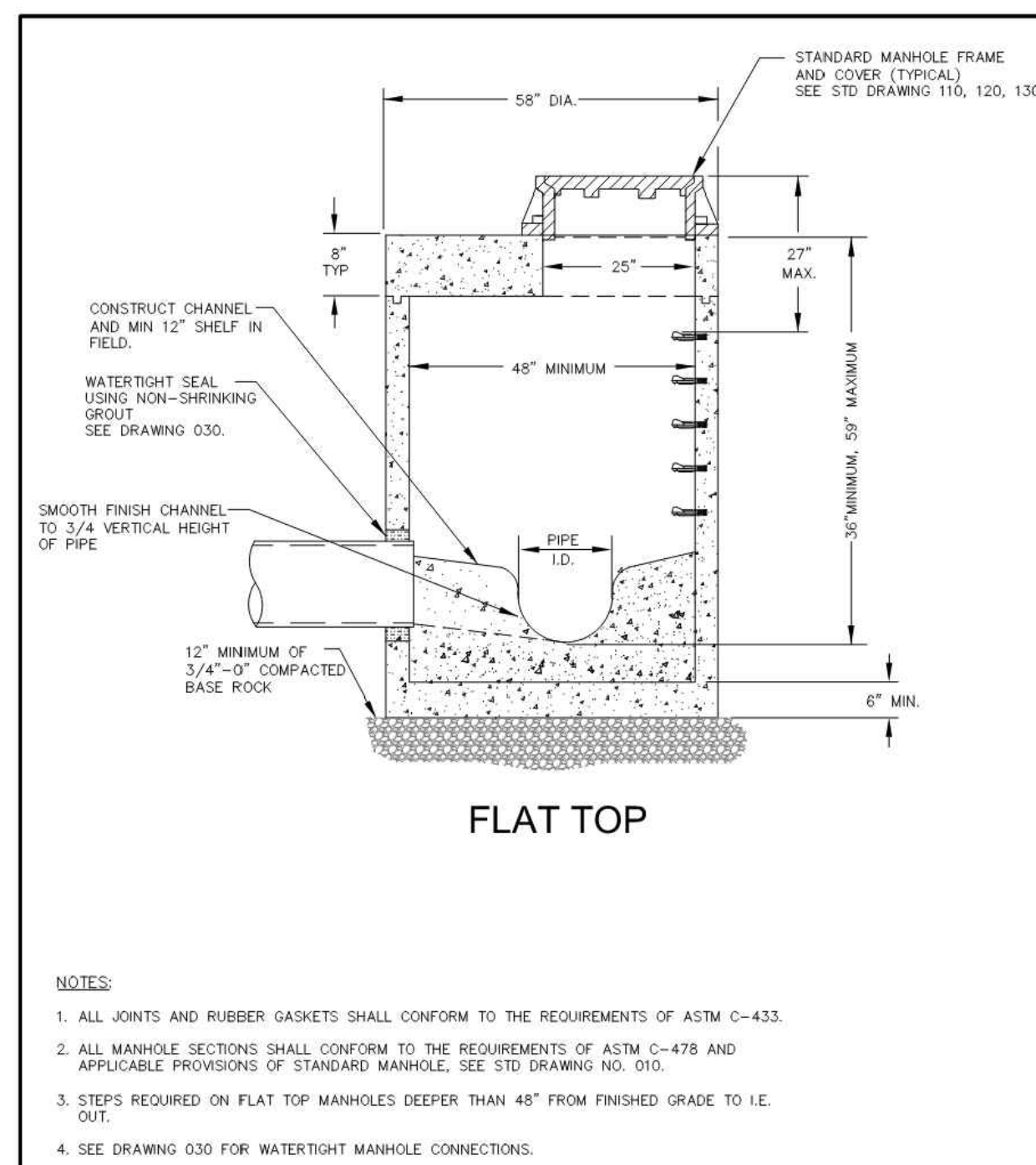

FLAT TOP MANHOLE

DRAWING NO. 050

REVISED 10-31-19

CleanWater Services

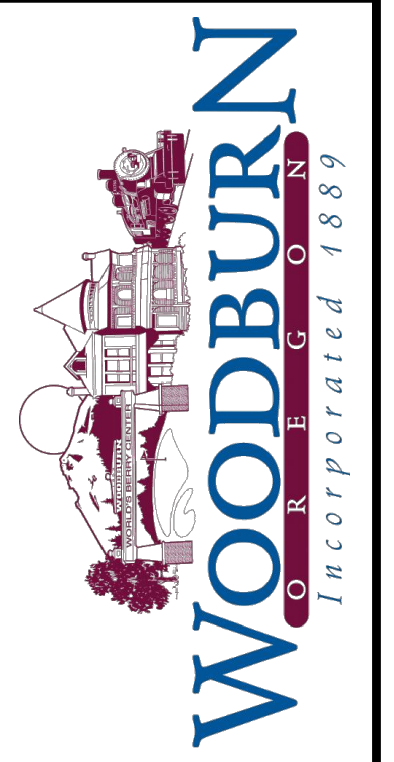
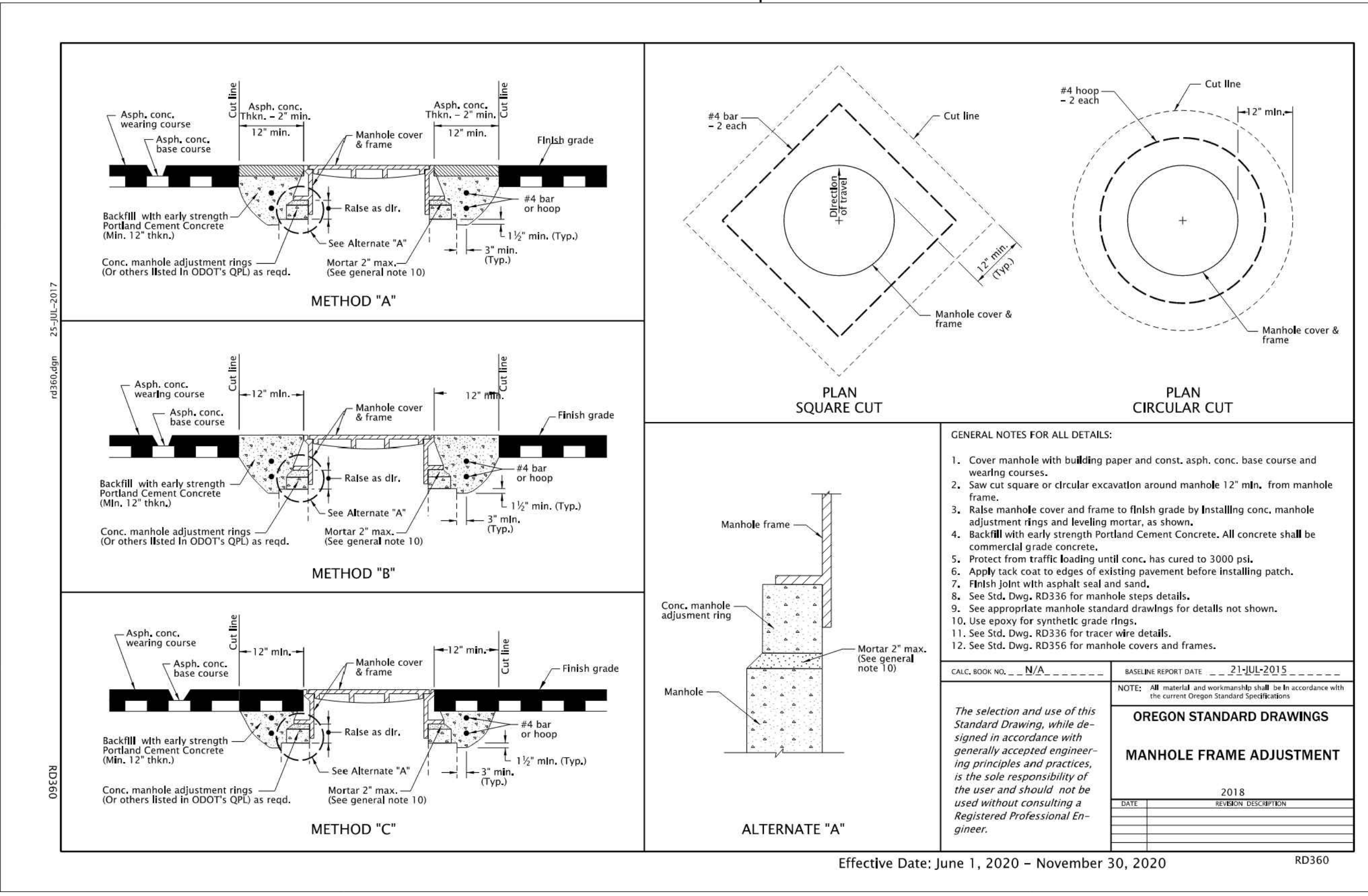

KITTELSON & ASSOCIATES

851 SW 6TH AVENUE, SUITE 600
PORTLAND, OR 97204
P 503.228.5230 F 503.273.8169

NO.	DATE	REVISION	APP'D
0	05/25/22	ISSUE FOR CONSTRUCTION	FSW

Submission Date: 03/07/2022

Drawn: JCB/RMM
Designed: NRS/JBK
Checked: FSW

PROJECT NO. 2015-001-20

W. Hayes Street Improvements
Cascade Avenue to Settlemier Avenue

STORM DETAILS

SHEET NO. 2B-4

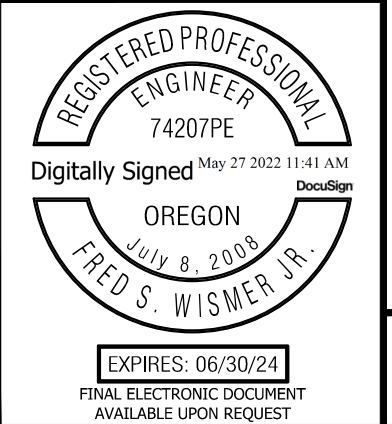

Plot Stamp: 5/25/2022 3:24:58 PM - Fred Wismer
File: H:\24\24512 - W. Hayes Street\design\CD\CD-Details-24512.dwg

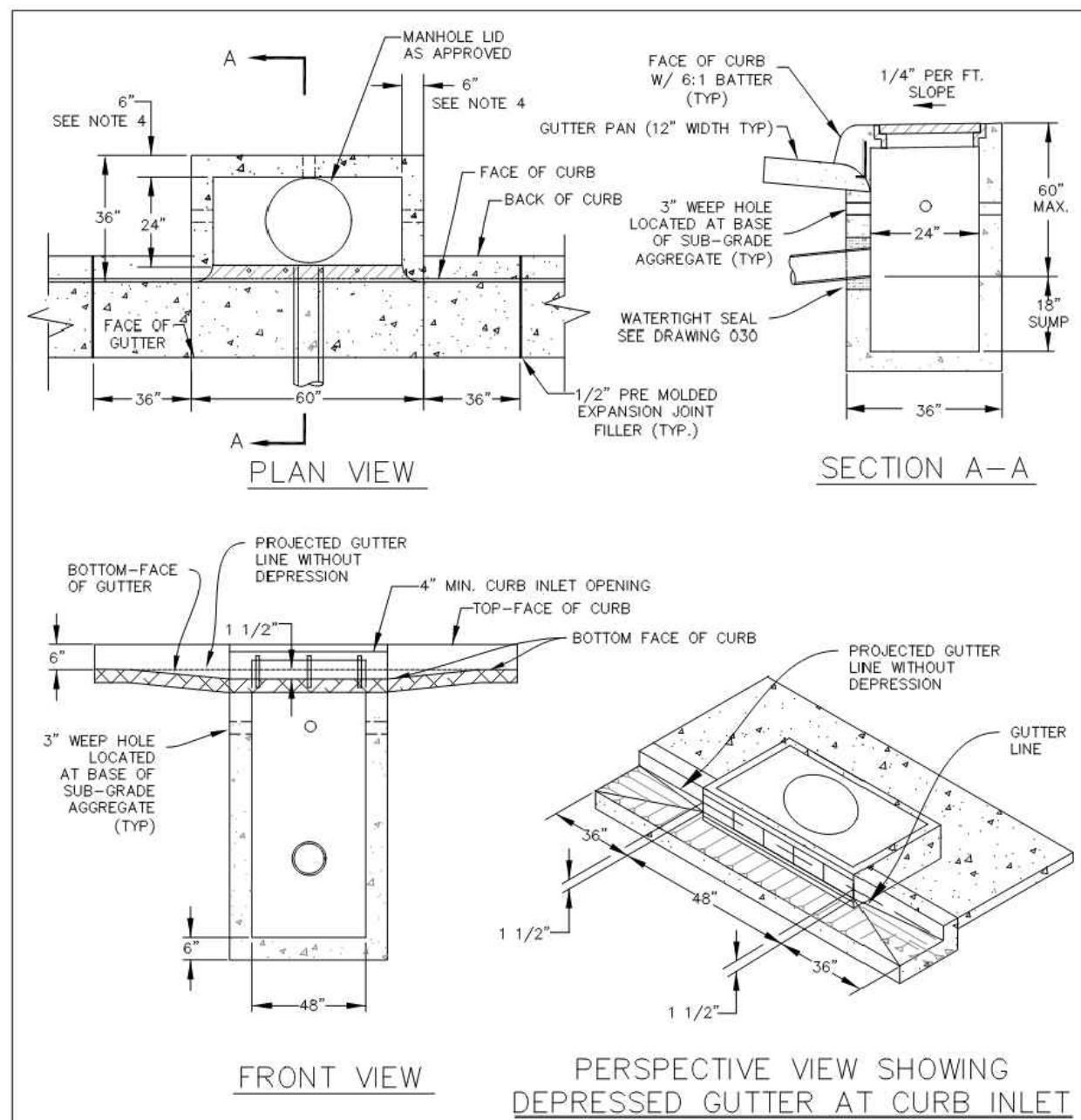

- NOTES:**
1. ALL POURED IN PLACE CONCRETE SHALL HAVE A 28 DAY STRENGTH OF 3000 P.S.I. AND A SLUMP OF 2" TO 4".
 2. INSTALL STRUCTURE ON MINIMUM OF 8" OF 3/4" - 0" COMPACTED BASE MATERIAL.
 3. NON-SUMP INLET CATCH BASINS SHALL BE CHANNELLED (E.G. FLOW THROUGH CBS).
 4. WALL THICKNESS SHALL BE 6" MIN. TO 10" MAX. FOR POURED IN PLACE STRUCTURES.
 5. PRECAST STRUCTURE TO BE APPROVED BY DISTRICT OR CITY. REINFORCEMENT FOR PRECAST CATCH BASIN SHALL BE REBAR MEETING ASTM A-615, GRADE 60 OR WELDED WIRE MEETING ASTM A-497.

INLET CATCH BASIN (CG-48)

DRAWING NO. 340 REVISED 10-31-19

CleanWater Services

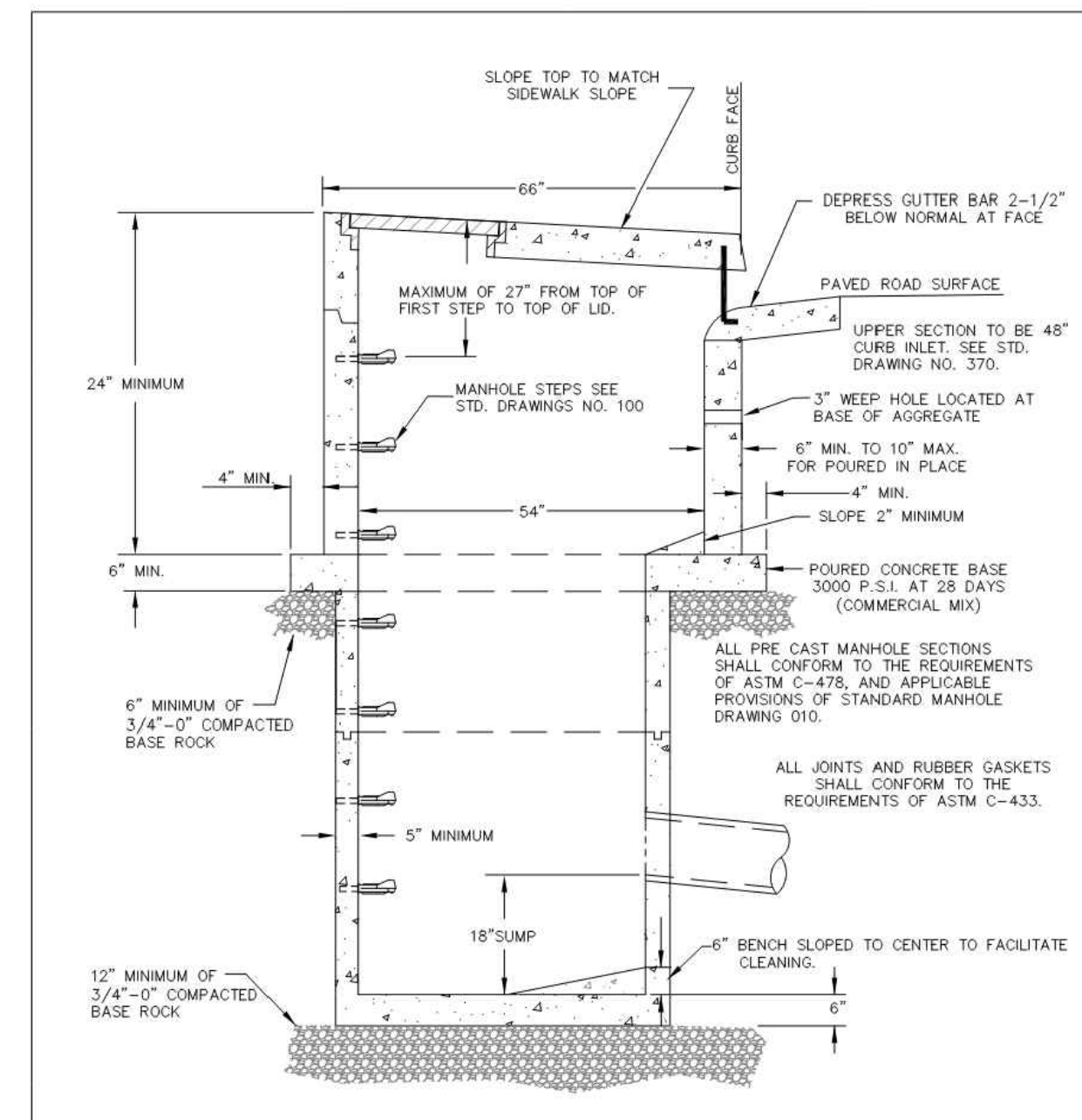

- NOTES:**
1. NON-SUMP INLET MANHOLE SHALL BE CHANNELLED.
 2. SEE STD. DRAWING 370 FOR TOP SECTION DETAILS.

APPROVED FOR USE BY WASHINGTON COUNTY ONLY.

MODIFIED CURB INLET MANHOLE (MOD.CG-48MH)

DRAWING NO. 360 REVISED 10-31-19

CleanWater Services

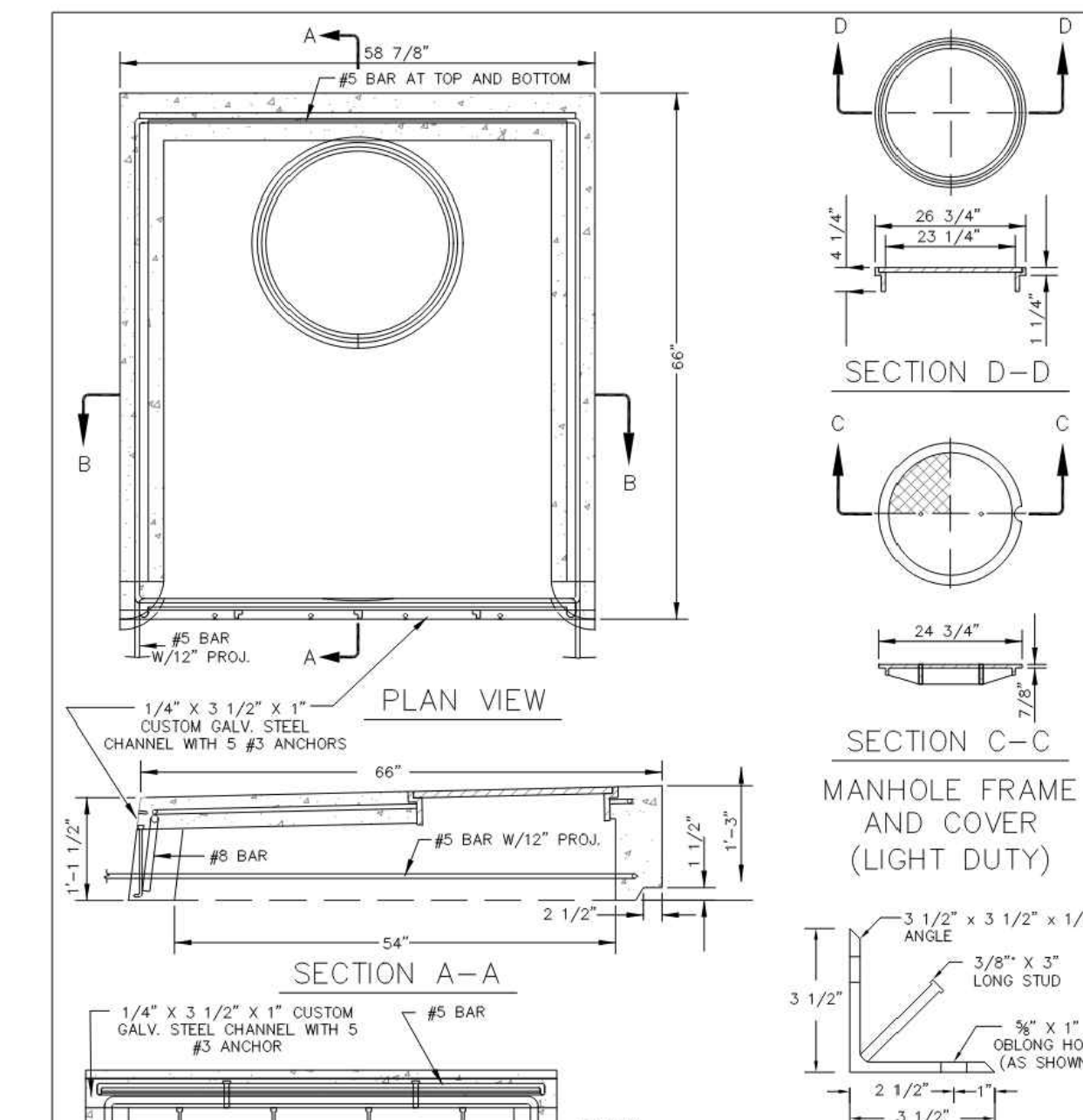

- NOTES:**
1. MATERIAL SHALL BE NEW STRUCTURAL ASTM A-36 STEEL.

TOP-CURB INLET MANHOLE AND MODIFIED CURB INLET MANHOLE (CG-48 M.H. AND MOD. CG-48 M.H.)

DRAWING NO. 370 REVISED 10-31-19

CleanWater Services

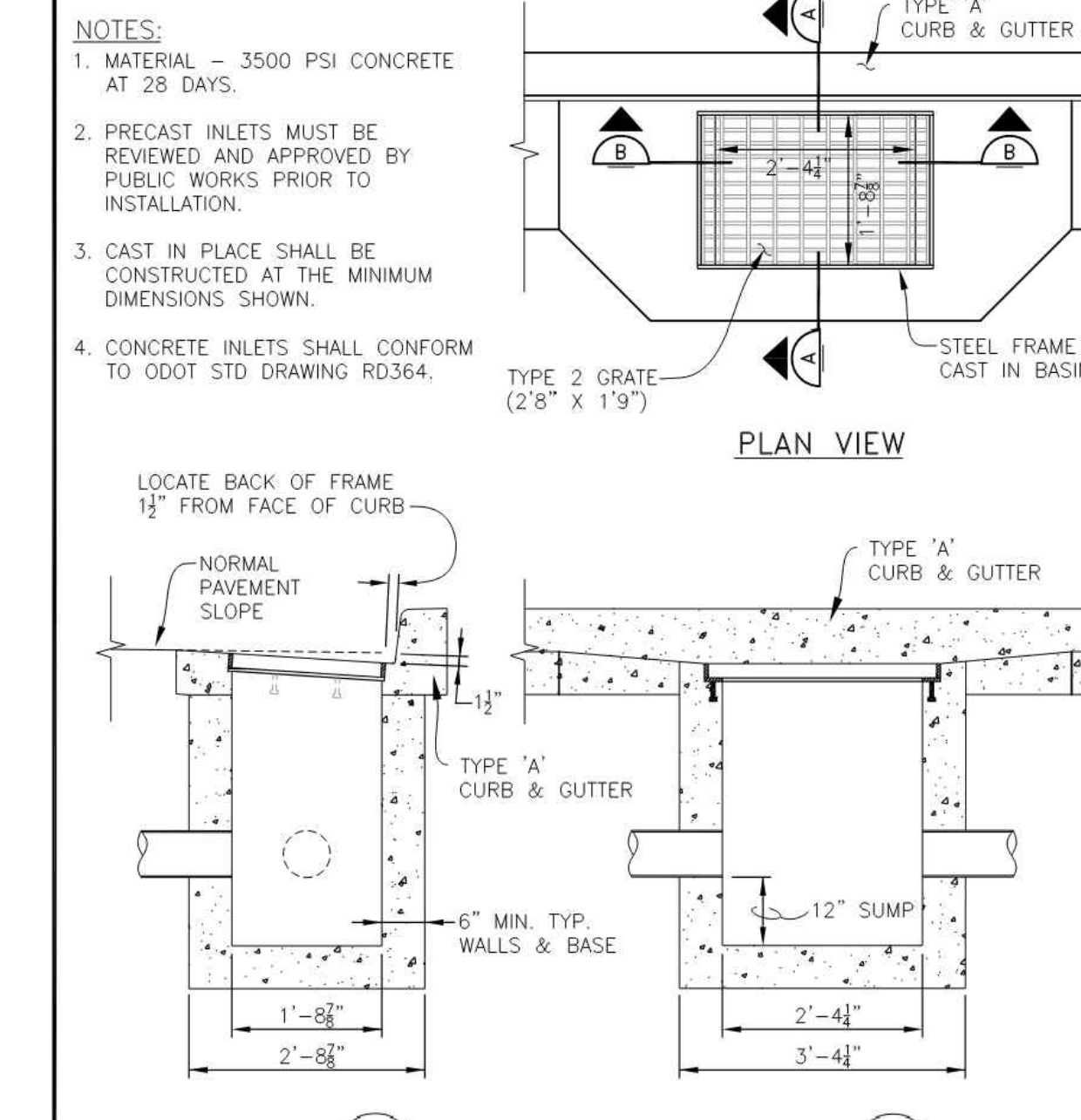

- NOTES:**
1. MATERIAL - 3500 PSI CONCRETE AT 28 DAYS.
 2. PRECAST INLETS MUST BE REVIEWED AND APPROVED BY PUBLIC WORKS PRIOR TO INSTALLATION.
 3. CAST IN PLACE SHALL BE CONSTRUCTED AT THE MINIMUM DIMENSIONS SHOWN.
 4. CONCRETE INLETS SHALL CONFORM TO ODOT STD DRAWING RD364.

WOODBURN ENGINEERS

INLET

REV: AUG. 2009
SCALE: NTS
DET No. 7100-4

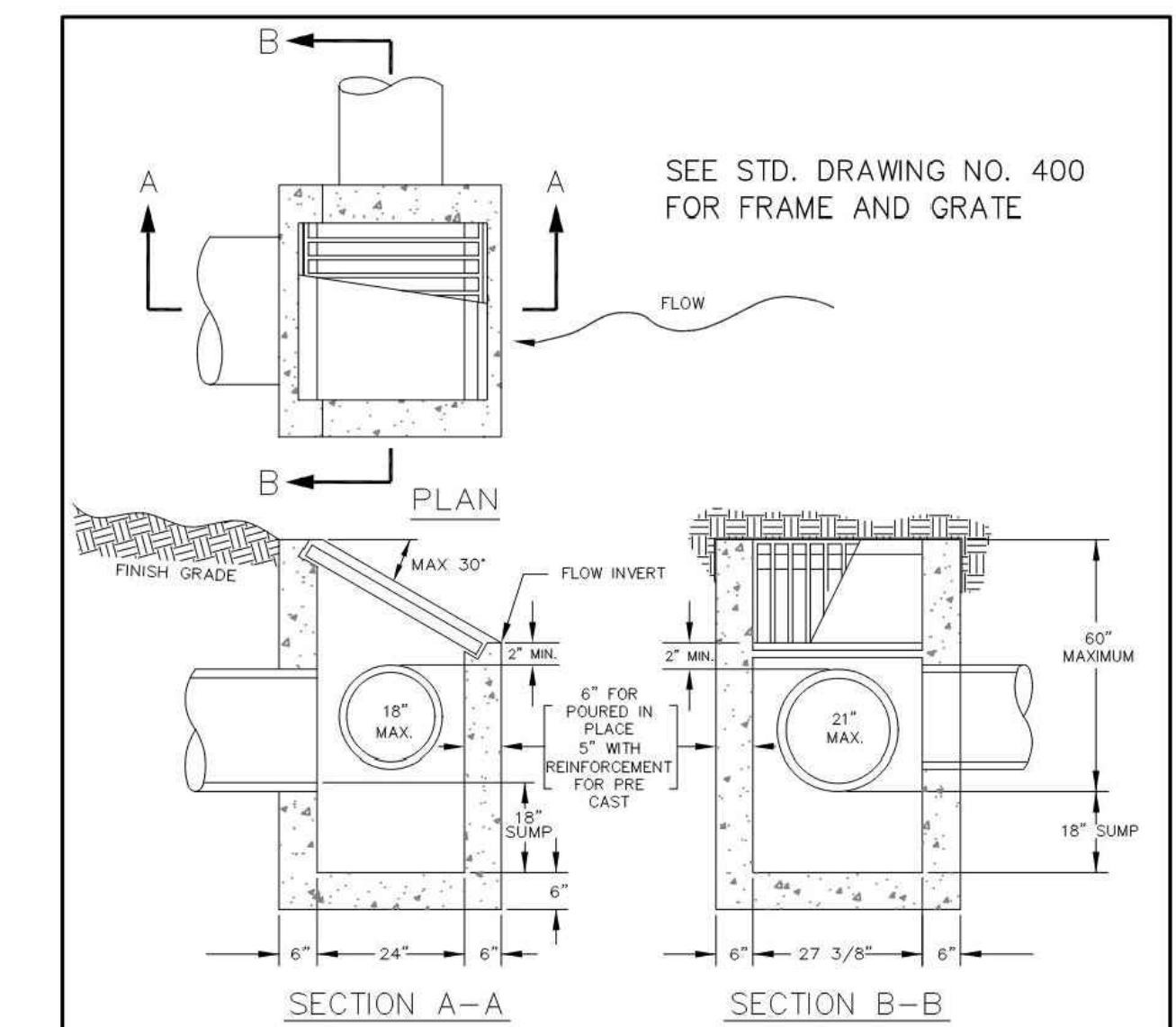

- NOTES:**
1. ALL PRE CAST SECTIONS SHALL CONFORM TO REQUIREMENTS OF ASTM C-478.
 2. INSTALL STRUCTURE ON MINIMUM OF 8" OF 3/4" - 0" COMPACTED BASE MATERIAL. PRE CAST REINFORCEMENT SHALL BE REBAR MEETING ASTM A615 GRADE 60 OR WELDED WIRE MEETING ASTM A497.
 3. ALL POURED IN PLACE CONCRETE SHALL HAVE A 28 DAY STRENGTH OF 3000 PSI AND SLUMP OF 2" TO 4".
 4. PRE-CAST STRUCTURE'S CONFORMING TO O.D.O.T. TYPE G-2 CATCH BASIN DESIGN WITH DITCH INLET TOP ARE AN ACCEPTABLE ALTERNATE. ALL GRATE MATERIALS SHALL MEET C.W.S. STANDARDS AS SHOWN ON DETAIL #400.

DITCH INLET

DRAWING NO. 390 REVISED 10-31-19

CleanWater Services

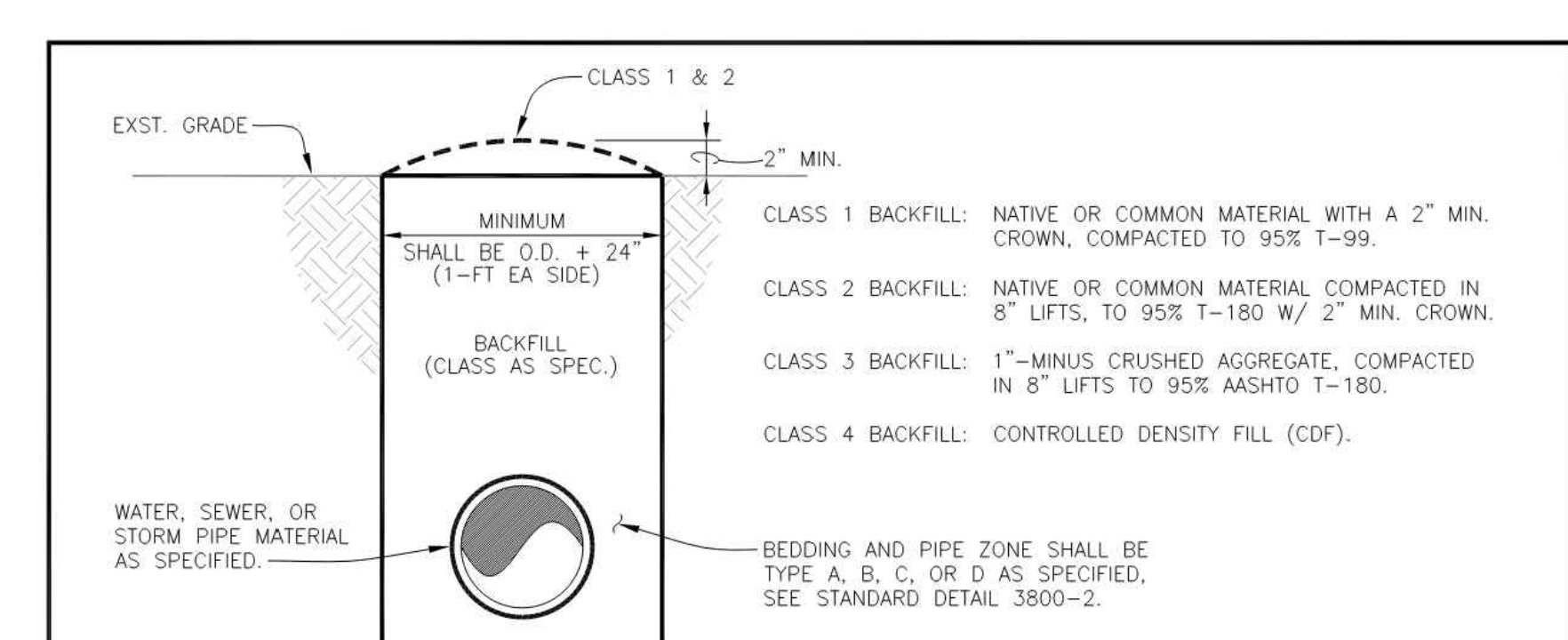

- NOTES:**
1. ENGINEER WILL CONSIDER ADJUSTING USUAL TRENCH WIDTH TO ACCOMMODATE CONDITION ENCOUNTERED.
 2. REFERENCE TECHNICAL SPEC. SECTION 3800.
 3. FOR HMA TRENCH CAP SURFACE REPLACEMENT SEE DETAIL 3800-5.

WOODBURN ENGINEERS

PIPE TRENCH BACKFILL

REV: DEC. 2007
SCALE: NTS
DET No. 3800-1

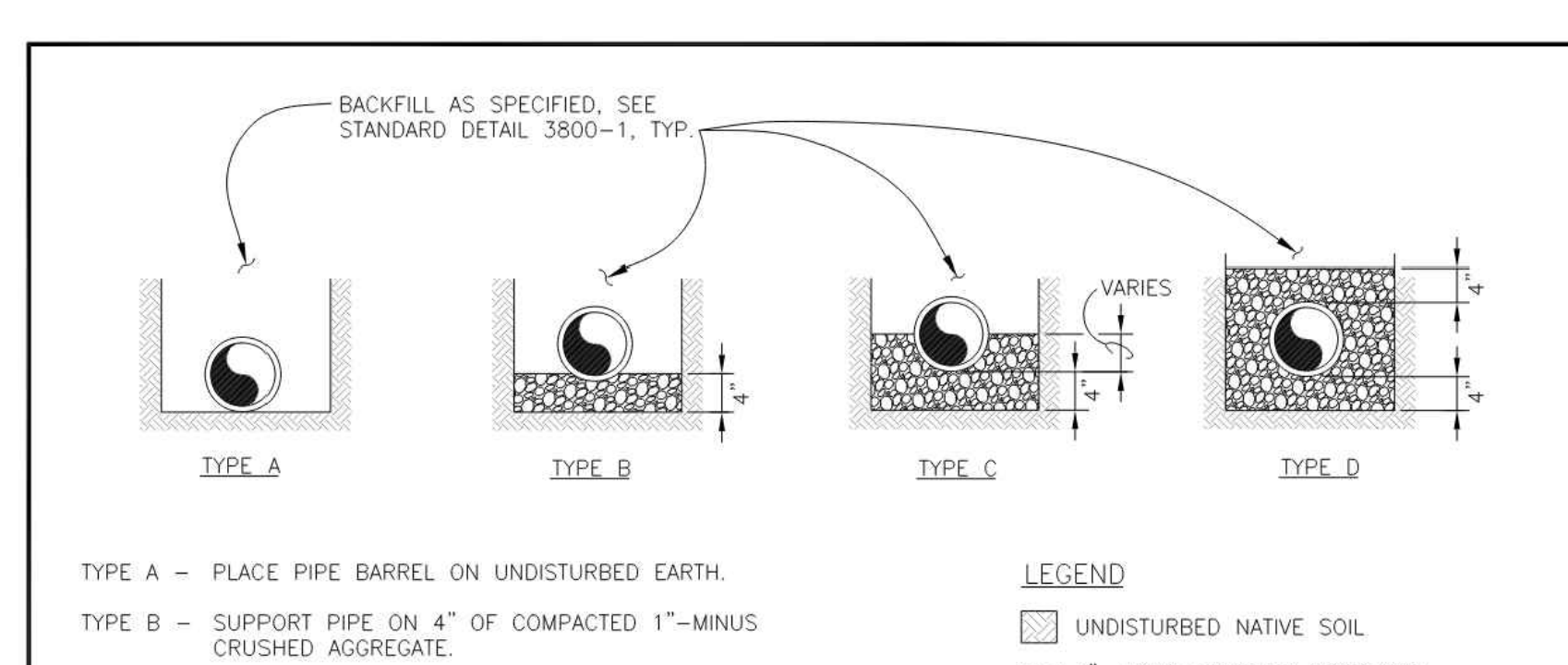

- NOTES:**
1. REFERENCE TECHNICAL SPEC. SECTION 3800.

WOODBURN ENGINEERS

PIPE TRENCH BEDDING AND ZONE

REV: DEC. 2007
SCALE: NTS
DET No. 3800-2

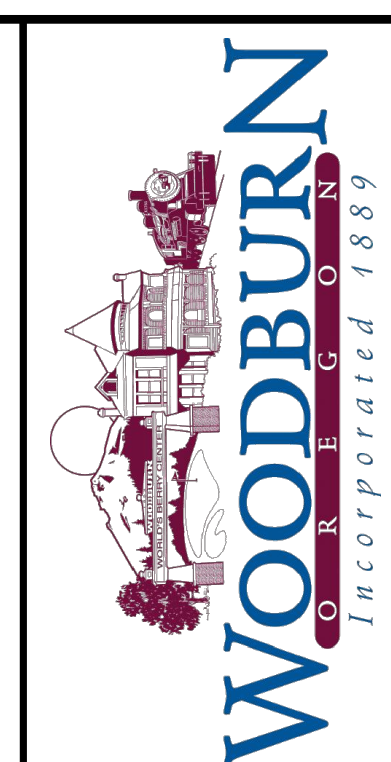

KITTELSON & ASSOCIATES

851 SW 6TH AVENUE, SUITE 600
PORTLAND, OR 97204
P 503.228.5230 F 503.273.8169

REV.	DATE	DESCRIPTION	APP'D.
0	05/25/22	ISSUE FOR CONSTRUCTION	FSW
		REVISION	

Submission Date: 03/07/2022

Drawn: JCB/RMM
Designed: NRS/JBK
Checked: FSW

PROJECT NO. 2015-001-20

W. Hayes Street Improvements
Cascade Avenue to Settlemier Avenue

STORM DETAILS

SHEET NO. 2B-5

Plot Stamp: 5/25/2022 3:25:01 PM - Fred Wismer
File: H:\24\24512 - W. Hayes Street\design\CD\CD-Details-24512.dwg

BROOKS PRODUCTS		
COVER	MODEL NO.	METER BOX
1"	No. 37-T CAST IRON COVER*	No. 37 MB-BODY*
2"	No. 65-TF STEEL COVER (FLUSH)*	No. 65 MB-BODY*

* OR APPROVED EQUAL

WOODBURN
Incorporated 1889
PUBLIC WORKS DEPARTMENT
ENGINEERING DIVISION

METER BOX

REV:	FEB. 2020
SCALE:	NTS
DET No.	5050-1

VALVE BOX COVER SHALL BE EAST JORDAN IRON WORKS MODEL# 3639A1 OR APPROVED EQUAL.

ADJUST TO FINISH GRADE

FINISH GRADE

18" VALVE BOX TOP SECTION SHALL BE EAST JORDAN IRON WORKS MODEL# 3639Z1 18" OR APPROVED EQUAL.

3" MIN.

6" MIN.

SLIDE VALVE BOX BOTTOM SECTION SHALL BE 6-INCH DIAMETER, SDR 35 PIPE OR APPROVED EQUAL.

D.I. WATER MAIN

M.J. OR FLANGED VALVE

CONCRETE PIER BLOCK POUR ON UNDISTURBED EARTH, MIN. AREA OF 2 SQ. FT. VALVE TO HAVE TEMPORARY BLOCKING DURING CURE.

NOTES:
1. REFERENCE TECHNICAL SPEC. SECTION 5050.

WOODBURN
Incorporated 1889
PUBLIC WORKS DEPARTMENT
ENGINEERING DIVISION

VALVE ASSEMBLY

REV:	FEB. 2020
SCALE:	NTS
DET No.	5050-2

NOTES:
1. BED PIPE WITH 1"-MINUS SO AS TO CARRY LOAD OF PIPE EVENLY WITHOUT FIXING LOAD ON PIER BLOCKS DIG OUT BELOW BED FOR PIER BLOCKS, AS DIRECTED.
2. BURY HEIGHT: 3-1/2 TO 4 FEET. IF GREATER DEPTH IS REQUIRED EXTENSIONS SHALL BE USED TO ADJUST FH TO PROPER HEIGHT.
3. BACK FILL SHALL BE OF TYPE SPECIFIED.
4. D.I. PIPE BETWEEN VALVE AND FH SHALL BE BY MEANS OF MECHANICAL JOINT WITH MEGALUG PIPE CONNECTORS OR COATED THREADED TIE RODS, AS APPROVED.

HYDRANT: MUELLER CENTURION A423 OR M & H RELIANT 929T. REFERENCE TECHNICAL SPEC. SECTION 5070.

18" MIN. 24" MAX.

BREAKAWAY FLANGE

FINISH GRADE

BACK FILL, SEE NOTE 3

VALVE BOX, SEE DET. 5050-2

6" M.J. x FLANGED GATE VALVE

SEE NOTE 2

M.J. HYDRANT W/ MEGALUG

M.J. VALVE WITH MEGALUG

6" D.I. PIPE

TEE M.J. x FLANGED

THRUST BLOCK

PIER BLOCKS

CONCRETE THRUST BLOCK SEE DETAILS 5000-1 & 2

PIPE ZONE TO BE TYPE 'D' AS SHOWN IN STANDARD DETAIL 3800-2.

WOODBURN
Incorporated 1889
PUBLIC WORKS DEPARTMENT
ENGINEERING DIVISION

FIRE HYDRANT ASSEMBLY

REV:	FEB. 2020
SCALE:	NTS
DET No.	5070-1

FORD CO. MODEL	
CORP STOP	ANGLE METER VALVE
DIA.	Model No.
1"	F1000-4* KV43-444W*
1.5"	FB1000-4* FB1000-4* FV43-666W*
2"	FB500-7* FB500-7* FV43-777W*

* OR APPROVED EQUAL

CURB AND GUTTER

STREET

5' SIDEWALK

PROPERTY LINE RIGHT-OF-WAY

UTILITY EASEMENT

18" MIN.

2"

METER BOX SEE DETAIL 5050-1

WATER METER SEE NOTE 1

FOR ANGLE METER VALVE SEE TABLE ABOVE.

TYPE "K" COPPER TUBING

FOR CORPORATION STOP SEE TABLE ABOVE. SET TAP AT 45° IN DIRECTION OF METER.

D.I. WATER MAIN, TYP.

36" NORMAL COVER

30"

45°

NOTES:
1. WATER METER AND TAILPIECE SHALL BE FURNISHED AND INSTALLED BY CITY WATER DIVISION.
2. WATER DIVISION SHALL HAVE SOLE RESPONSIBILITY FOR TAPPING LIVE MAINS.
3. REFERENCE TECHNICAL SPEC. SECTION 5000.
4. 1.5" & 2" SERVICE LINES SHALL BE SADDLE TAPPED WITH BRONZE DOUBLE STRAPS.

WOODBURN
Incorporated 1889
PUBLIC WORKS DEPARTMENT
ENGINEERING DIVISION

WATER SERVICE CONNECTION

REV:	MAY 2011
SCALE:	NTS
DET No.	5000-4

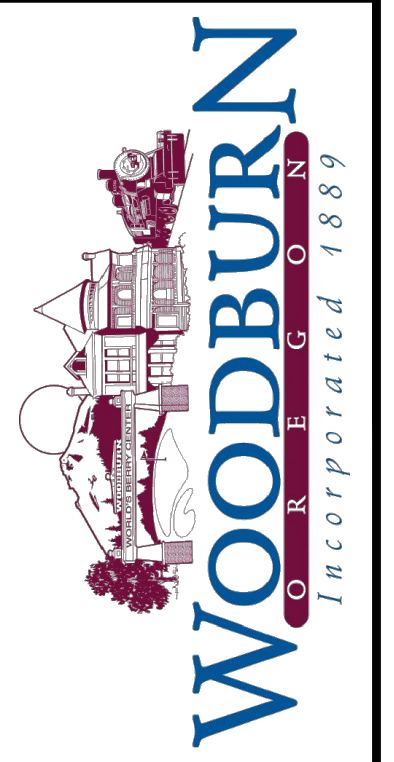
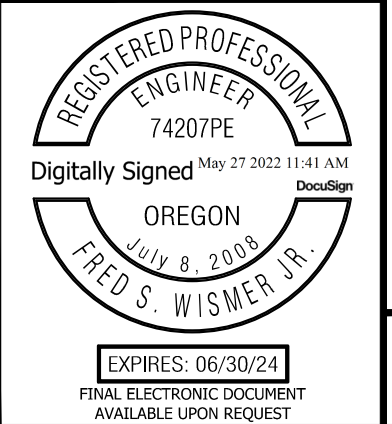

KITTELSON & ASSOCIATES

851 SW 6TH AVENUE, SUITE 600
PORTLAND, OR 97204
P 503.228.5230 F 503.273.8169

DATE	REVISION	APP'D
01/05/25/22	ISSUE FOR CONSTRUCTION	FSW

Submission Date: 03/07/2022

Drawn: JCB/RMM Designed: NRS/JBK Checked: FSW

PROJECT NO. 2015-001-20

W. Hayes Street Improvements
Cascade Avenue to Settlemier Avenue

WATER DETAILS

SHEET NO. 2B-6

Plot Stamp: 5/25/2022 3:25:05 PM - Fred Wismer
 File: H:\24\24512 - W. Hayes Street\design\CD\CD-Traffic-Control-Plans-Detours-24512.dwg

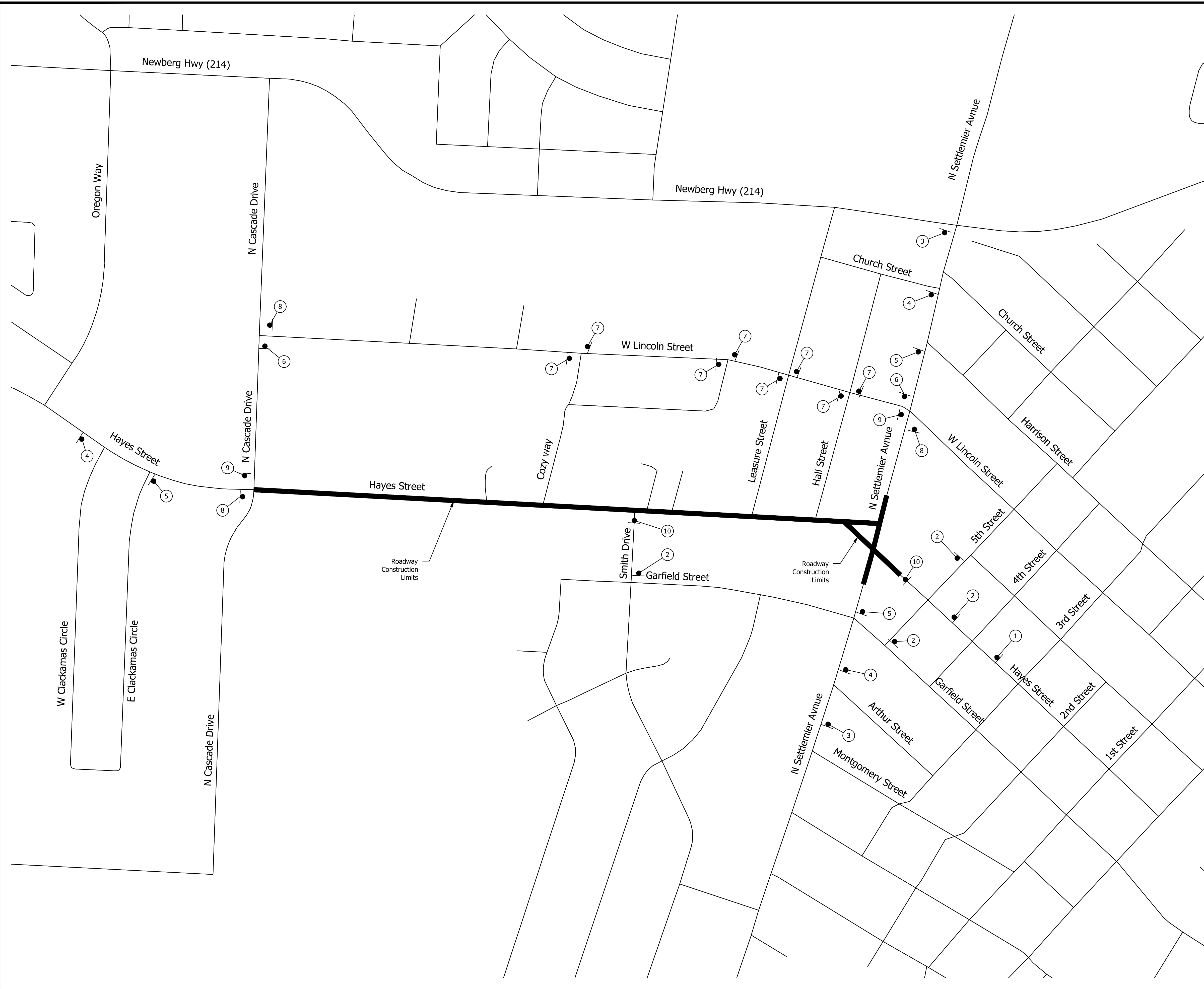

- GENERAL TRAFFIC CONTROL NOTES**
1. ALL SIGNS ARE TYPE "O4" UNLESS OTHERWISE NOTED ON PLANS.
 2. PLACE TEMPORARY SIGN SUPPORT (TSS) APPROXIMATELY 10' BEHIND BARRICADE.
 3. MAINTAIN ALL EXISTING REGULATORY AND WARNING SIGNS IN WORK AREA ON TEMPORARY SIGN SUPPORT (TSS) AS DIRECTED BY THE ENGINEER.
 4. ALL TRAFFIC CONTROL IS TO BE IN ACCORDANCE WITH THE CURRENT MUTCD (MANUAL ON UNIFORM TRAFFIC CONTROL DEVICES).
 5. NIGHT WORK NOT ALLOWED.
 7. CONTRACTOR TO MAINTAIN DRIVEWAY ACCESSES.
 8. CONTRACTOR TO USE ABRUPT EDGE DETAIL ODOT STANDARD DRAWING TM800 FOR SHOULDER DROP OFF.
 9. SEE 2C-3 THRU 2C-7 FOR PROJECT LEVEL CONSTRUCTION LIMITS AND ADDITIONAL TRAFFIC CONTROL SIGNS REQUIRED.

TRAFFIC CONTROL SIGN LEGEND

1	ROAD CLOSED 500 FT W20-3 36" x 36" Hayes Street 42" x 18"	2	ROAD CLOSED 250 FT W20-3 36" x 36" Hayes Street 42" x 18"
3	ROAD CLOSED 750 FT W20-3 36" x 36" Hayes Street 42" x 18" DETOUR AHEAD M4-8 24x12	4	ROAD CLOSED 500 FT W20-3 36" x 36" Hayes Street 42" x 18" DETOUR AHEAD M4-8 24x12
5	ROAD CLOSED 250 FT W20-3 36" x 36" Hayes Street 42" x 18" DETOUR AHEAD M4-8 24x12	6	Hayes Street 42" x 18" DETOUR M4-9R 30" x 24"
7	Hayes Street 42" x 18" DETOUR M4-9S 30" x 24"	8	Hayes Street 42" x 18" DETOUR M4-9L 30" x 24"
9	Hayes Street 42" x 18" END DETOUR M4-8a 24" x 18"	10	R11-4 60" x 30"

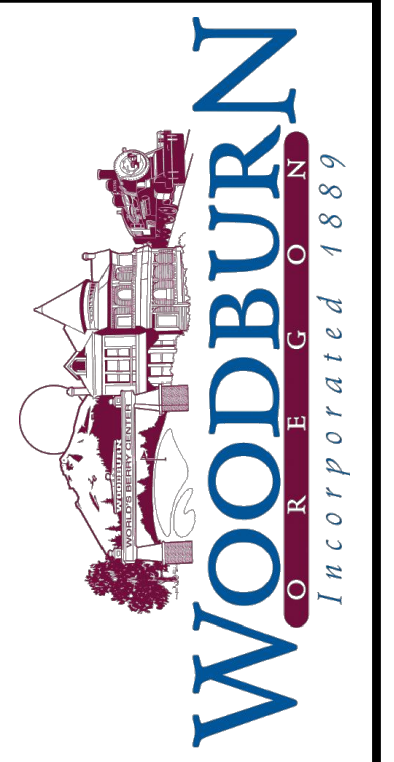
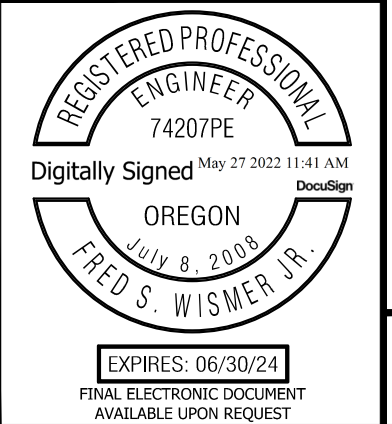
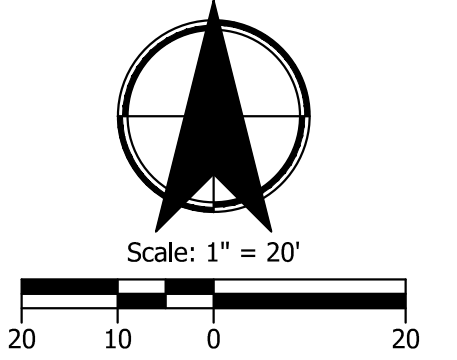

KITTELSON & ASSOCIATES
 851 SW 6TH AVENUE, SUITE 600
 PORTLAND, OR 97204
 P 503.228.5230 F 503.273.8169

NO.	DATE	REVISION
0	05/25/22	ISSUE FOR CONSTRUCTION
		FSW
		APP'D

Submission Date: 03/07/2022
 Drawn: JCB/RMM
 Designed: NRS/JBK
 Checked: FSW

PROJECT NO. 2015-001-20
W. Hayes Street Improvements
 Cascade Avenue to Settlemier Avenue
 TRAFFIC CONTROL DETOUR PLAN
 SHEET NO. 2C

#	DATE	REVISION	APP'D
0	05/25/22	ISSUE FOR CONSTRUCTION	FSW

Submission Date: 03/07/2022

Drawn: JCB/RMM Designed: NRS/JBK Checked: FSW

PROJECT NO. 2015-001-20

W. Hayes Street Improvements
Cascade Avenue to Settlemier Avenue







TRAFFIC CONTROL PLANS - STAGE 1

SHEET NO. 2C-2

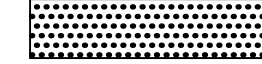
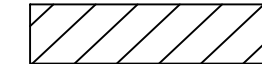
GENERAL NOTES

1. ALL SIGNS ARE TYPE "O4" UNLESS OTHERWISE NOTED ON PLANS.
2. PLACE TEMPORARY SIGN SUPPORT (TSS) APPROXIMATELY 10' BEHIND BARRICADE.
3. MAINTAIN ALL EXISTING REGULATORY AND WARNING SIGNS IN WORK AREA ON TEMPORARY SIGN SUPPORT (TSS) AS DIRECTED BY THE ENGINEER.
4. ALL TRAFFIC CONTROL IS TO BE IN ACCORDANCE WITH THE CURRENT MUTCD (MANUAL ON UNIFORM TRAFFIC CONTROL DEVICES).
5. NIGHT WORK NOT ALLOWED.
6. REMOVE EXISTING CONFLICTING STRIPING AND MARKERS.
7. CONTRACTOR TO MAINTAIN DRIVEWAY ACCESSES.
8. CONTRACTOR TO USE ABRUPT EDGE DETAIL ODOT STANDARD DRAWING TM800 FOR SHOULDER DROP OFF.
9. STAGE SIDEWALK CONSTRUCTION TO BE ONE SIDE OF THE STREET AT A TIME.

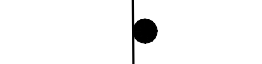
LEGEND

-  UNDER TRAFFIC
-  UNDER CONSTRUCTION
-  28" TUBULAR MARKERS WITH 20' SPACING & 10' SPACING ON TANGENTS, TAPERS AND RADII
-  TYPE III BARRICADE
-  TSS SIGN SUPPORT AS SHOWN ON ODOT STANDARD DRG. TM821
-  PORTABLE SIGN SUPPORT
-  POST MOUNTED CONSTRUCTION SIGN
-  DIRECTION OF TRAFFIC (ARROWS SHOWN FOR ILLUSTRATIVE PURPOSES ONLY)

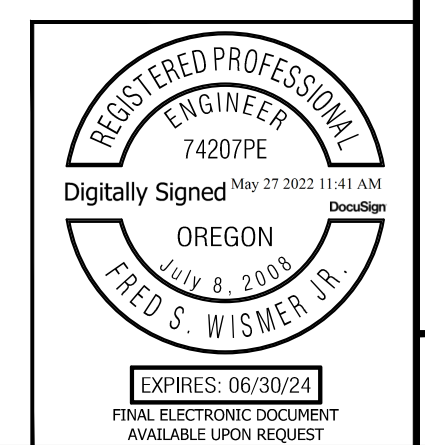
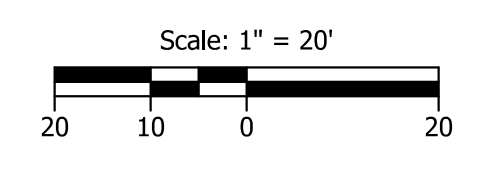
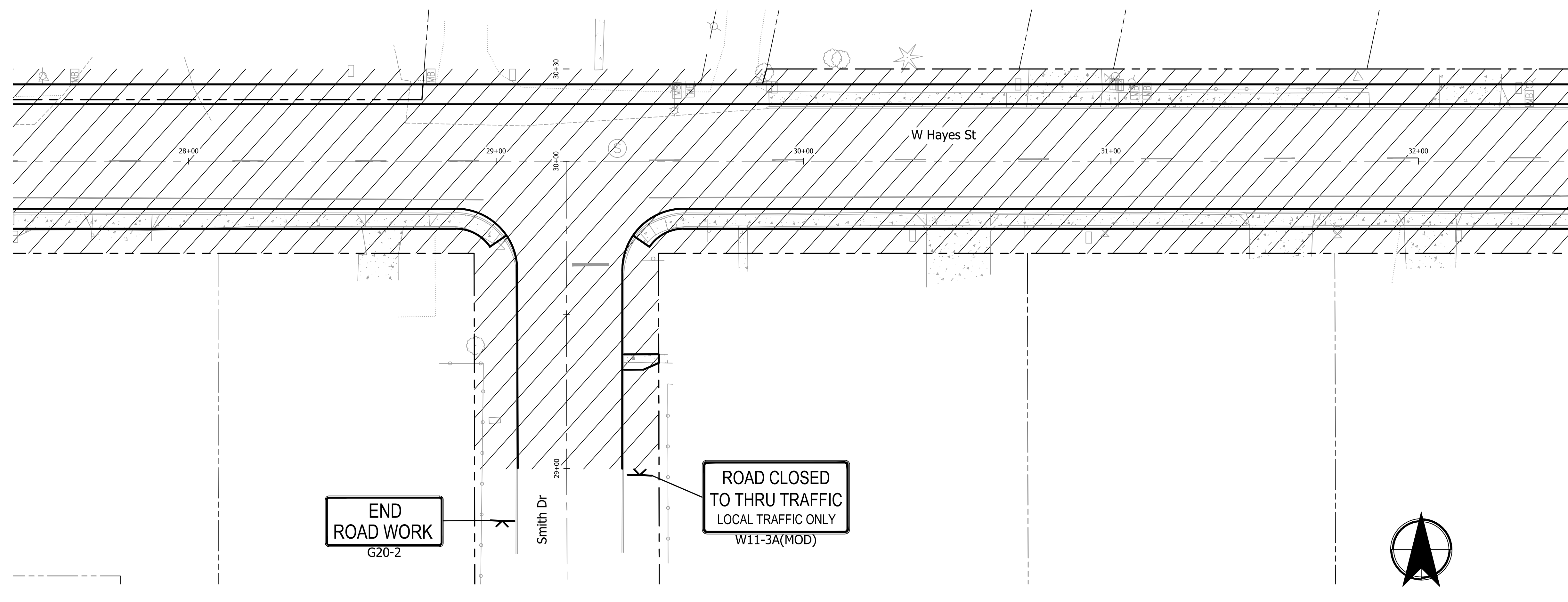
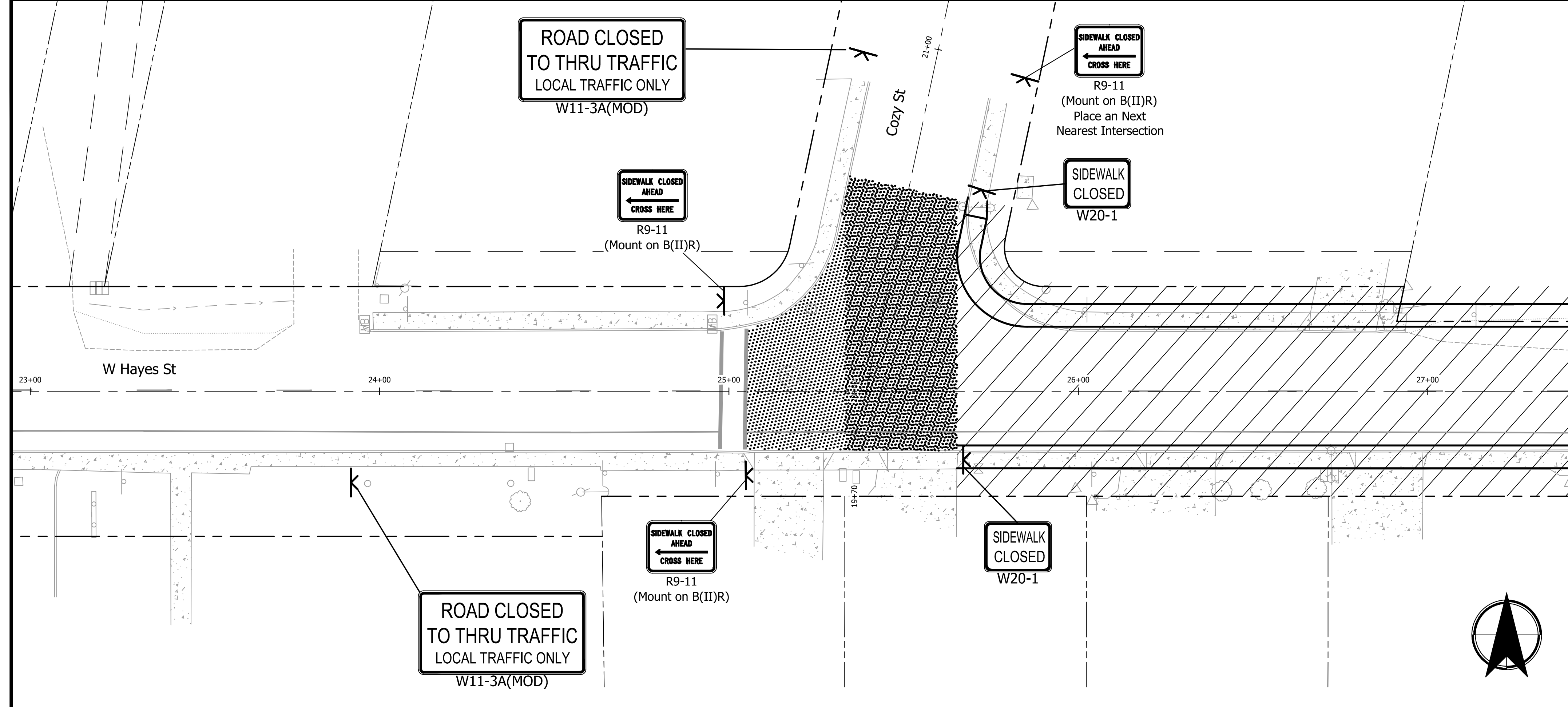





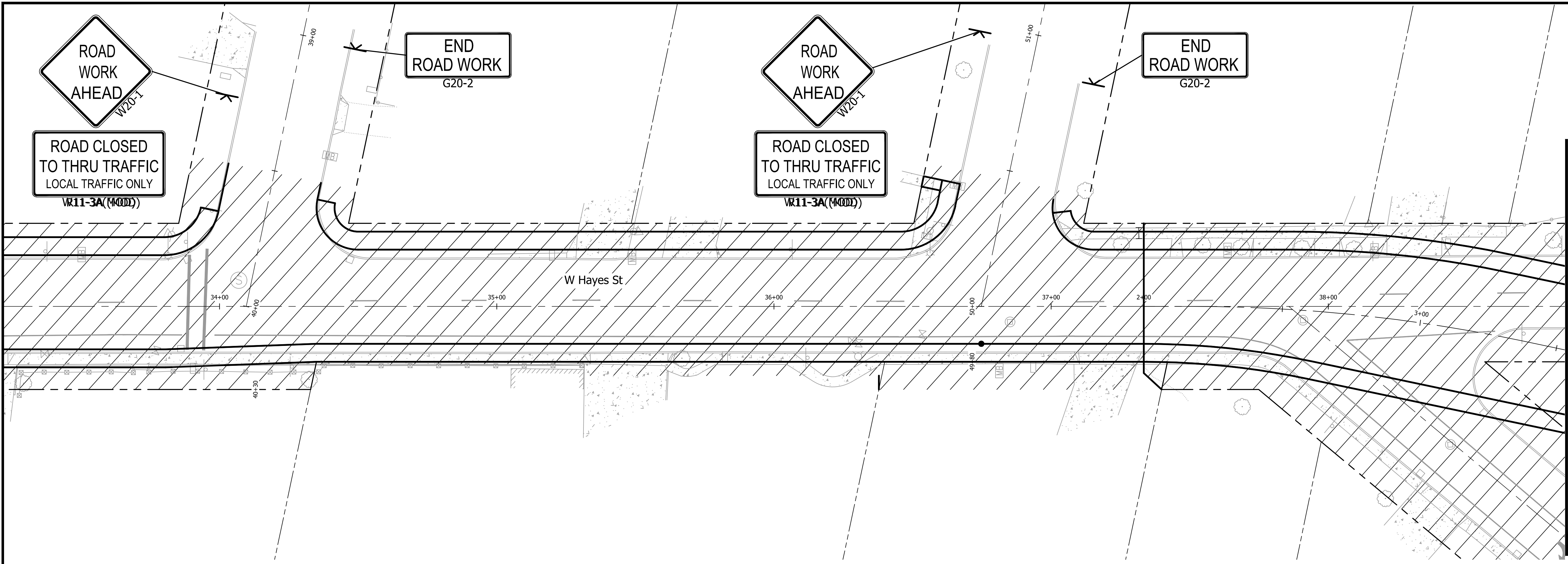

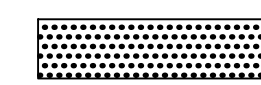

Plot Stamp: 5/27/2022 11:03:44 AM - Fred Wismer
File: H:\24\24512 - W. Hayes Street\design\CD\CD-Traffic-Control-Plans-24512.dwg

Plot Stamp: 5/27/2022 11:03:50 AM - Fred Wismer
 File: H:\24\24512 - W. Hayes Street\design\CD\CD-Traffic-Control-Plans-24512.dwg

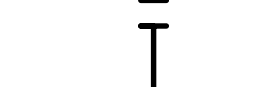

MATCH LINE
SEE SHT 2C-3

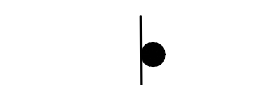
LEGEND

-  UNDER TRAFFIC
-  UNDER CONSTRUCTION
-  28" TUBULAR MARKERS WITH 20' SPACING & 10' SPACING ON TANGENTS, TAPERS AND RADII
-  TYPE III BARRICADE
-  TSS SIGN SUPPORT AS SHOWN ON ODOT STANDARD DRG. TM821
-  PORTABLE SIGN SUPPORT
-  POST MOUNTED CONSTRUCTION SIGN
-  DIRECTION OF TRAFFIC (ARROWS SHOWN FOR ILLUSTRATIVE PURPOSES ONLY)

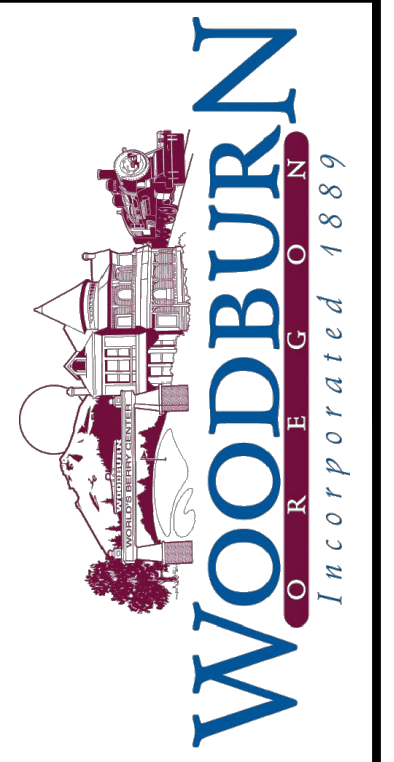
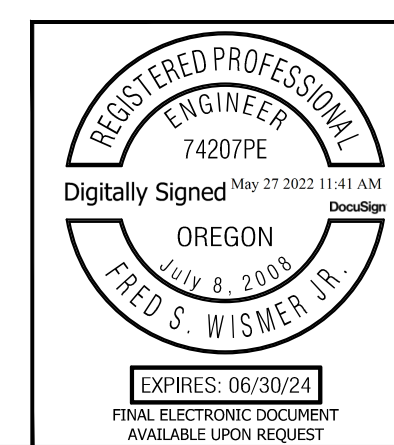
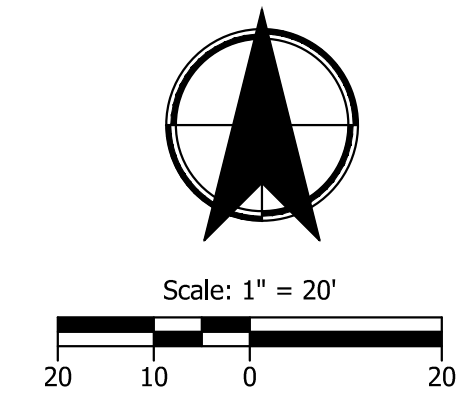

KITTELSON & ASSOCIATES
 851 SW 6TH AVENUE, SUITE 600
 PORTLAND, OR 97204
 P 503.228.5230 F 503.273.8169

#	DATE	REVISION	APP'D
0	05/25/22	ISSUE FOR CONSTRUCTION	FSW

Submission Date:
03/07/2022

Drawn: JCB/RMM
Designed: NRS/JBK
Checked: FSW

PROJECT NO.
2015-001-20

W. Hayes Street Improvements
 Cascade Avenue to Settlemier Avenue
 TRAFFIC CONTROL PLANS - STAGE 1

SHEET NO.
2C-3

NO.	DATE	REVISION	APP'D
0	05/25/22	ISSUE FOR CONSTRUCTION	FSW

Submission Date: 03/07/2022

Drawn: JCB/RMM Designed: NRS/JBK Checked: FSW

PROJECT NO. 2015-001-20





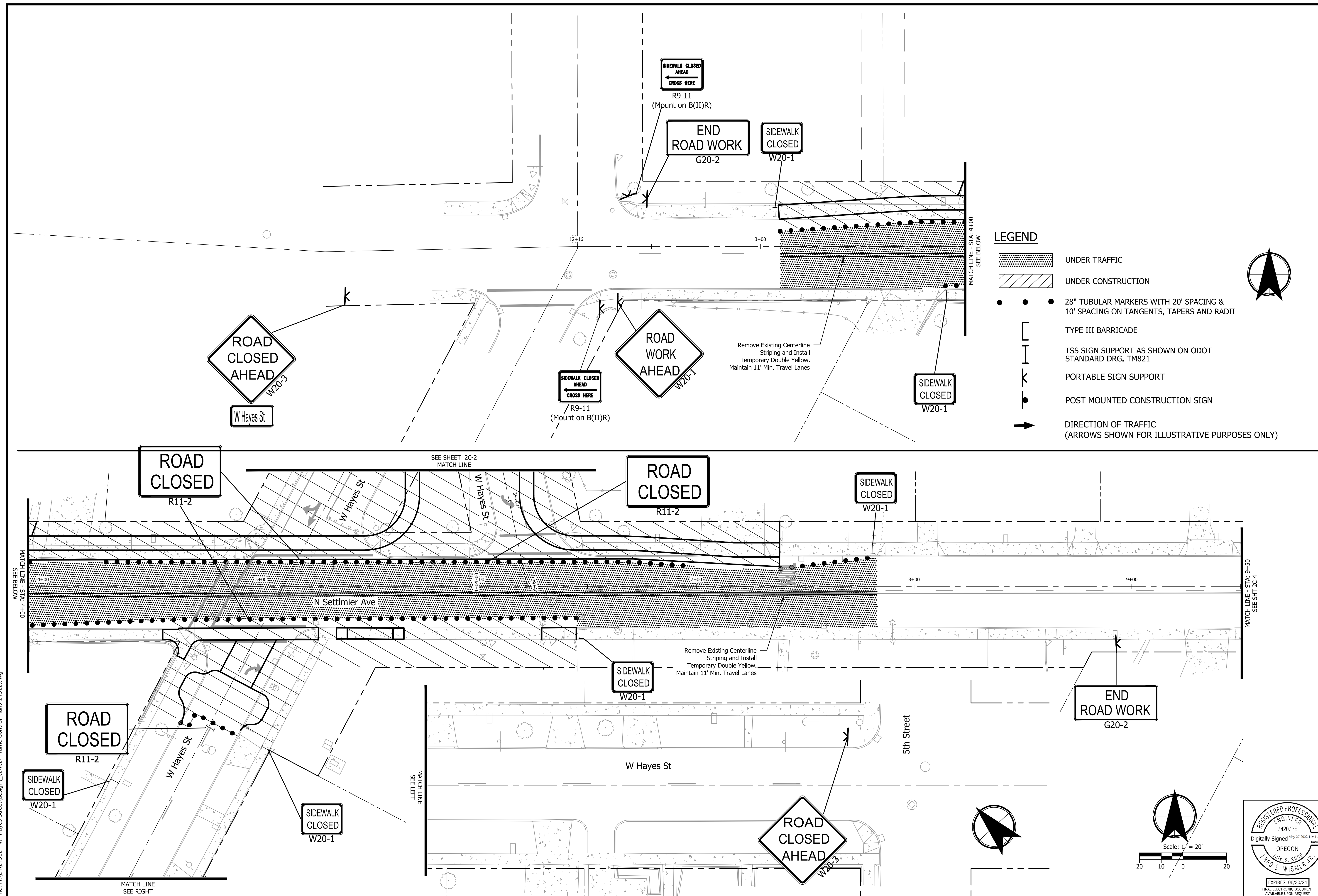

W. Hayes Street Improvements
Cascade Avenue to Settlemier Avenue

TRAFFIC CONTROL PLANS - STAGE 1

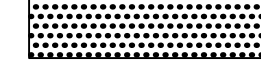
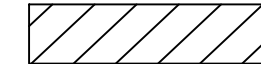
SHEET NO. 2C-4



LEGEND

-  UNDER TRAFFIC
-  UNDER CONSTRUCTION
-  28" TUBULAR MARKERS WITH 20' SPACING & 10' SPACING ON TANGENTS, TAPERS AND RADII
-  TYPE III BARRICADE
-  TSS SIGN SUPPORT AS SHOWN ON ODOT STANDARD DRG. TM821
-  PORTABLE SIGN SUPPORT
-  POST MOUNTED CONSTRUCTION SIGN
-  DIRECTION OF TRAFFIC (ARROWS SHOWN FOR ILLUSTRATIVE PURPOSES ONLY)





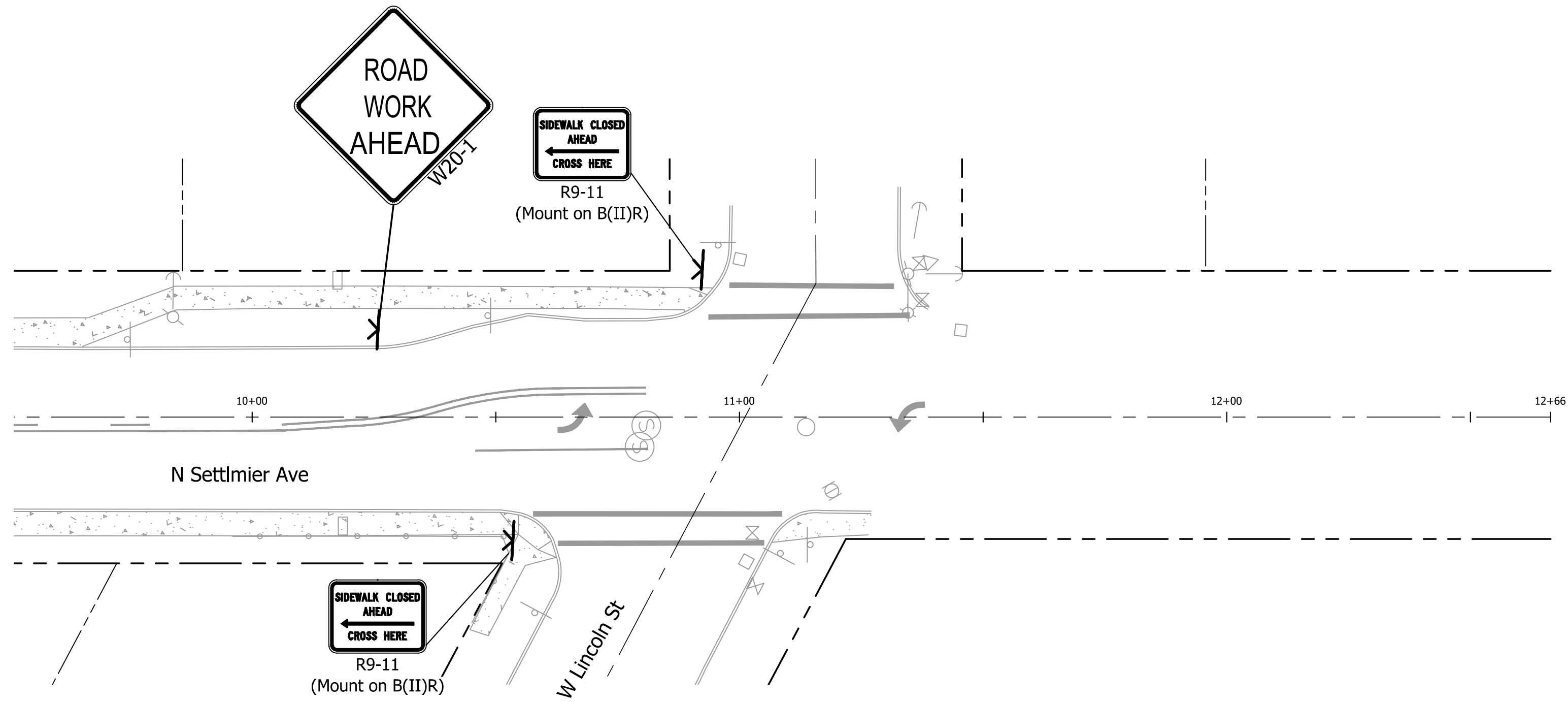

Plot Stamp: 5/27/2022 11:04:01 AM - Fred Wismer
File: H:\24\24512 - W. Hayes Street\design\CD-Traffic-Control-Plans-24512.dwg

REGISTERED PROFESSIONAL ENGINEER
74207PE
Digitally Signed May 27 2022 11:41 AM
OREGON
JULY 8 2008
FRED S. WISMER JR.
EXPIRES: 06/30/24
FINAL ELECTRONIC DOCUMENT
AVAILABLE UPON REQUEST

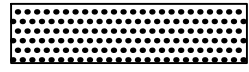
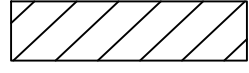
Plot Stamp: 5/27/2022 11:04:10 AM - Fred Wismer
 File: H:\24\24512 - W. Hayes Street\design\CD\CD-Traffic-Control-Plans-24512.dwg



LEGEND

-  UNDER TRAFFIC
-  UNDER CONSTRUCTION
-  28" TUBULAR MARKERS WITH 20' SPACING & 10' SPACING ON TANGENTS, TAPERS AND RADII
-  TYPE III BARRICADE
-  TSS SIGN SUPPORT AS SHOWN ON ODOT STANDARD DRG. TM821
-  PORTABLE SIGN SUPPORT
-  POST MOUNTED CONSTRUCTION SIGN
-  DIRECTION OF TRAFFIC (ARROWS SHOWN FOR ILLUSTRATIVE PURPOSES ONLY)

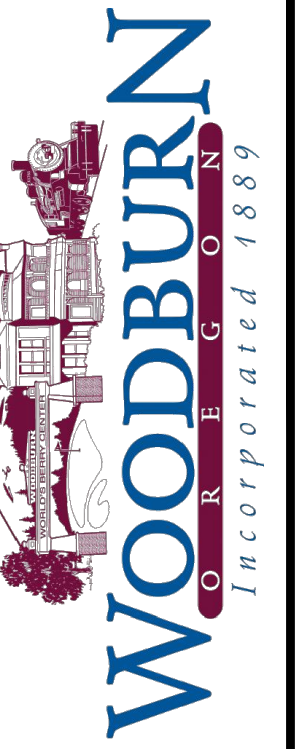
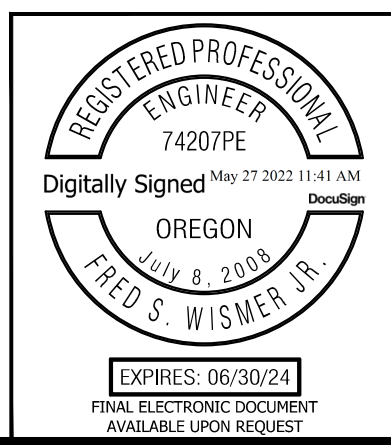
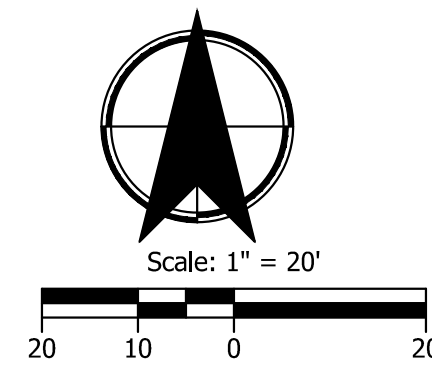

KITTELSON & ASSOCIATES
 851 SW 6TH AVENUE, SUITE 600
 PORTLAND, OR 97204
 P 503.228.5230 F 503.273.8169

NO.	DATE	REVISION
0	05/25/22	ISSUE FOR CONSTRUCTION
		APP'D

Submission Date: 03/07/2022
 Drawn: JCB/RMM
 Designed: NRS/JBK
 Checked: FSW

PROJECT NO. 2015-001-20

W. Hayes Street Improvements
 Cascade Avenue to Settlemier Avenue
 TRAFFIC CONTROL PLANS - STAGE 1

SHEET NO. 2C-5

#	DATE	REVISION	APP'D
0	05/25/22	ISSUE FOR CONSTRUCTION	FSW

Submission Date:	03/07/2022
Drawn:	JCB/RMM
Designed:	NRS/JBK
Checked:	FSW





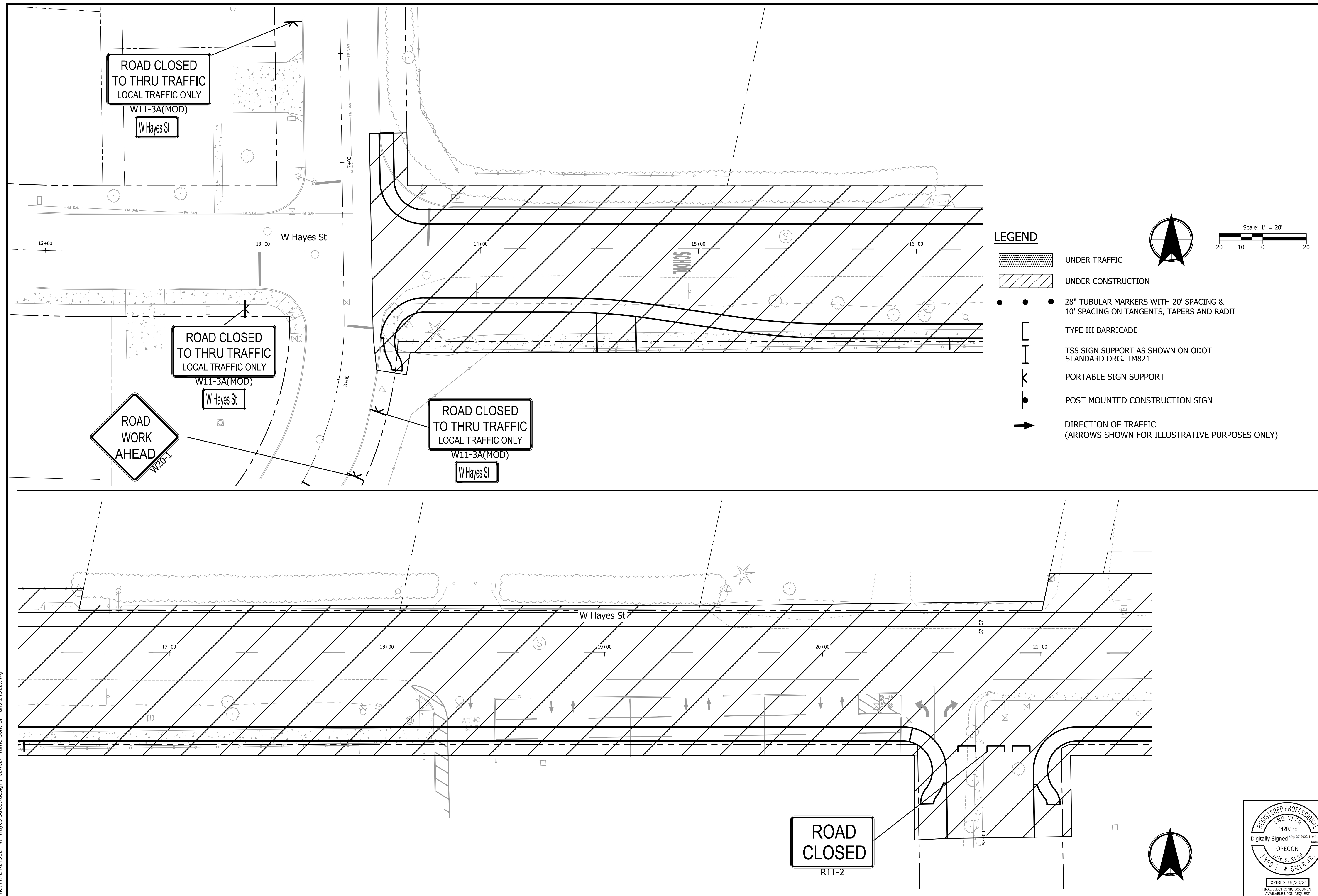

PROJECT NO.
2015-001-20

W. Hayes Street Improvements
Cascade Avenue to Settlemier Avenue

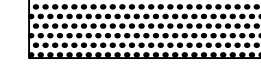
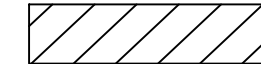
TRAFFIC CONTROL PLANS - STAGE 2

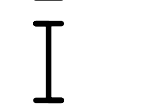

LEGEND



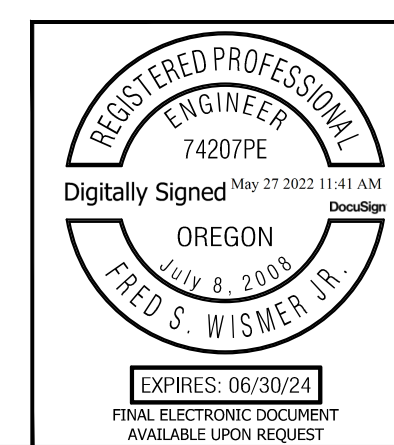

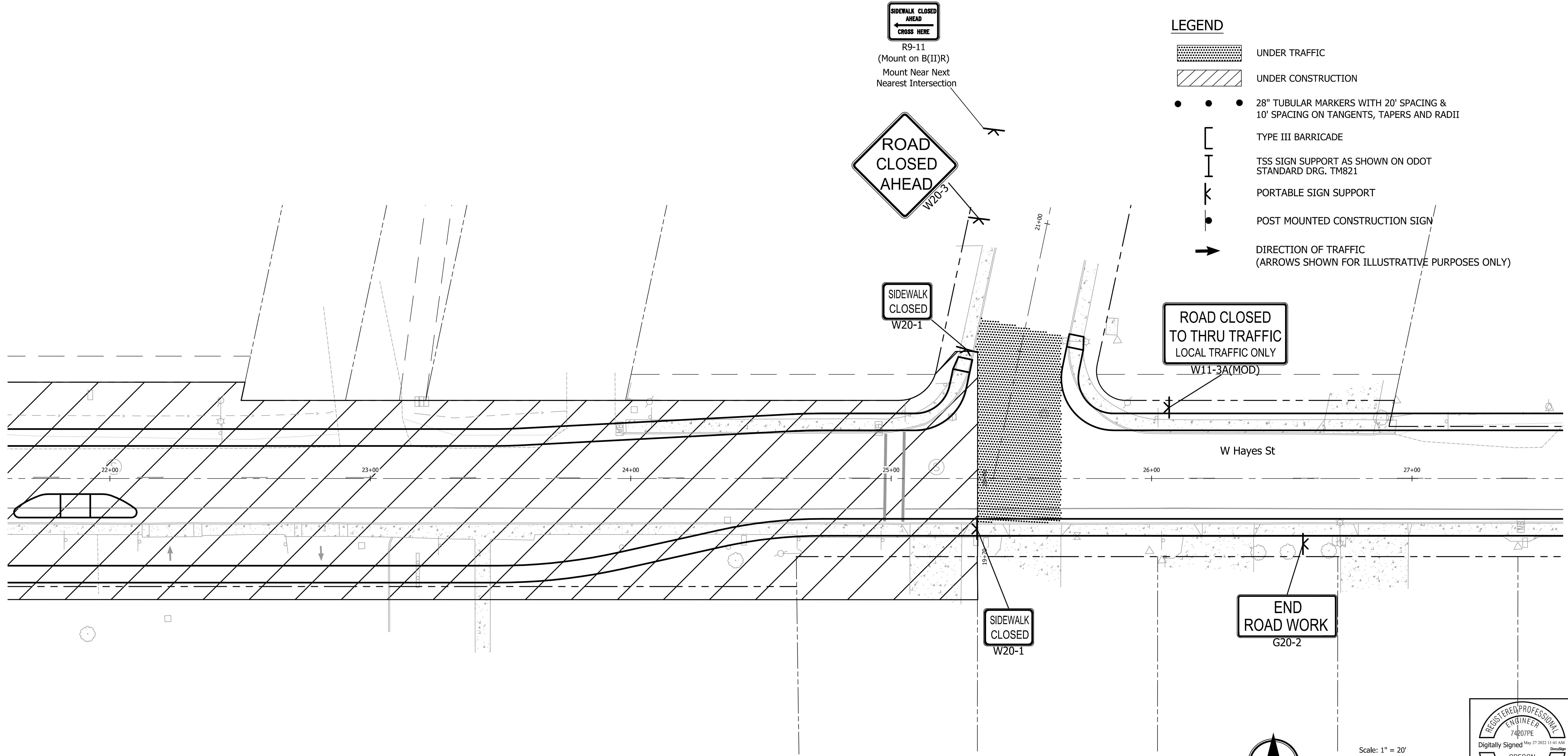

-  UNDER TRAFFIC
-  UNDER CONSTRUCTION
-  28" TUBULAR MARKERS WITH 20' SPACING & 10' SPACING ON TANGENTS, TAPERS AND RADII
-  TYPE III BARRICADE
-  TSS SIGN SUPPORT AS SHOWN ON ODOT STANDARD DRG. TM821
-  PORTABLE SIGN SUPPORT
-  POST MOUNTED CONSTRUCTION SIGN
-  DIRECTION OF TRAFFIC (ARROWS SHOWN FOR ILLUSTRATIVE PURPOSES ONLY)

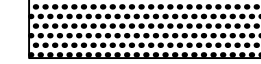
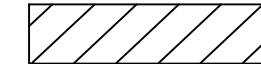

Plot Stamp: 5/27/2022 11:04:26 AM - Fred Wismer
 File: H:\24\24512 - W. Hayes Street\design\CD\CD-Traffic-Control-Plans-24512.dwg

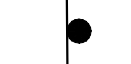

LEGEND

-  UNDER TRAFFIC
-  UNDER CONSTRUCTION
-  28" TUBULAR MARKERS WITH 20' SPACING & 10' SPACING ON TANGENTS, TAPERS AND RADII
-  TYPE III BARRICADE
-  TSS SIGN SUPPORT AS SHOWN ON ODOT STANDARD DRG. TM821
-  PORTABLE SIGN SUPPORT
-  POST MOUNTED CONSTRUCTION SIGN
-  DIRECTION OF TRAFFIC (ARROWS SHOWN FOR ILLUSTRATIVE PURPOSES ONLY)

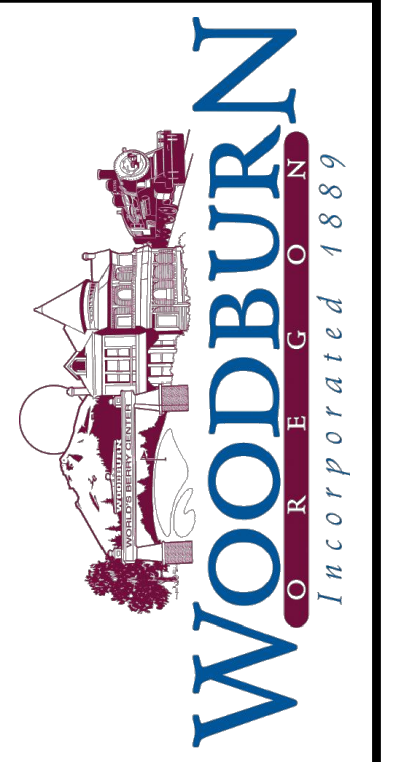

KITTELSON & ASSOCIATES
 851 SW 6TH AVENUE, SUITE 600
 PORTLAND, OR 97204
 P 503.228.5230 F 503.273.8169

#	DATE	REVISION	APP'D
0	05/25/22	ISSUE FOR CONSTRUCTION	FSW

Submission Date: 03/07/2022

Drawn: JCB/RMM Designed: NRS/JBK Checked: FSW

PROJECT NO. 2015-001-20

W. Hayes Street Improvements
 Cascade Avenue to Settlemier Avenue
 TRAFFIC CONTROL PLANS - STAGE 2

SHEET NO. 2C-7

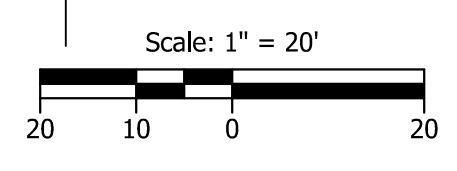
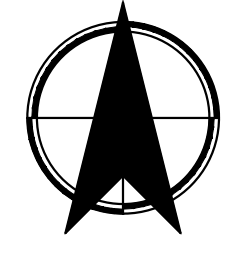
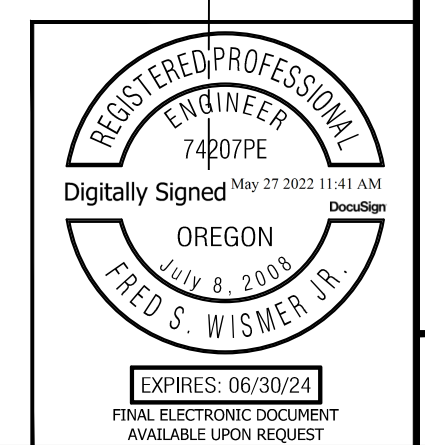

W HAYES STREET IMPROVEMENTS GRADING & EROSION CONTROL

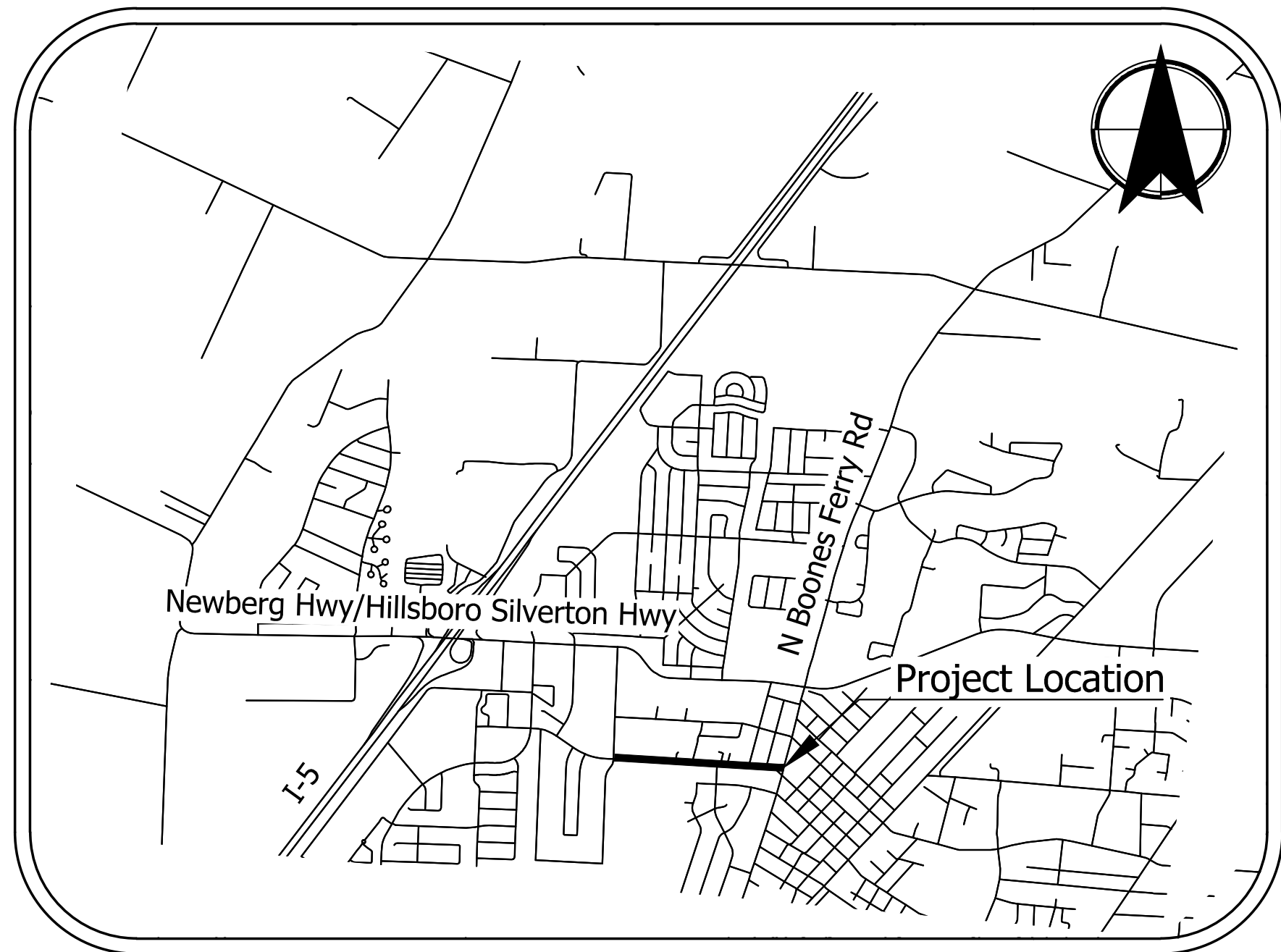
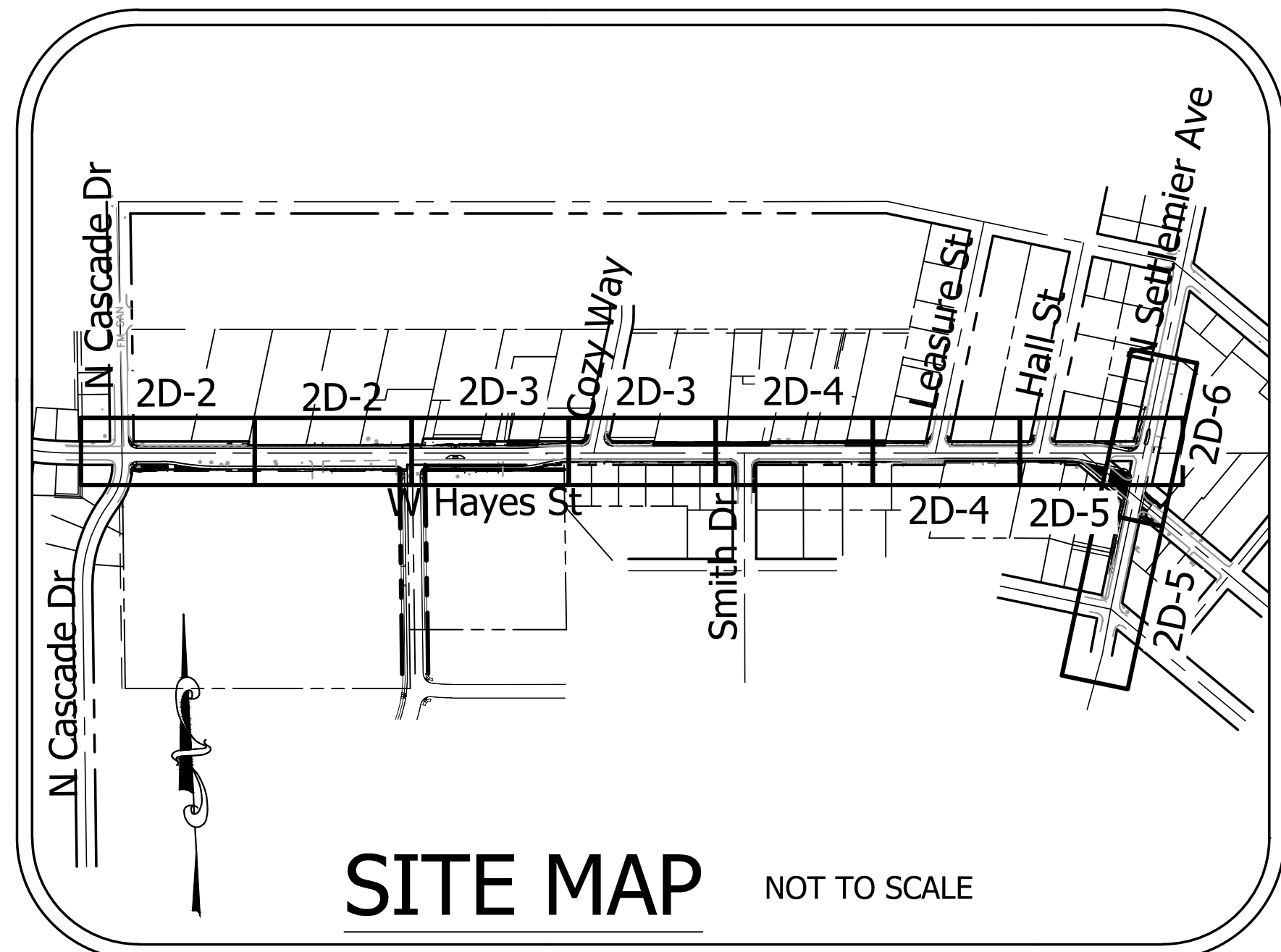

Inspection Frequency

Site Condition	Minimum Frequency
1. Active Period	On the initial date; Within 24 hours of any storm event, including runoff from snow melt, that results in discharge from the site. At least once every 14 days, regardless of whether stormwater runoff is occurring.
2. Inactive periods greater than fourteen (14) consecutive calendar days.	The Inspector may reduce the frequency of inspections in any area of the site where the stabilization steps in Section 2.2.20 have been completed to twice per month for the first month, no less than 14 calendar days apart, then once per month.
3. Periods during which the site is inaccessible due to inclement weather.	If safe, accessible and practical, inspections must occur daily at a relevant discharge point or downstream location of the receiving waterbody.
4. Periods during which construction activities are suspended and runoff is unlikely due to frozen conditions.	Visual monitoring inspections may be temporarily suspended. Immediately resume monitoring upon thawing, or when weather conditions make discharges likely.
5. Periods during which construction activities are conducted and runoff is unlikely during frozen conditions.	Visual monitoring inspections may be reduced to once a month. Immediately resume monitoring upon thawing, or when weather conditions make discharges likely.

Project Location
East of I-5 along W. Hayes St. between Cascade Ave. and Settlemier Ave.

Rain Gauge
Aurora State Airport
Hyperlink: <https://w1.weather.gov/data/obhistory/KUAO.html>

The Permittee is required to meet all the conditions of the 1200C Permit. This ESCP and General Conditions have been developed to facilitate compliance with the 1200C Permit requirements. In cases of discrepancies or omissions, the 1200C Permit Requirements supercede requirements of this plan. Contractor is responsible for staging area & associated ESC measures.

Sheet Index

2D	Grading & Erosion Control Cover Sheet
2D-2 Thru 2D-6	Grading & Erosion Control Sheets
2D-7	Grading & Erosion Control Details

Business Days/Hours

Monday - Friday	7:00-7:00
Saturday	-No Work-
Sunday	-No Work-

Owner/Developer
City of Woodburn
Contact: Dago Garcia
190 Garfield Street
Woodburn, OR 97071
Phone: 503-982-5248
Email: dago.garcia@ci.woodburn.or.us

Surveyor
Emerio
Contact: Eric Lynch, PLS
6445 SW Fallbrook Place, Suite 100
Beaverton, OR 97008
Phone: 503-746-8812
Email: ericd@emeriodesign.com

Design Engineer/ESCP Preparer
Kittelston and Associates, Inc.
Contact: Fred Wismer, PE
851 SW 6th Ave., Suite 600
Portland, OR 97204
Phone: 503-228-5230
Email: fwismer@kittelston.com

General Contractor
TBD

CESSL
TBD

BMP Installer/Maintainer
TBD

Site Information

- Type of Development:** Public Roadway Improvements
- Construction Activity will consist of:**
 - A) Curb, Asphalt Paving, & Sidewalk Construction
 - B) Stormwater Drainage System (Piping & Treatment Facilities)
 - C) Utility Relocations
- Project Timeline:**
Beginning Date: Summer 2022
Completion Date: Summer 2023
- Project Offsite Areas:**
Total Area: 4.2 Acres
Disturbed Area: 3.9 Acres
Percent of Area Disturbed: 93%
- Soil Types:**
Amity Silt Loam (88.5%)
Dayton Silt Loam (7.4%)
Woodburn Silt Loam (4.1%)
- Receiving Water Bodies**
Mill Creek
- Cut and Fill Data:**
Cut: 5,999 CY
Fill: 239 CY

DEQ Erosion and Sediment Control Plan Drawing Notes:

- Once known, include a list of all contractors that will engage in construction activities on site, and the areas of the site where the contractor(s) will engage in construction activities. Revise the list as appropriate until permit coverage is terminated (Section 4.4.c.i). In addition, include a list of all personnel (by name and position) that are responsible for the design, installation and maintenance of stormwater control measures (e.g. ESCP developer, BMP installer (see Section 4.10), as well as their individual responsibilities. (Section 4.4.c.i)
- Visual monitoring inspection reports must be made in accordance with DEQ 1200-C permit requirements. (Section 6.5)
- Inspection logs must be kept in accordance with DEQ's 1200-C permit requirements. (Section 6.5.a)
- Retain a copy of the ESCP and all revisions on site and make it available on request to DEQ, Agent, or the local municipality. (Section 4.7)
- The permit registrant must implement the ESCP. Failure to implement any of the control measures or practices described in the ESCP is a violation of the permit. (Sections 4 and 4.11)
- The ESCP must be accurate and reflect site conditions. (Section 4.8)
- Submission of all ESCP revisions is not required. Submittal of the ESCP revisions is only under specific conditions. Submit all necessary revision to DEQ or Agent within 10 days. (Section 4.9)
- Sequence clearing and grading to the maximum extent practical to prevent exposed inactive areas from becoming a source of erosion. (Section 2.2.2)
- Create smooth surfaces between soil surface and erosion and sediment controls to prevent stormwater from bypassing controls and ponding. (Section 2.2.3)
- Identify, mark, and protect (by construction fencing or other means) critical riparian areas and vegetation including important trees and associated rooting zones, and vegetation areas to be preserved. Identify vegetative buffer zones between the site and sensitive areas (e.g., wetlands), and other areas to be preserved, especially in perimeter areas. (Section 2.2.1)
- Preserve existing vegetation when practical and re-vegetate open areas. Re-vegetate open areas when practicable before and after grading or construction. Identify the type of vegetative seed mix used. (Section 2.2.5)
- Maintain and delineate any existing natural buffer within the 50-foot of waters of the state. (Section 2.2.4)
- Install perimeter sediment control, including storm drain inlet protection as well as all sediment basins, traps, and barriers prior to land disturbance. (Sections 2.1.3)
- Control both peak flow rates and total stormwater volume, to minimize erosion at outlets and downstream channels and streambanks. (Sections 2.1.1 and 2.2.16)
- Control sediment as needed along the site perimeter and at all operational internal storm drain inlets at all times during construction, both internally and at the site boundary. (Sections 2.2.6 and 2.2.13)
- Establish concrete truck and other concrete equipment washout areas before beginning concrete work. (Section 2.2.14)
- Apply temporary and/or permanent soil stabilization measures immediately on all disturbed areas as grading progresses. Temporary or permanent stabilizations measures are not required for areas that are intended to be left unvegetated, such as dirt access roads or utility pole pads. (Sections 2.2.20 and 2.2.21)
- Establish material and waste storage areas, and other non-stormwater controls. (Section 2.3.7)
- Keep waste container lids closed when not in use and close lids at the end of the business day for those containers that are actively used throughout the day. For waste containers that do not have lids, provide either (1) cover (e.g., a tarp, plastic sheeting, temporary roof) to prevent exposure of wastes to precipitation, or (2) a similarly effective means designed to prevent the discharge of pollutants (e.g., secondary containment). (Section 2.3.7)
- Prevent tracking of sediment onto public or private roads using BMPs such as: construction entrance, graveled (or paved) exits and parking areas, gravel all unpaved roads located onsite, or use an exit tire wash. These BMPs must be in place prior to land-disturbing activities. (Section 2.2.7)
- When trucking saturated soils from the site, either use water-tight trucks or drain loads on site. (Section 2.2.7.f)
- Control prohibited discharges from leaving the construction site, i.e., concrete wash-out, wastewater from cleanout of stucco, paint and curing compounds. (Sections 1.5 and 2.3.9)
- Ensure that steep slope areas where construction activities are not occurring are not disturbed. (Section 2.2.10)
- Prevent soil compaction in areas where post-construction infiltration facilities are to be installed. (Section 2.2.12)
- Use BMPs to prevent or minimize stormwater exposure to pollutants from spills; vehicle and equipment fueling, maintenance, and storage; other cleaning and maintenance activities; and waste handling activities. These pollutants include fuel, hydraulic fluid, and other oils from vehicles and machinery, as well as debris, fertilizer, pesticides and herbicides, paints, solvents, curing compounds and adhesives from construction operations. (Sections 2.2.15 and 2.3)
- Provide plans for sedimentation basins that have been designed per Section 2.2.17 and stamped by an Oregon Professional Engineer. (See Section 2.2.17.a)
- If engineered soils are used on site, a sedimentation basin/impoundment must be installed. (See Sections 2.2.17 and 2.2.18)
- Provide a dewatering plan for accumulated water from precipitation and uncontaminated groundwater seepage due to shallow excavation activities. (See Section 2.4)
- Implement the following BMPs when applicable: written spill prevention and response procedures, employee training on spill prevention and proper disposal procedures, spill kits in all vehicles, regular maintenance schedule for vehicles and machinery, material delivery and storage controls, tracing and signage, and covered storage areas for waste and supplies. (Section 2.3)
- Use water, soil-binding agent or other dust control technique as needed to avoid wind-blown soil. (Section 2.2.9)
- The application rate of fertilizers used to reestablish vegetation must follow manufacturer's recommendations to minimize nutrient releases to surface waters. Exercise caution when using time-release fertilizers within any waterway riparian zone. (Section 2.3.5)
- If an active treatment system (for example, electro-coagulation, flocculation, filtration, etc.) for sediment or other pollutant removal is employed, submit an operation and maintenance plan (including system schematic, location of system, location of inlet, location of discharge, discharge dispersion device design, and a sampling plan and frequency) before operating the treatment system. Obtain Environmental Management Plan approval from DEQ before operating the treatment system. Operate and maintain the treatment system according to manufacturer's specifications. (Section 1.2.9)
- Temporarily stabilize soils at the end of the shift before holidays and weekends, if needed. The registrant is responsible for ensuring that soils are stable during rain events at all times of the year. (Section 2.2)
- As needed based on weather conditions, at the end of each workday soil stockpiles must be stabilized or covered, or other BMPs must be implemented to prevent discharges to surface waters or conveyance systems leading to surface waters. (Section 2.2.8)
- Sediment fence: remove trapped sediment before it reaches one third of the above ground fence height and before fence removal. (Section 2.1.5.b)
- Other sediment barriers (such as biobags): remove sediment before it reaches two inches depth above ground height and before BMP removal. (Section 2.1.5.c)
- Catch basins: clean before retention capacity has been reduced by fifty percent. Sediment basins and sediment traps: remove trapped sediments before design capacity has been reduced by fifty percent and at completion of project. (Section 2.1.5.d)
- Within 24 hours, significant sediment that has left the construction site, must be remediated. Investigate the cause of the sediment release and implement steps to prevent a recurrence of the discharge within the same 24 hours. Any in-stream clean-up of sediment shall be performed according to the Oregon Department of State Lands required timeframe. (Section 2.2.19.a)
- The intentional washing of sediment into storm sewers or drainage ways must not occur. Vacuuming or dry sweeping and material pickup must be used to clean up released sediments. (Section 2.2.19)
- Document any portion(s) of the site where land disturbing activities have permanently ceased or will be temporarily inactive for 14 or more calendar days. (Section 6.5.f)
- Provide temporary stabilization for that portion of the site where construction activities cease for 14 days or more with a covering of blown straw and a tackifier, loose straw, or an adequate covering of compost mulch until work resumes on that portion of the site. (Section 2.2.20)
- Do not remove temporary sediment control practices until permanent vegetation or other cover of exposed areas is established. Once construction is complete and the site is stabilized, all temporary erosion controls and retained soils must be removed and disposed of properly, unless needed for long term use following termination of permit coverage. (Section 2.2.21)

BMP Matrix for Construction Phase

Phase/BMP	2022-2023				2023
	CLEARING	MASS GRADING	UTILITY CONSTRUCTION	STREET CONSTRUCTION	
EROSION PREVENTION					
PRESERVE NATURAL VEGETATION	* X	X	X	X	X
GROUND COVER					X
HYDRAULIC APPLICATIONS					X
PLASTIC SHEETING					X
MATTING					X
DUST CONTROL	X	X	X	X	X
TEMPORARY PERMANENT SEEDING					X
OTHER: BUFFER ZONE					
SEDIMENT CONTROL					
SEDIMENT FENCE (PERIMETER)	* X	X	X	X	X
SEDIMENT FENCE (INTERIOR)					X
STRAW MATS					X
FILTER BERM					X
INLET PROTECTION	X	X	X	X	X
DEWATERING					X
SEDIMENT TRAP					X
NATURAL BUFFER ENCROACHMENT					
OTHER:					
RUN OFF CONTROL					
CONSTRUCTION ENTRANCE	X	X	X	X	
PIPE SLOPE DRAIN					
OUTLET PROTECTION					
SURFACE ROUGHENING					
CHECK DAMS					
OTHER:					
POLLUTION PREVENTION					
PROPER SIGNAGE	X	X	X	X	X
HAZ WASTE MGMT	X	X	X	X	X
SPILL KIT ON-SITE	X	X	X	X	X
CONCRETE WASHOUT AREA	X	X	X	X	X
OTHER:					

* Signifies BMP that will be installed prior to any ground disturbing activity.

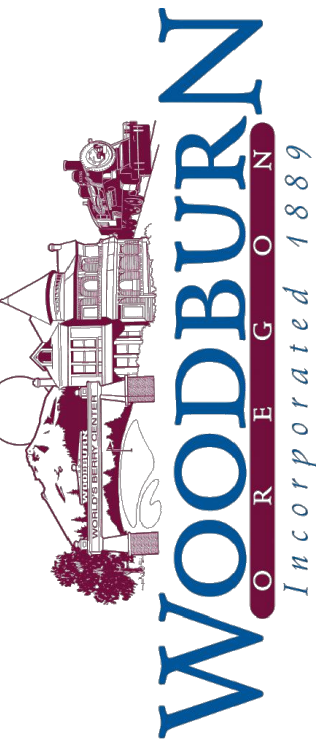

KITTELSTON & ASSOCIATES

851 SW 6TH AVENUE, SUITE 600
PORTLAND, OR 97204
P 503.228.5230 F 503.273.8169

0	05/25/23	#	DATE	APP'D
			ISSUE FOR CONSTRUCTION	FSW
			REVISION	APP'D

Submission Date:
03/07/2022

Drawn: JCB/RMM Designed: NRS/JBK Checked: FSW

PROJECT NO.
2015-001-20

W. Hayes Street Improvements
Cascade Avenue to Settlemier Avenue

GRADING AND EROSION CONTROL COVER SHEET

SHEET NO.
2D

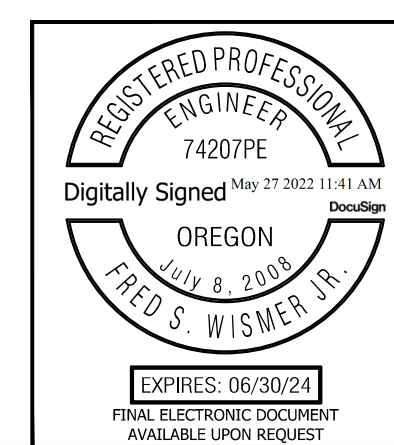

Plot Stamp: 5/27/2022 11:07:06 AM - Fred Wismer
 File: H:\24\24512 - W. Hayes Street\design\CD\CD-Grading and Erosion Control-24512.dwg

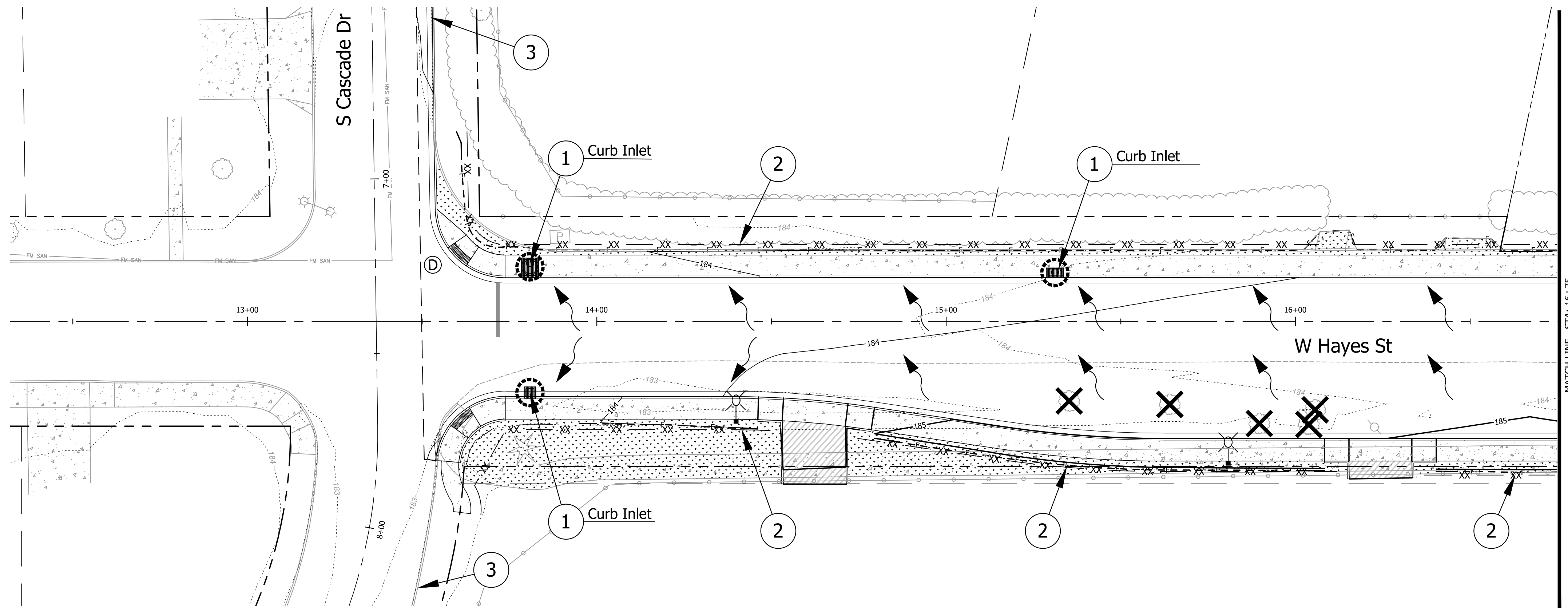

LEGEND

- XX — XX — XX — XX — Sediment Fence
- — — — Existing ROW Line
- — — — Proposed ROW Line
- - - - 250 Existing Major Contours
- · · · 249 Existing Minor Contours
- — — — 250 Proposed Major Contours
- · · · 249 Proposed Minor Contours
- Flow Arrow
- Ⓧ Ⓧ Extg./Proposed MH
- Ⓧ Ⓧ Extg./Proposed CB
- Ⓧ Ⓧ Inlet Protection
- Ⓧ Concrete Washout Facility
- ★ Trees to Remain
- ✕ ✕ Trees to Removed

CONSTRUCTION NOTES

- 1 Install Inlet Protection.
(For Details, See Sht. 2D-7)
- 2 Install Sediment Fence.
(For Details, See Sht. 2D-7)
- 3 Install Inlet Protection at Next Nearest Inlet
Inlet Not Shown
(For Details, See Sht. 2D-7)

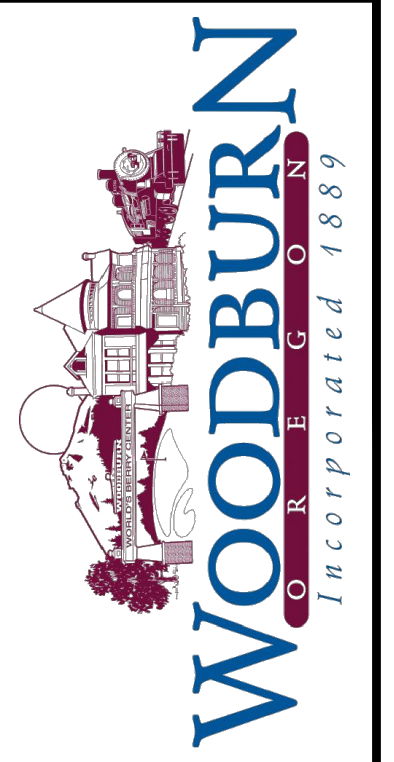
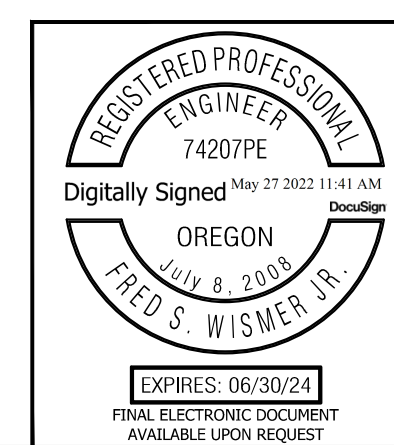
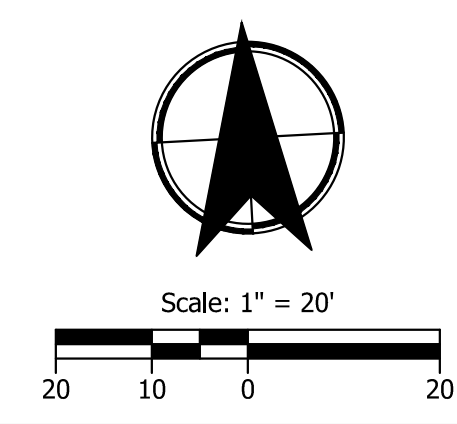
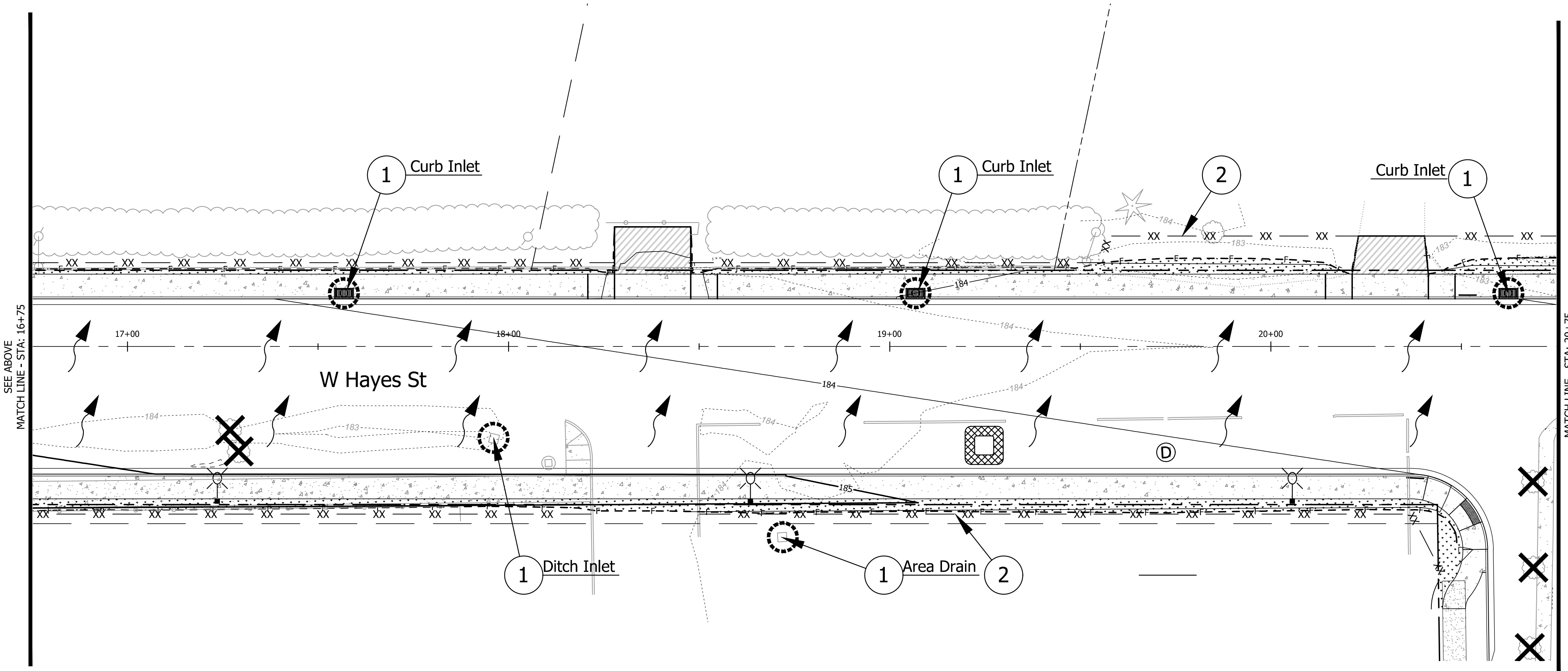

KITTELSON & ASSOCIATES
 851 SW 6TH AVENUE, SUITE 600
 PORTLAND, OR 97204
 P 503.228.5230 F 503.273.8169

DATE	REVISION	APP'D	FSW
01/05/25/22	ISSUE FOR CONSTRUCTION		

Submission Date: 03/07/2022
 Drawn: JCB/RMM Designed: NRS/JBK Checked: FSW
 PROJECT NO. 2015-001-20

W. Hayes Street Improvements
 Cascade Avenue to Settlemier Avenue
 GRADING AND EROSION CONTROL PLAN

SHEET NO. 2D-2

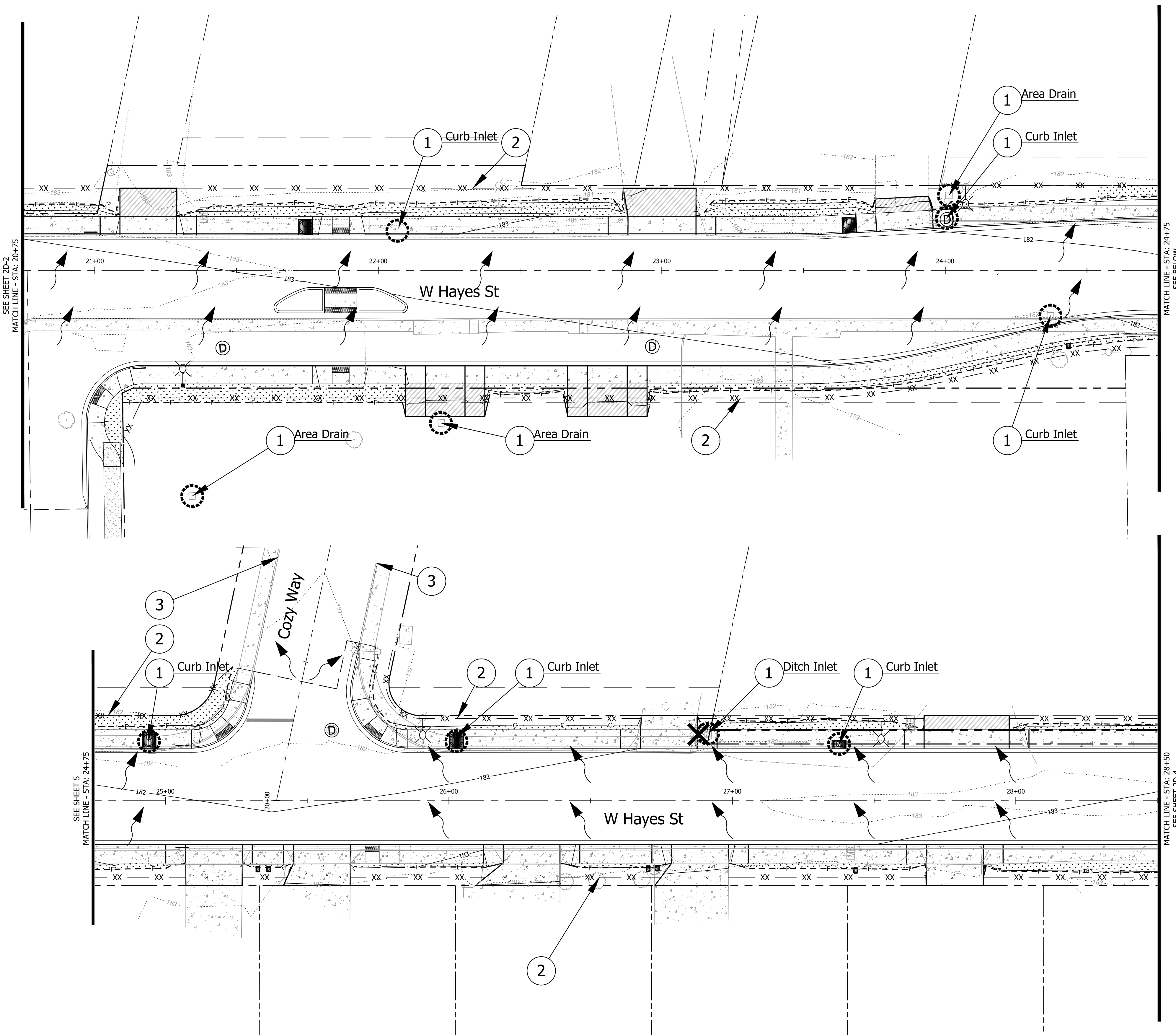

LEGEND

- XX — XX — XX — XX — Sediment Fence
- — — — Existing ROW Line
- — — — Proposed ROW Line
- - - - 250 Existing Major Contours
- - - - 249 Existing Minor Contours
- - - - 250 Proposed Major Contours
- - - - 249 Proposed Minor Contours
- Flow Arrow
- ⊕ ⊕ Extg./Proposed MH
- ⊞ ⊞ Extg./Proposed CB
- ⊞ ⊞ Inlet Protection
- ⊞ ⊞ Concrete Washout Facility
- ★ ○ Trees to Remain
- ✕ ✕ Trees to Removed

CONSTRUCTION NOTES

- 1 Install Inlet Protection.
(For Details, See Sht. 2D-7)
- 2 Install Sediment Fence.
(For Details, See Sht. 2D-7)
- 3 Install Inlet Protection at Next Nearest Inlet
Inlet Not Shown
(For Details, See Sht. 2D-7)

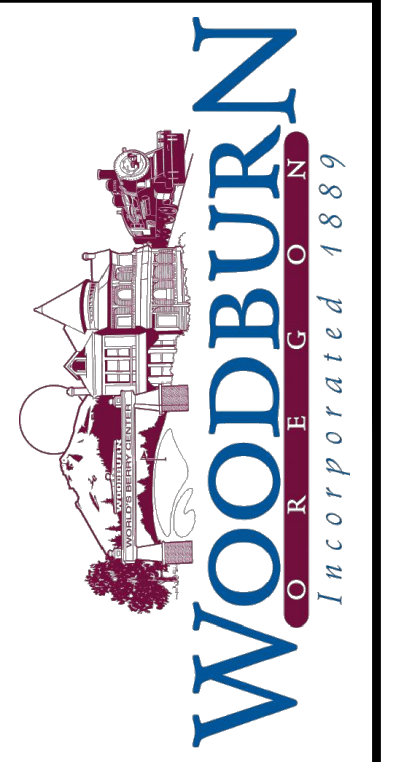
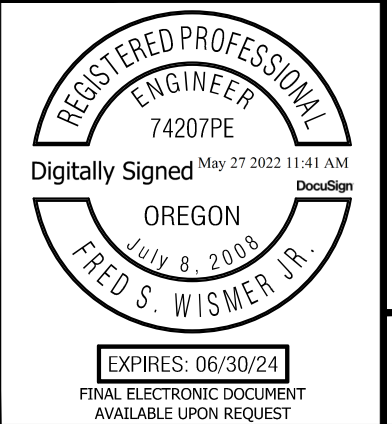
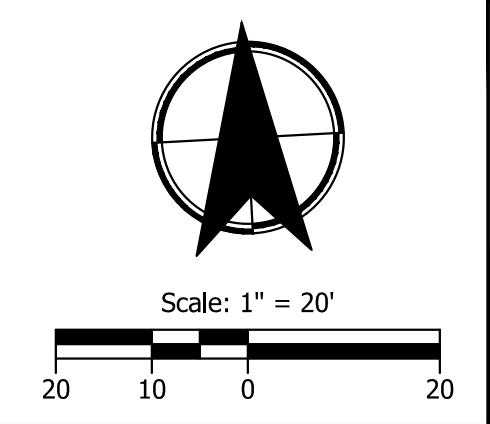

KITTELSON & ASSOCIATES
 851 SW 6TH AVENUE, SUITE 600
 PORTLAND, OR 97204
 P 503.228.5230 F 503.273.8169

DATE	REVISION	APP'D
01/05/25/22	ISSUE FOR CONSTRUCTION	FSW

Submission Date: 03/07/2022
 Drawn: JCB/RMM Designed: NRS/JBK Checked: FSW

PROJECT NO. 2015-001-20
W. Hayes Street Improvements
 Cascade Avenue to Settlemier Avenue
 GRADING AND EROSION CONTROL PLAN
 SHEET NO. 2D-3

Plot Stamp: 5/27/2022 11:07:26 AM - Fred Wismer
 File: H:\24\24512 - W. Hayes Street\design\CD\CD-Grading and Erosion Control-24512.dwg

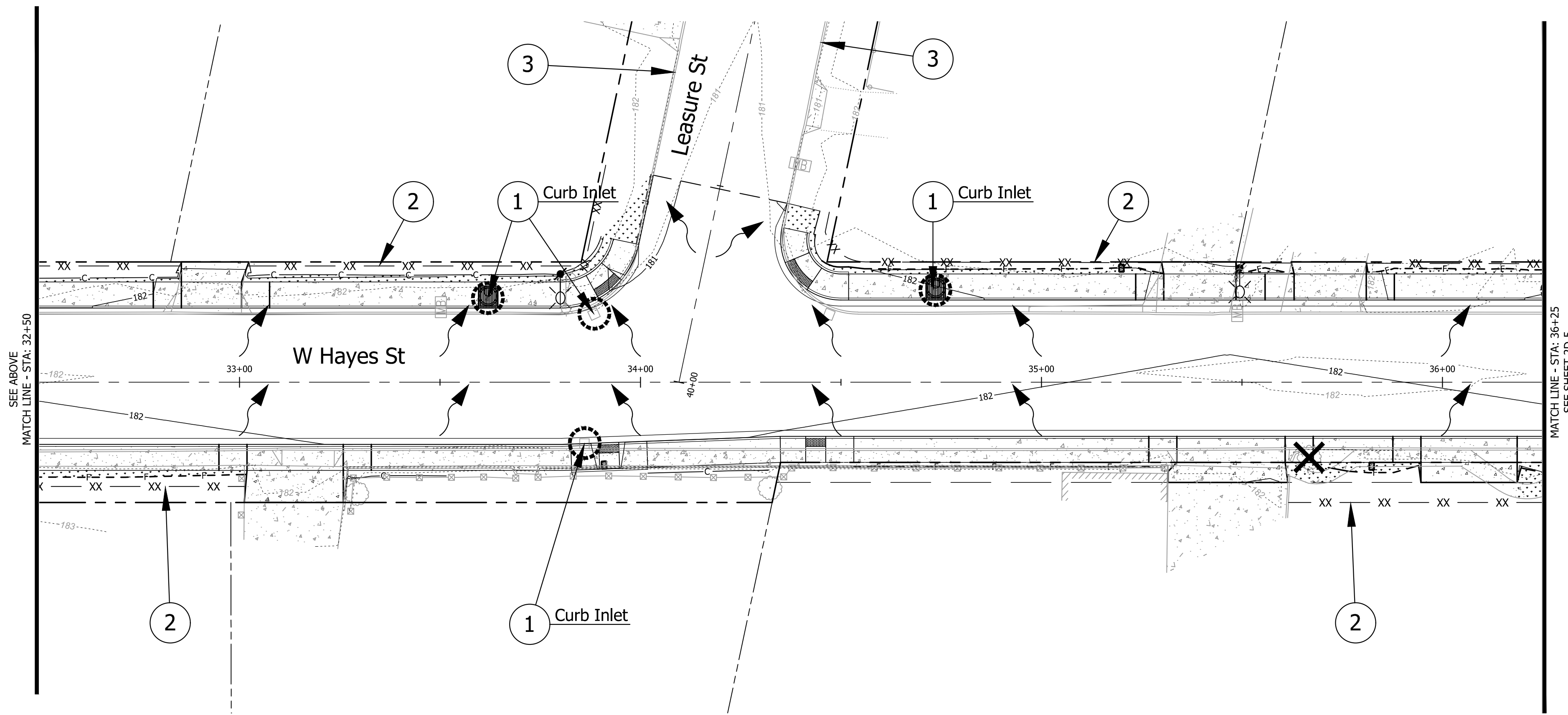
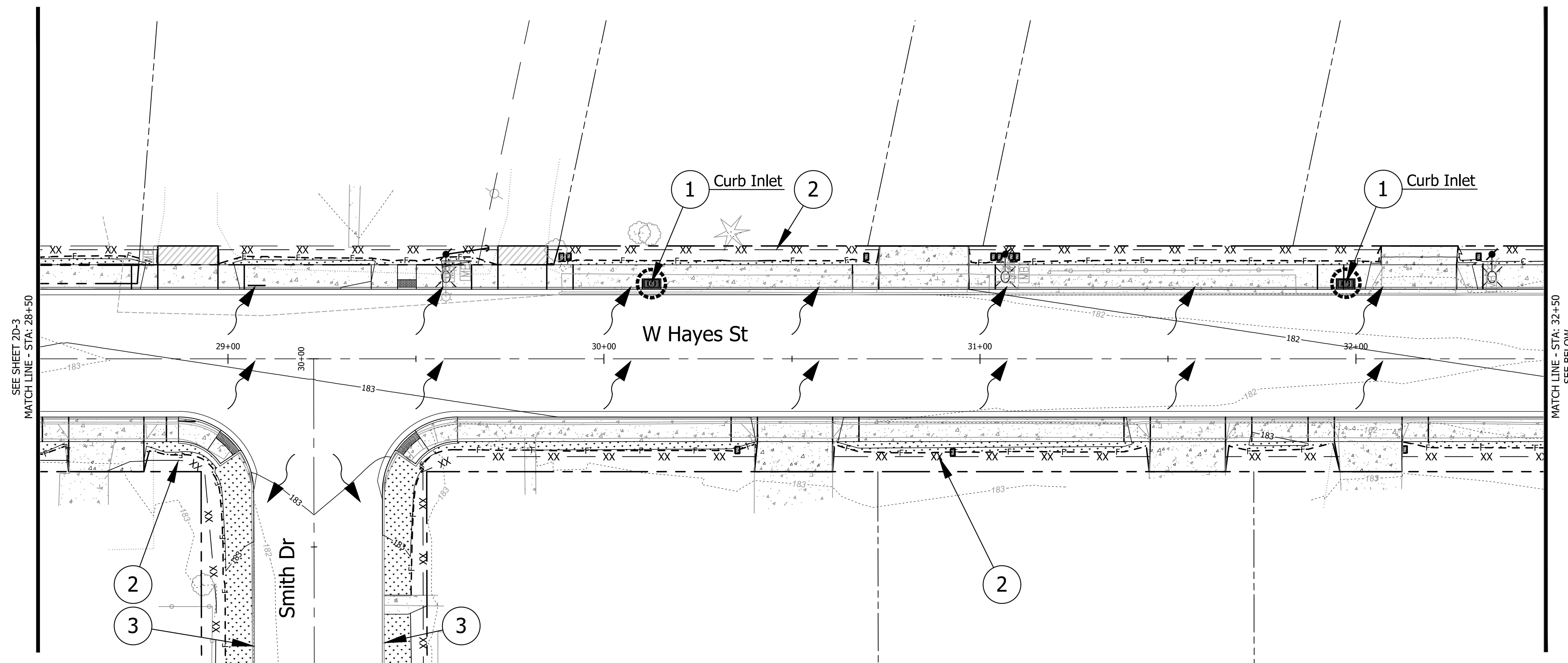

LEGEND

- XX — XX — XX — XX — Sediment Fence
- — — — Existing ROW Line
- — — — Proposed ROW Line
- - - - 250 Existing Major Contours
- - - - 249 Existing Minor Contours
- — — — 250 Proposed Major Contours
- - - - 249 Proposed Minor Contours
- Flow Arrow
- ⊕ ⊕ Extg./Proposed MH
- ⊞ ⊞ Extg./Proposed CB
- ⊘ ⊘ Inlet Protection
- ⊞ Concrete Washout Facility
- ★ ○ Trees to Remain
- ✕ ✕ Trees to Removed

CONSTRUCTION NOTES

- 1 Install Inlet Protection.
(For Details, See Sht. 2D-7)
- 2 Install Sediment Fence.
(For Details, See Sht. 2D-7)
- 3 Install Inlet Protection at Next Nearest Inlet
Inlet Not Shown
(For Details, See Sht. 2D-7)

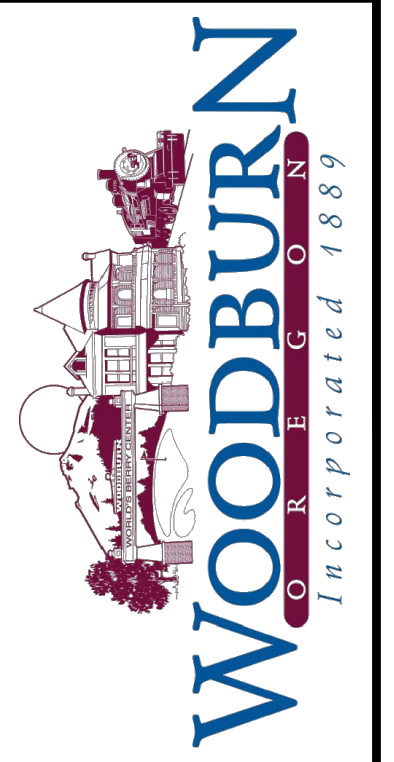
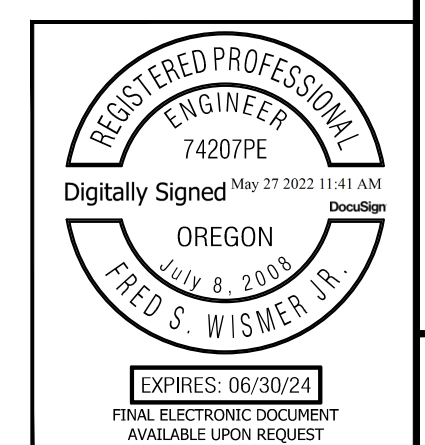
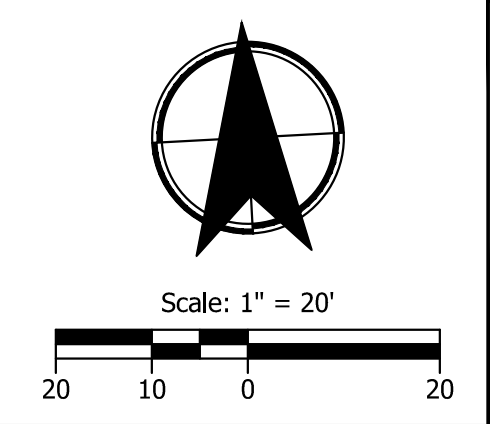

KITTELSON & ASSOCIATES
 851 SW 6TH AVENUE, SUITE 600
 PORTLAND, OR 97204
 P 503.228.5230 F 503.273.8169

DATE	REVISION	APP'D
01/05/25/22	ISSUE FOR CONSTRUCTION	FSW

Submission Date: 03/07/2022
 Drawn: JCB/RMM Designed: NRS/JBK Checked: FSW
 PROJECT NO. 2015-001-20

W. Hayes Street Improvements
 Cascade Avenue to Settlemier Avenue
 GRADING AND EROSION CONTROL PLAN
 SHEET NO. 2D-4

Plot Stamp: 5/27/2022 11:07:32 AM - Fred Wismer
 File: H:\24\24512 - W. Hayes Street\design\CD\CD-Grading and Erosion Control-24512.dwg

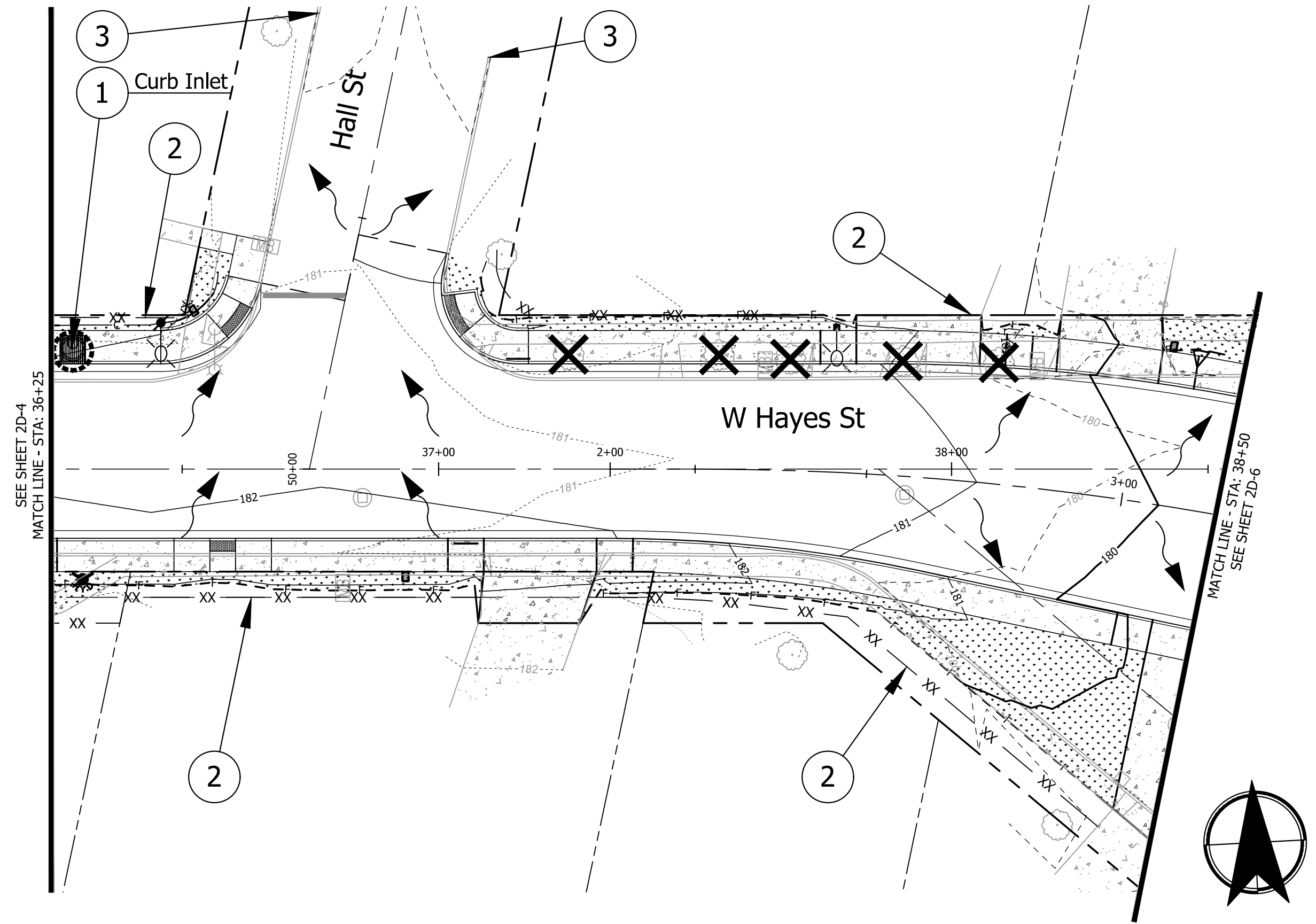

LEGEND

- xx — xx — xx — xx — Sediment Fence
- — — — Existing ROW Line
- — — — Proposed ROW Line
- - - - 250 Existing Major Contours
- · · · 249 Existing Minor Contours
- — — — 250 Proposed Major Contours
- · · · 249 Proposed Minor Contours
- Flow Arrow
- ⊕ ⊕ Extg./Proposed MH
- ▣ ▣ Extg./Proposed CB
- ⊗ ⊗ Inlet Protection
- ◻ Concrete Washout Facility
- ★ ○ Trees to Remain
- ✕ ✕ Trees to Removed

CONSTRUCTION NOTES

- ① Install Inlet Protection.
(For Details, See Sht. 2D-7)
- ② Install Sediment Fence.
(For Details, See Sht. 2D-7)
- ③ Install Inlet Protection at Next Nearest Inlet
Inlet Not Shown
(For Details, See Sht. 2D-7)

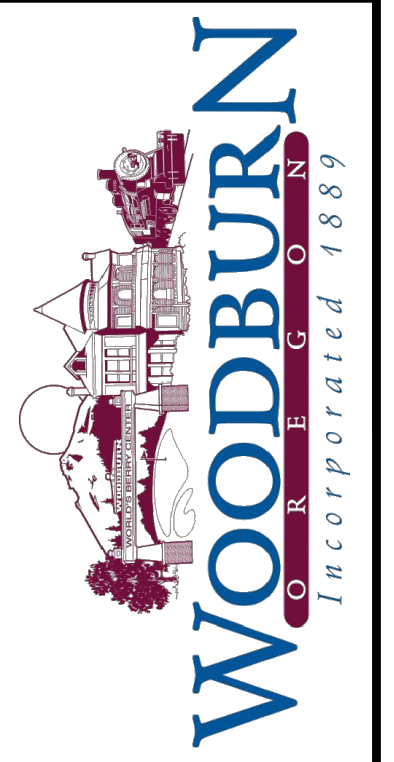
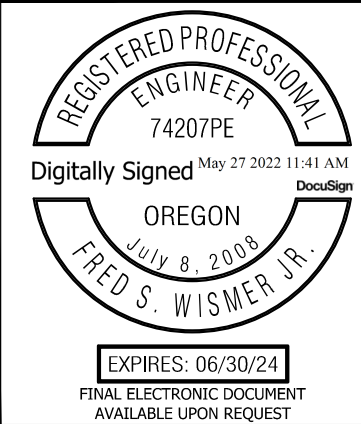
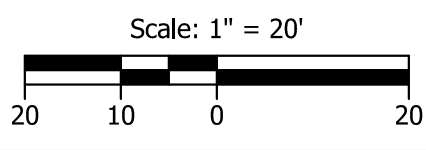

KITTELSON & ASSOCIATES
 851 SW 6TH AVENUE, SUITE 600
 PORTLAND, OR 97204
 P 503.228.5230 F 503.273.8169

REVISION	DATE	APP'D
ISSUE FOR CONSTRUCTION	05/25/22	FSW

Submission Date: 03/07/2022

Drawn: JCB/RMM Designed: NRS/JBK Checked: FSW

PROJECT NO. 2015-001-20

W. Hayes Street Improvements
 Cascade Avenue to Settlemier Avenue
 GRADING AND EROSION CONTROL PLAN

SHEET NO. 2D-5

Plot Stamp: 5/27/2022 11:07:41 AM - Fred Wismer
 File: H:\24\24512 - W. Hayes Street\design\CD\CD-Grading and Erosion Control-24512.dwg

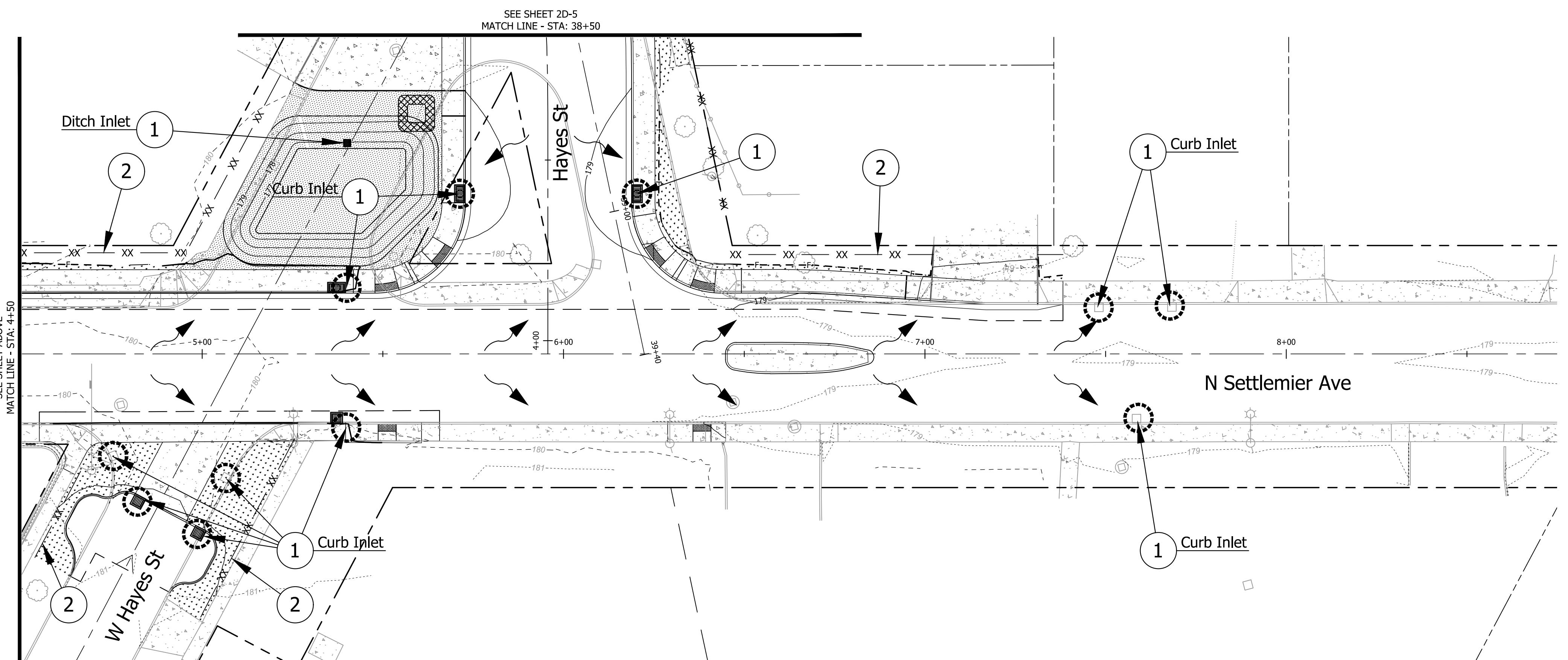
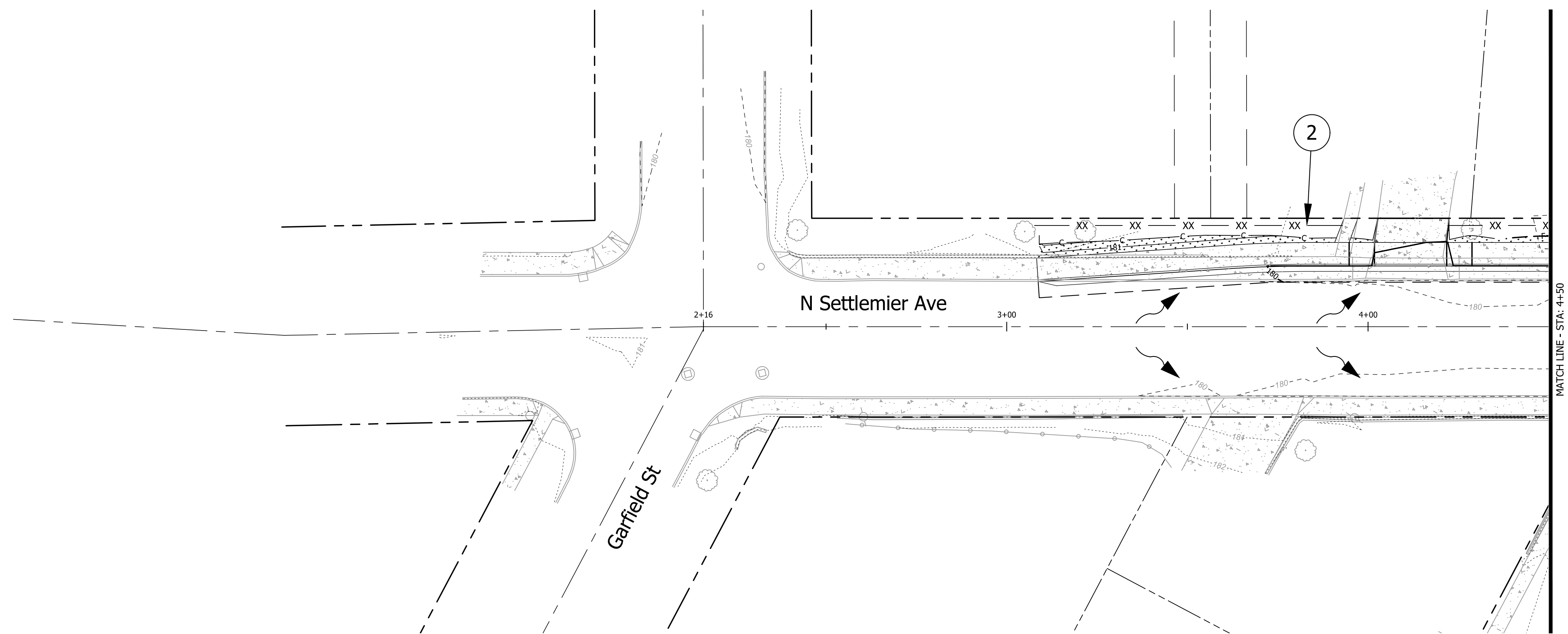

LEGEND

- XX — XX — XX — XX — Sediment Fence
- — — — Existing ROW Line
- — — — Proposed ROW Line
- - - - 250 Existing Major Contours
- · · · 249 Existing Minor Contours
- - - - 250 Proposed Major Contours
- · · · 249 Proposed Minor Contours
- Flow Arrow
- ⊕ ⊕ Extg./Proposed MH
- ⊞ ⊞ Extg./Proposed CB
- ⊘ ⊘ Inlet Protection
- ⊞ Concrete Washout Facility
- ★ ○ Trees to Remain
- ✕ ✕ Trees to Removed

CONSTRUCTION NOTES

- 1 Install Inlet Protection.
(For Details, See Sht. 2D-7)
- 2 Install Sediment Fence.
(For Details, See Sht. 2D-7)
- 3 Install Inlet Protection at Next Nearest Inlet
Inlet Not Shown
(For Details, See Sht. 2D-7)

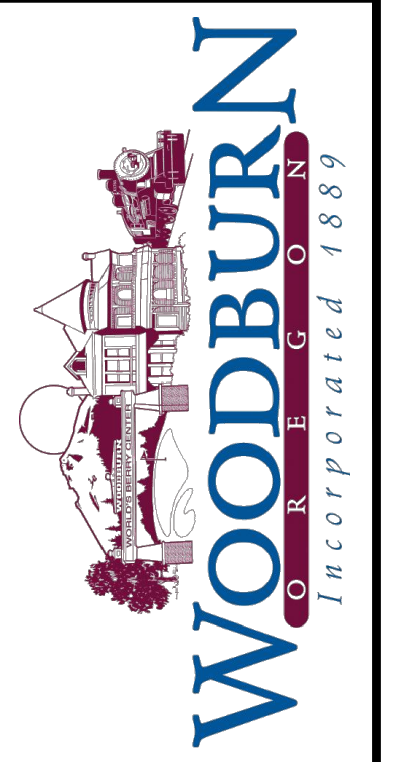
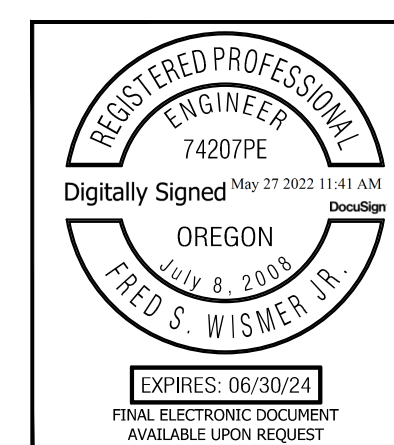
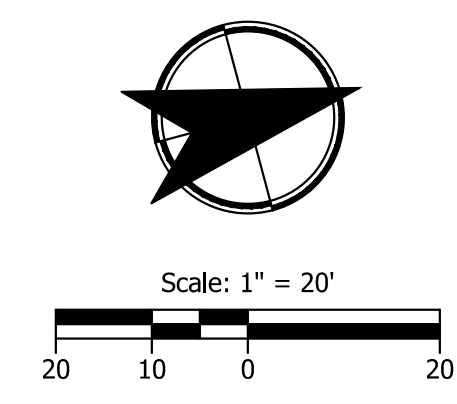

KITTELSON & ASSOCIATES
 851 SW 6TH AVENUE, SUITE 600
 PORTLAND, OR 97204
 P 503.228.5230 F 503.273.8169

DATE	REVISION	APP'D
01/05/25/22	ISSUE FOR CONSTRUCTION	FSW

Submission Date: 03/07/2022
 Drawn: JCB/RMM
 Designed: NRS/JBK
 Checked: FSW
 PROJECT NO. 2015-001-20

W. Hayes Street Improvements
 Cascade Avenue to Settlemier Avenue
 GRADING AND EROSION CONTROL PLAN

SHEET NO. 2D-6

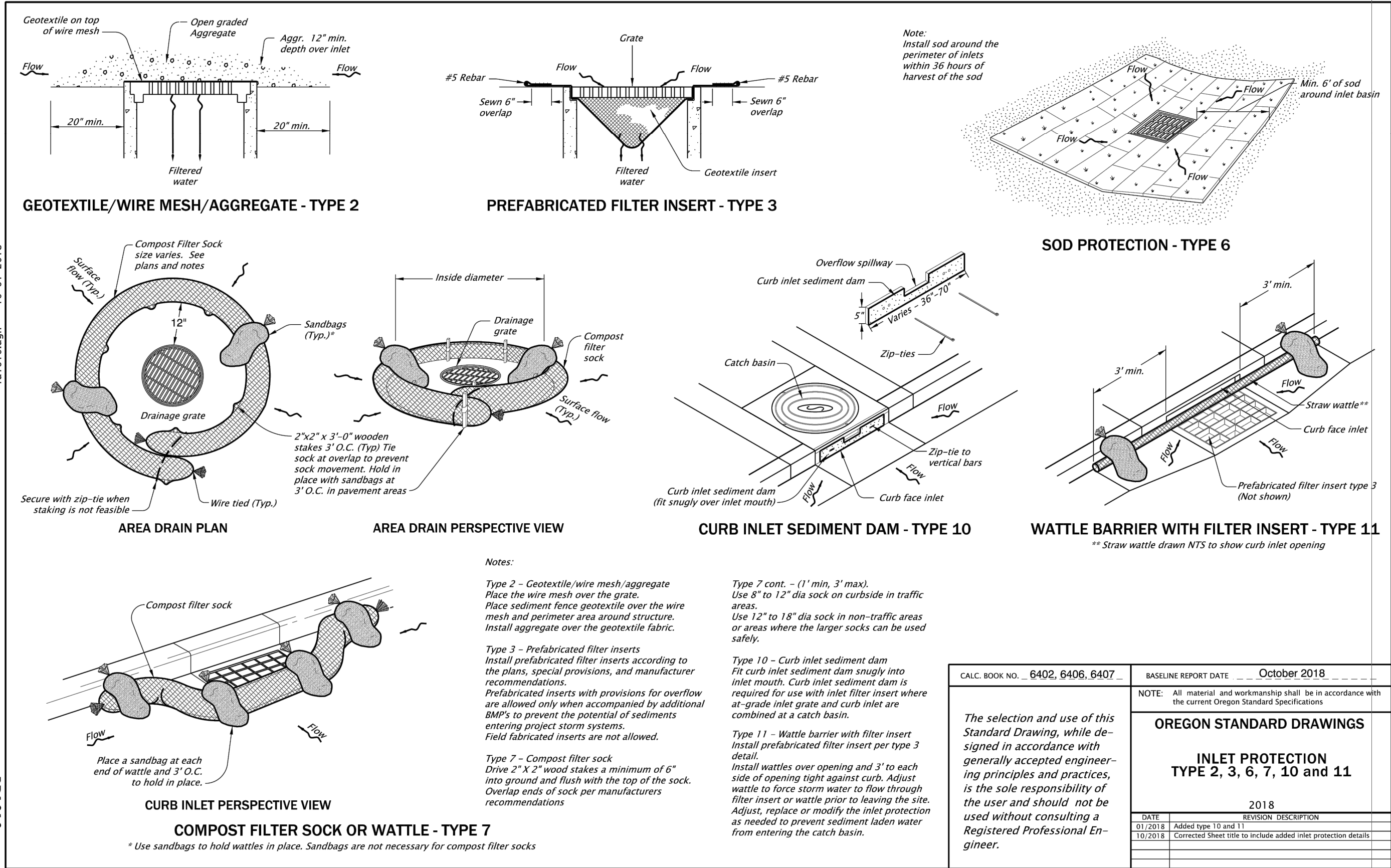

CALC. BOOK NO. 6402, 6406, 6407	BASILINE REPORT DATE October 2018
NOTE: All material and workmanship shall be in accordance with the current Oregon Standard Specifications	
OREGON STANDARD DRAWINGS	
INLET PROTECTION	
TYPE 2, 3, 6, 7, 10 and 11	
2018	
DATE	REVISION DESCRIPTION
10/2018	Added type 10 and 11
10/2018	Corrected Sheet title to include added inlet protection details

Effective Date: June 1, 2020 - November 30, 2020 RD1010

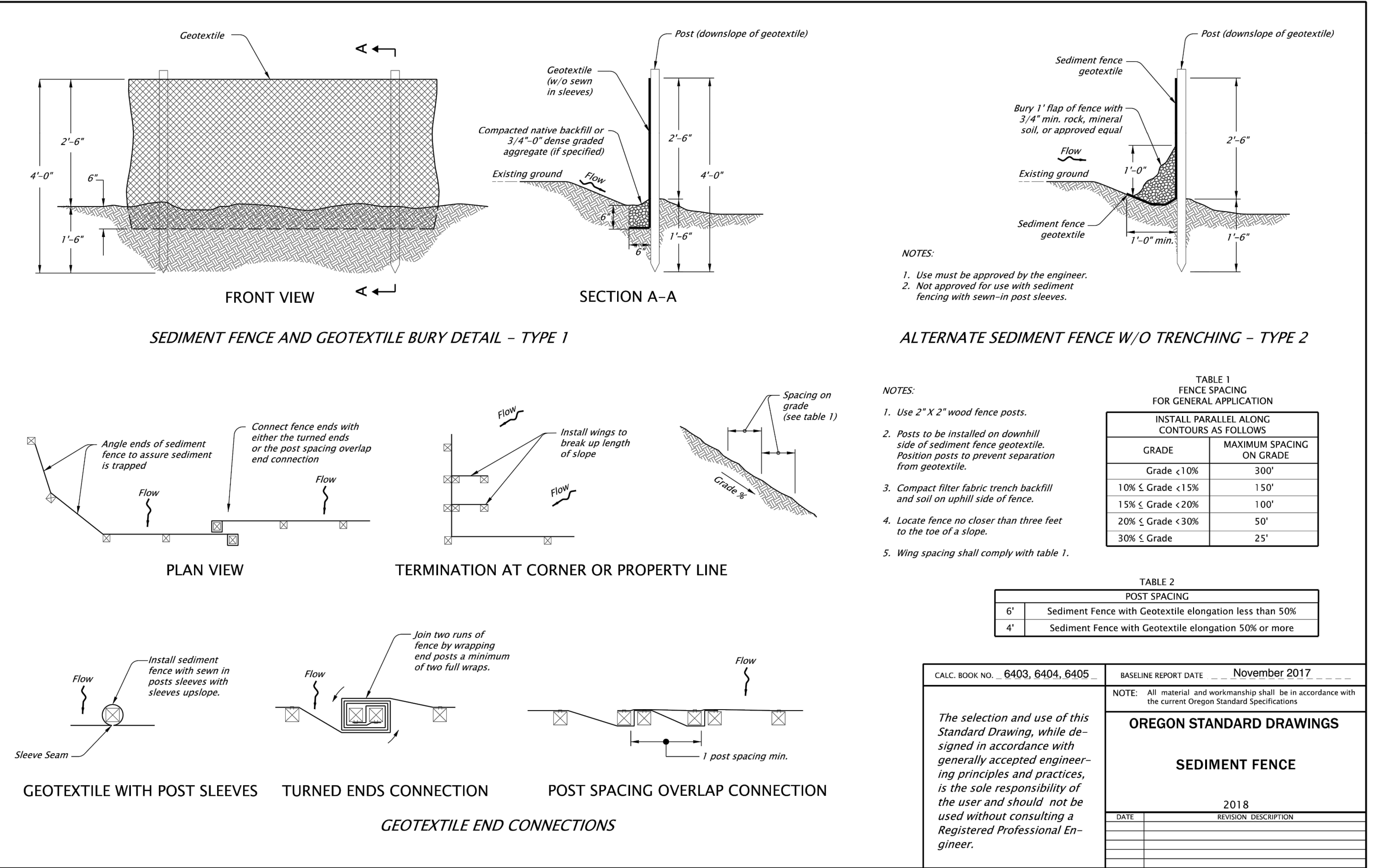

CALC. BOOK NO. 6403, 6404, 6405	BASILINE REPORT DATE November 2017
NOTE: All material and workmanship shall be in accordance with the current Oregon Standard Specifications	
OREGON STANDARD DRAWINGS	
SEDIMENT FENCE	
2018	
DATE	REVISION DESCRIPTION

Effective Date: June 1, 2020 - November 30, 2020 RD1040

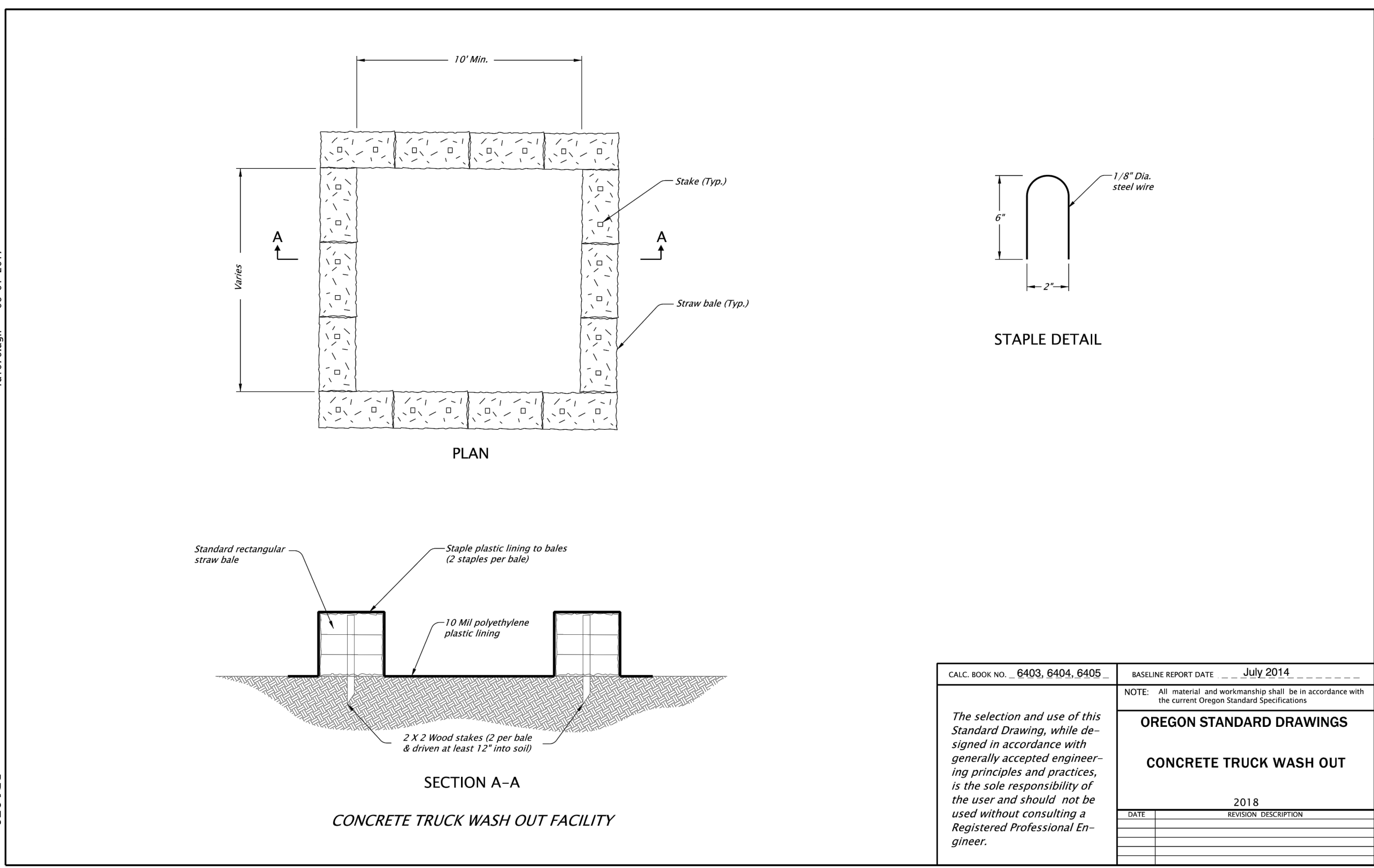

CALC. BOOK NO. 6403, 6404, 6405	BASILINE REPORT DATE July 2014
NOTE: All material and workmanship shall be in accordance with the current Oregon Standard Specifications	
OREGON STANDARD DRAWINGS	
CONCRETE TRUCK WASH OUT	
2018	
DATE	REVISION DESCRIPTION

Effective Date: June 1, 2020 - November 30, 2020 RD1070

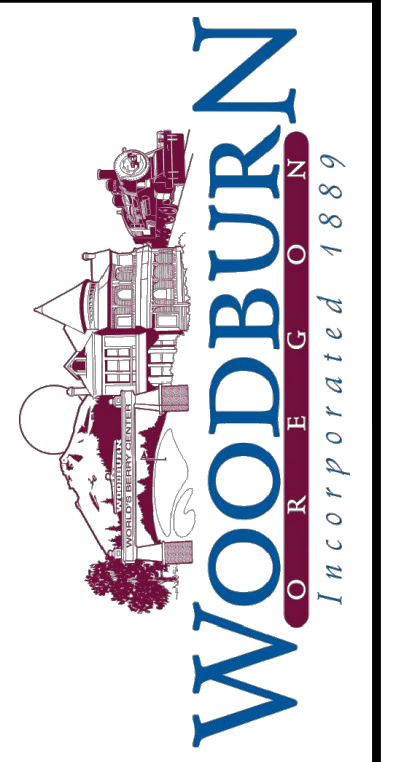

KITTELSON & ASSOCIATES
 851 SW 6TH AVENUE, SUITE 600
 PORTLAND, OR 97204
 P 503.228.5230 F 503.273.8169

0	05/25/22	ISSUE FOR CONSTRUCTION	FSW	APP'D
		REVISION		

Submission Date: 03/07/2022
 Drawn: JCB/RMM Designed: NRS/JBK Checked: FSW
 PROJECT NO. 2015-001-20

W. Hayes Street Improvements
 Cascade Avenue to Settlemier Avenue
 GRADING AND EROSION CONTROL DETAILS
 SHEET NO. 2D-7

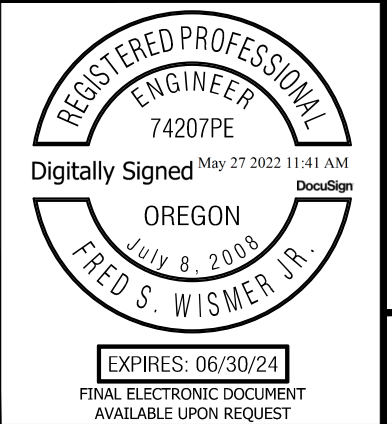

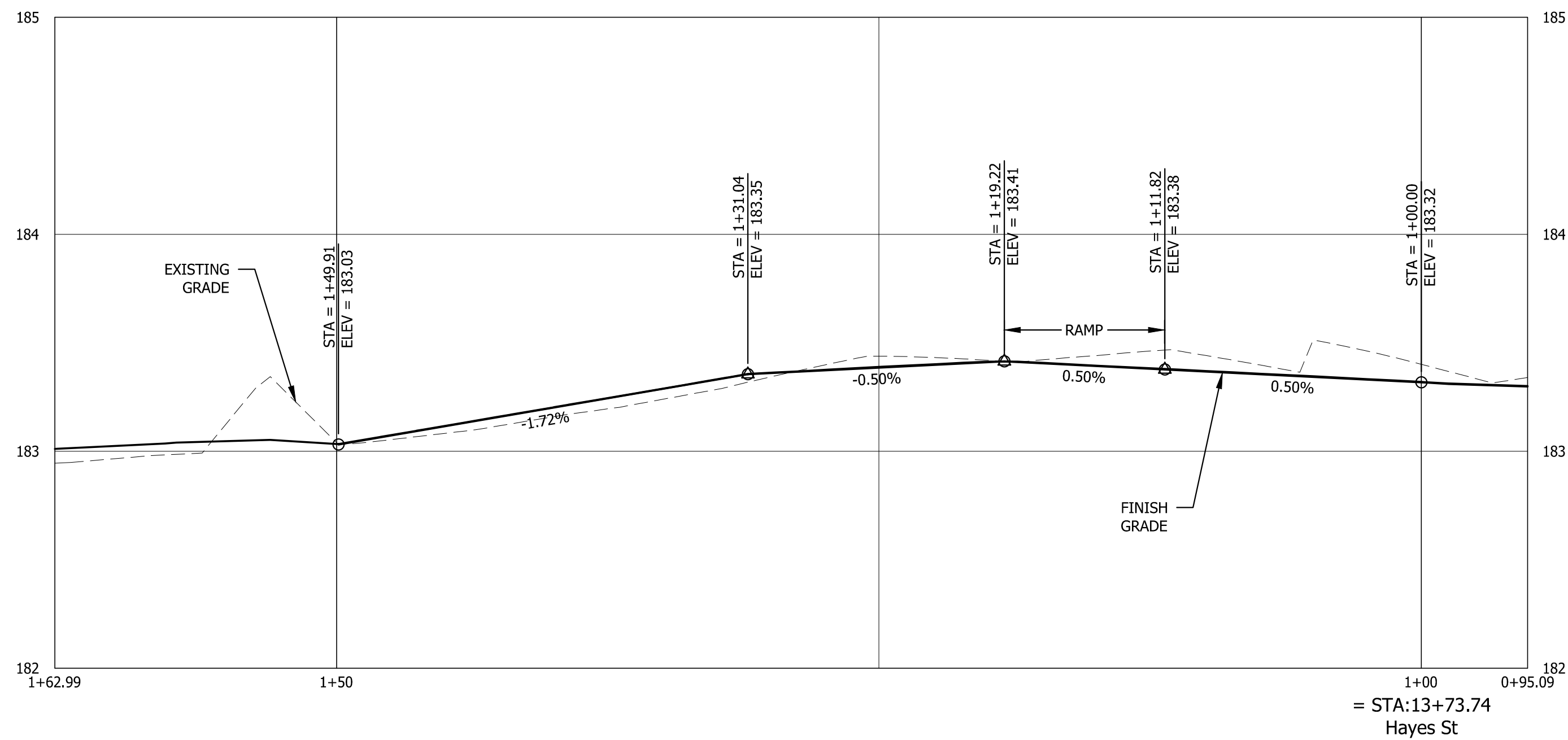

NE Curb Return

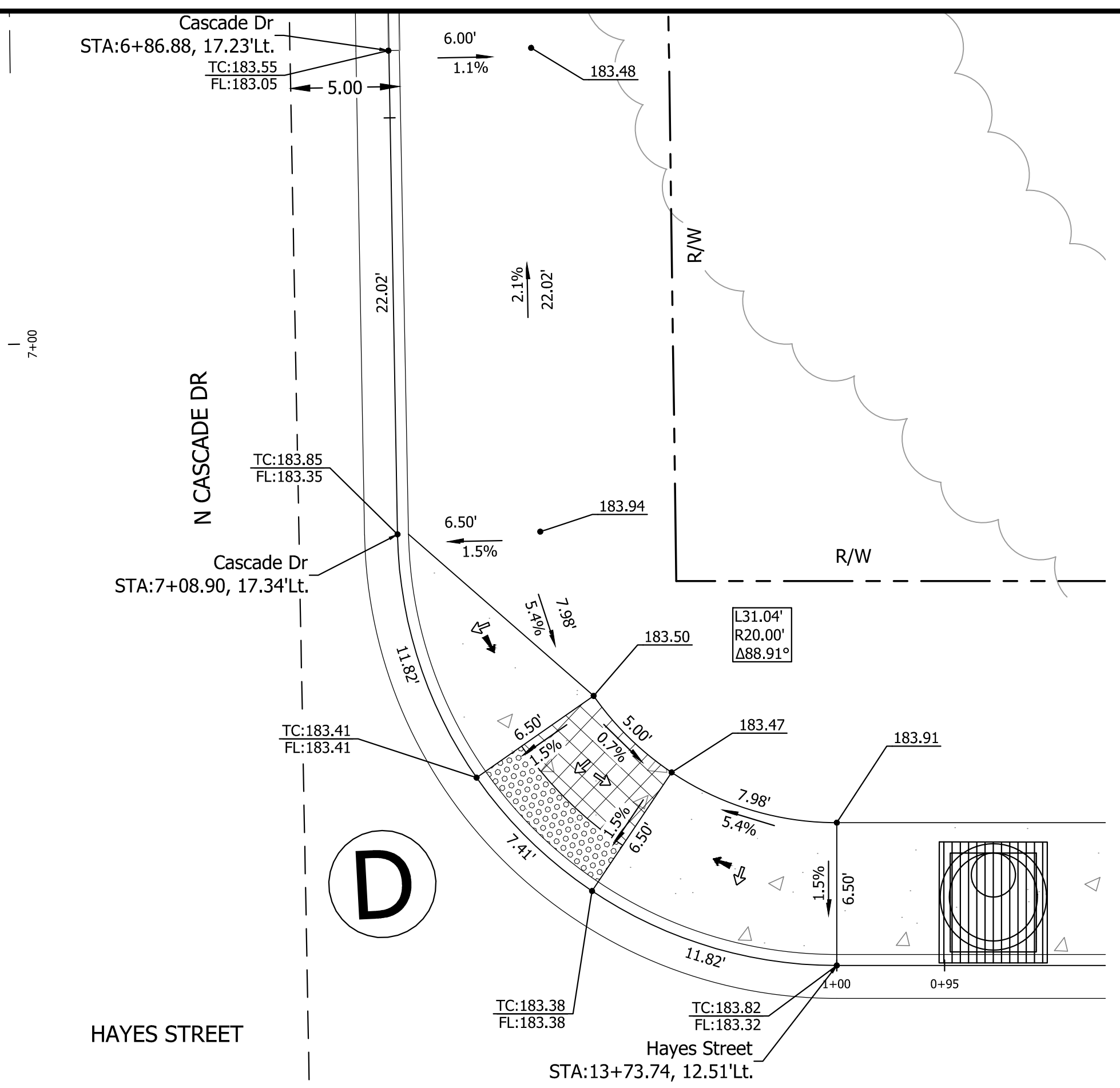

SIDEWALK RAMP GENERAL NOTES

- Contractor shall be responsible for meeting all Americans with disabilities (ADA) requirements as defined by the public rights-of-way accessibility guidelines (PROWAG). Details and dimensions shown are approximate only and intended as a guide for initial layout purposes only and are not complete. Contractor shall take all necessary field measurements and otherwise verify all dimensions to meet ada requirements. Should any error or inconsistency exist the contractor shall not proceed with the work affected until reported to the engineer for clarification or correction.
- Protect freshly poured concrete from vandalism or other damage for a minimum of twenty-four (24) hours or until cured enough to support typical use, whichever is longer. Any concrete damaged by vandalism or other causes shall be replaced at no cost to the city.
- See Standard ODOT Details RD902, RD904, RD906, and RD920 for Curb Ramp Construction on Sheet 2B-6

LEGEND

- Detectable Warning Surface
- Turning Space
- Slope 1.5% (max. 2.0% Finished Surface Slope) (normal Sidewalk Cross Slope)
- Slope 7.5% (max. 8.3% Finished Surface Slope)

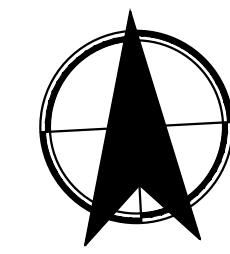

Scale: 1" = 5'

ABBREVIATION

- TC = Top of Curb Elevation
- BC = Bottom of Curb Elevation
- FL = Flow Line
- () = Match Extg. Grade

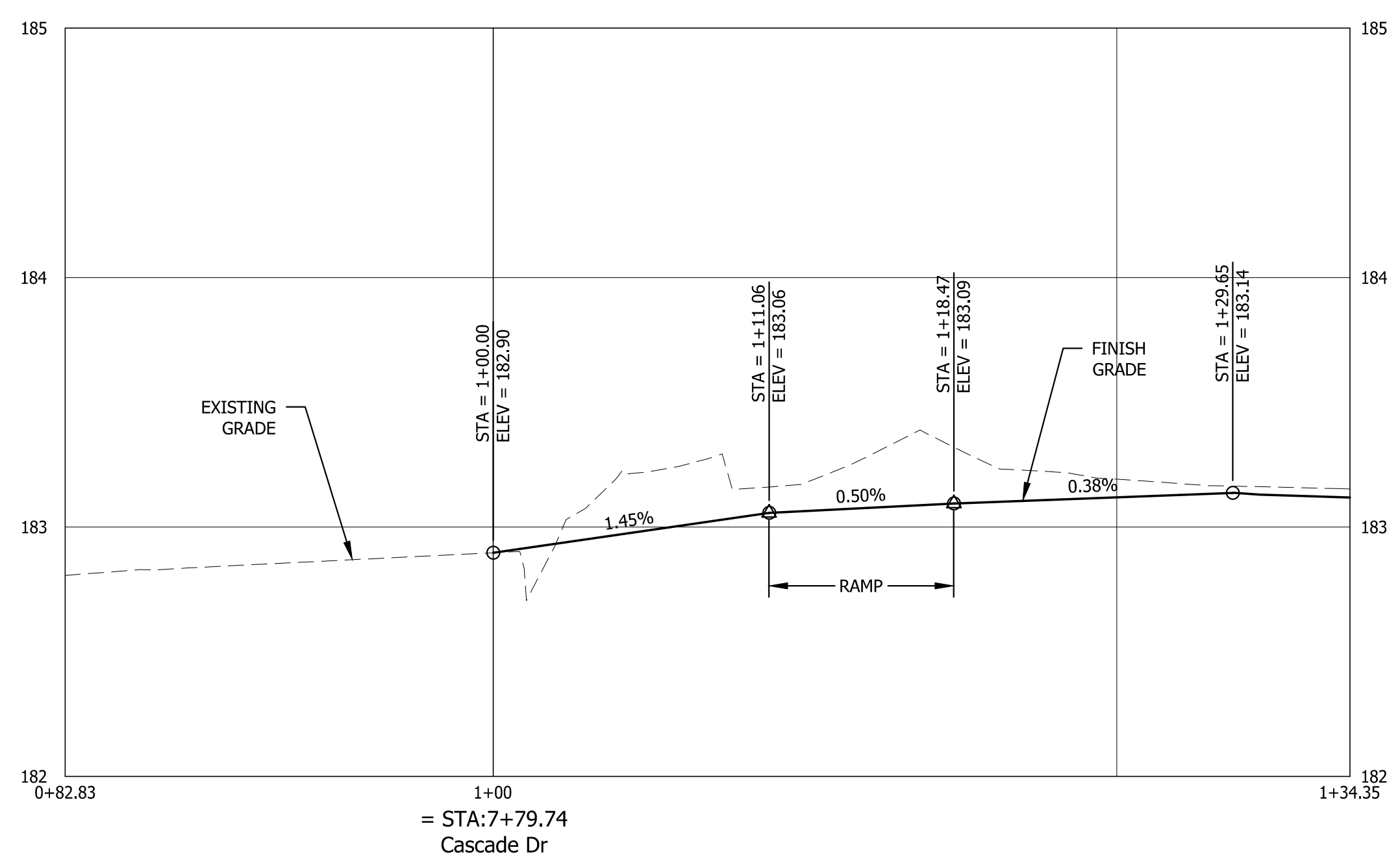

SE Curb Return

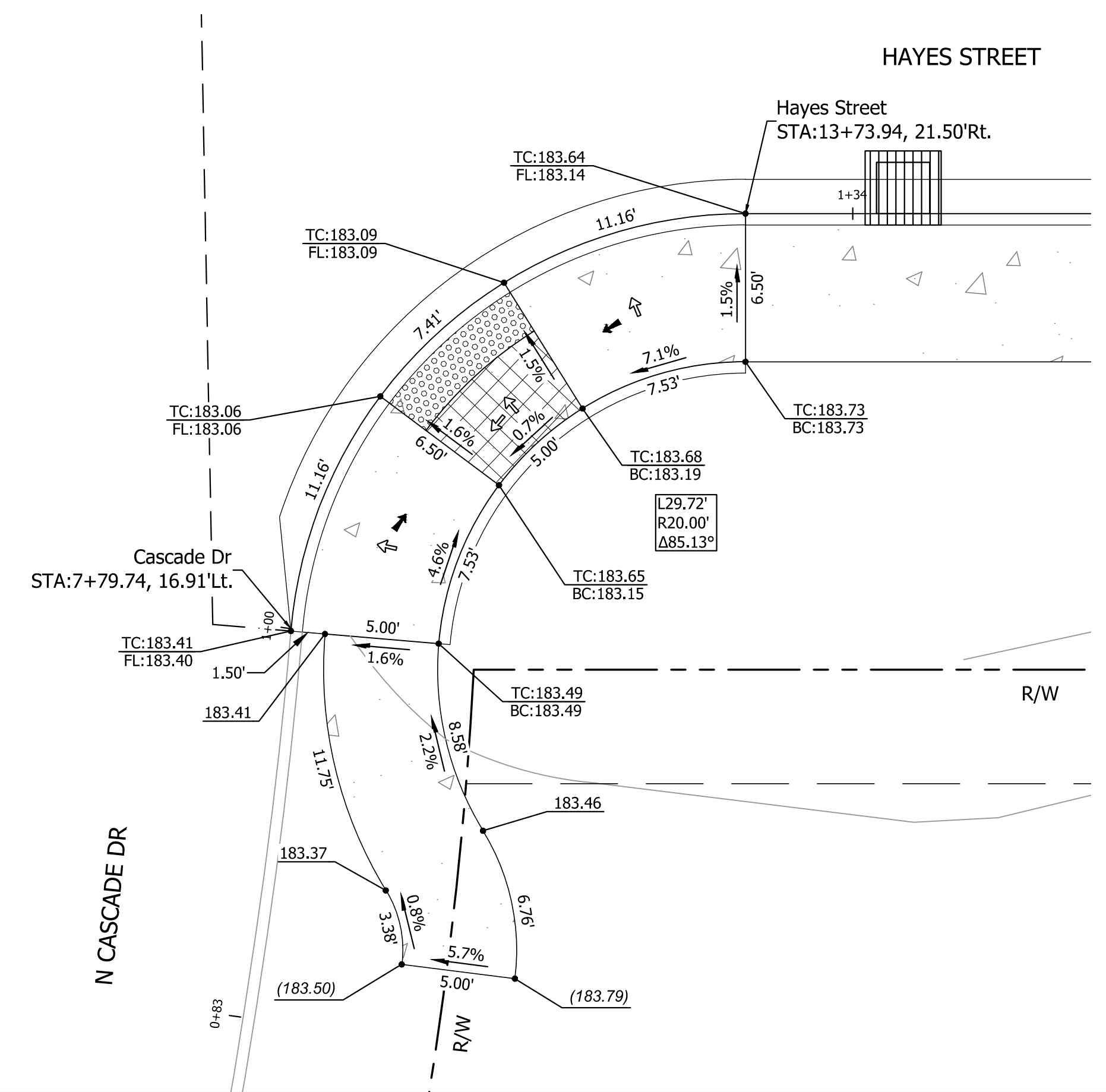

Plot Stamp: 5/27/2022 11:15:46 AM - Fred Wismer
File: H:\24\24512 - W. Hayes Street\design\CD\CD-Detailed-Grading-Plans-24512.dwg

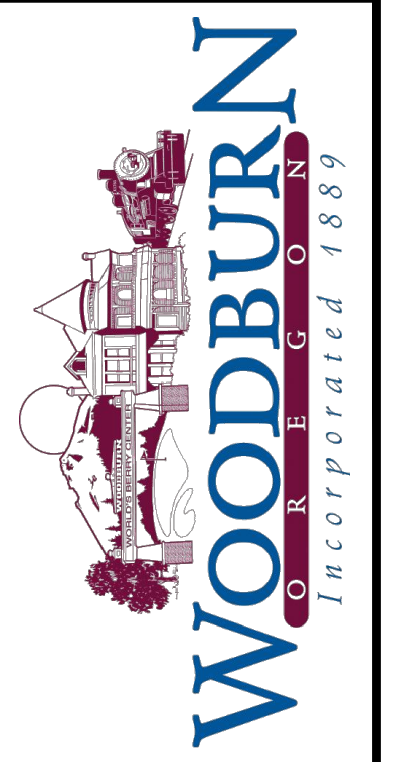

KITTELSON & ASSOCIATES
851 SW 6TH AVENUE, SUITE 600
PORTLAND, OR 97204
P 503.228.5230 F 503.273.8169

NO.	DATE	REVISION	APP'D
0	05/25/22	ISSUE FOR CONSTRUCTION	FSW

Submission Date: 03/07/2022
Drawn: JCB/RMM
Designed: NRS/JBK
Checked: FSW

PROJECT NO. 2015-001-20

W. Hayes Street Improvements
Cascade Avenue to Settlemier Avenue
DETAILED GRADING PLAN
CASCADE DRIVE CURB RAMPS

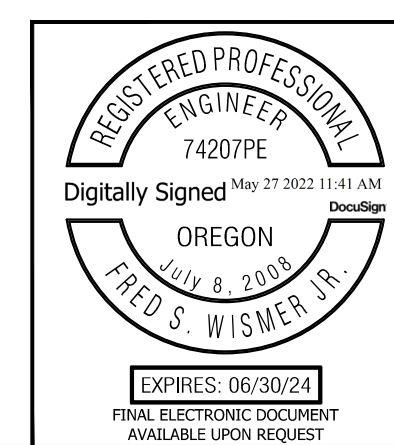

SHEET NO. 2E-1A

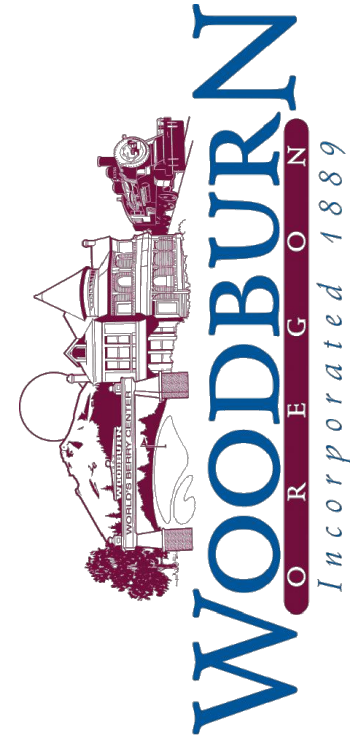

KITTELSON & ASSOCIATES
 851 SW 6TH AVENUE, SUITE 600
 PORTLAND, OR 97204
 P 503.228.5230 F 503.273.8169

NO.	DATE	REVISION	APP'D
0	05/25/22	ISSUE FOR CONSTRUCTION	FSW

Submission Date: 03/07/2022
 Drawn: JCB/RMM Designed: NRS/JBK Checked: FSW

PROJECT NO. 2015-001-20

W. Hayes Street Improvements
 Cascade Avenue to Settlemier Avenue
 INTERSECTION GRADING

SHEET NO. 2E-2

GENERAL NOTES

- Elevations Are Top Of Pavement Finished Grade Unless Otherwise Noted
- Contours Are Top Of Pavement Finished Grade
- Grids Are 5' Spacing
- Extg. Grade Elevations = (XXX.XX)
 Prop. Grade Elevations = XXX.XX

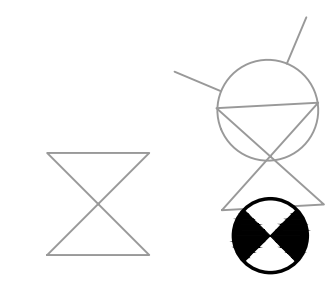
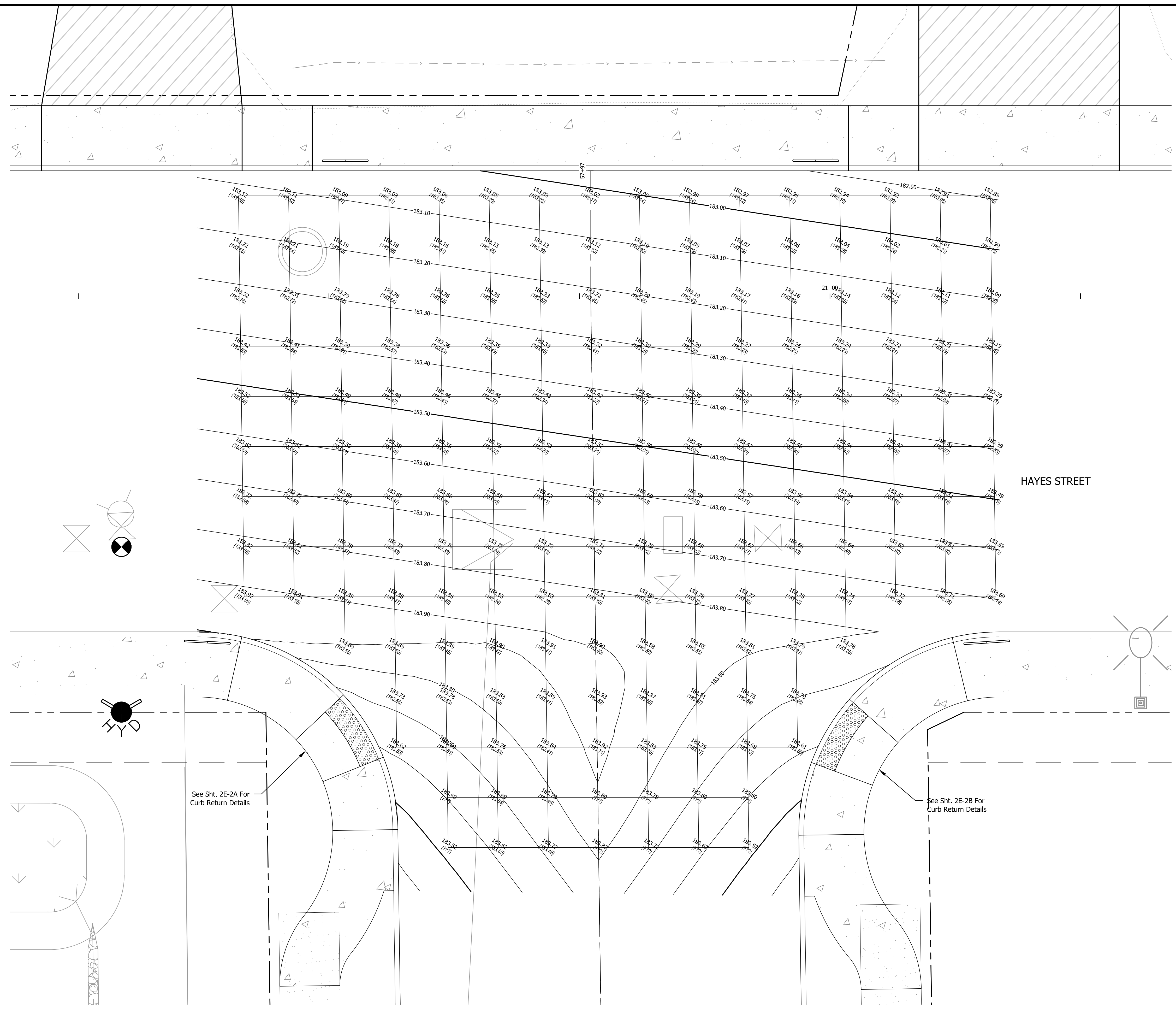
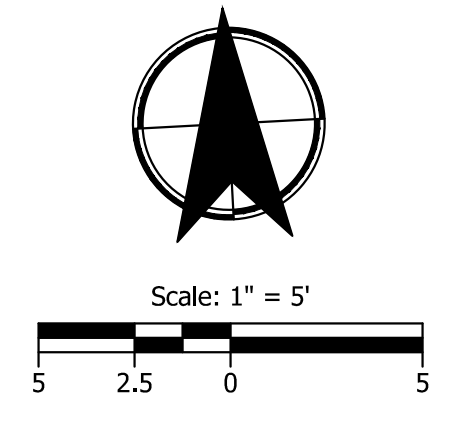

See Sht. 2E-2A For Curb Return Details

See Sht. 2E-2B For Curb Return Details

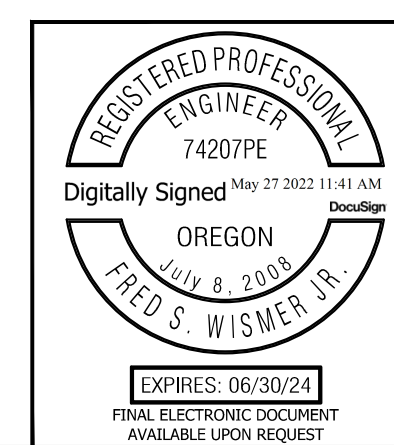

Plot Stamp: 5/27/2022 11:15:53 AM - Fred Wismer
 File: H:\24\24512 - W. Hayes Street\design\CD\CD-Intersection-Grading-Plans-24512.dwg

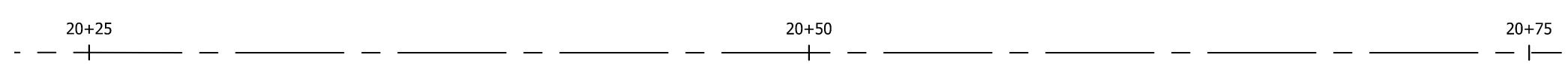

HAYES STREET

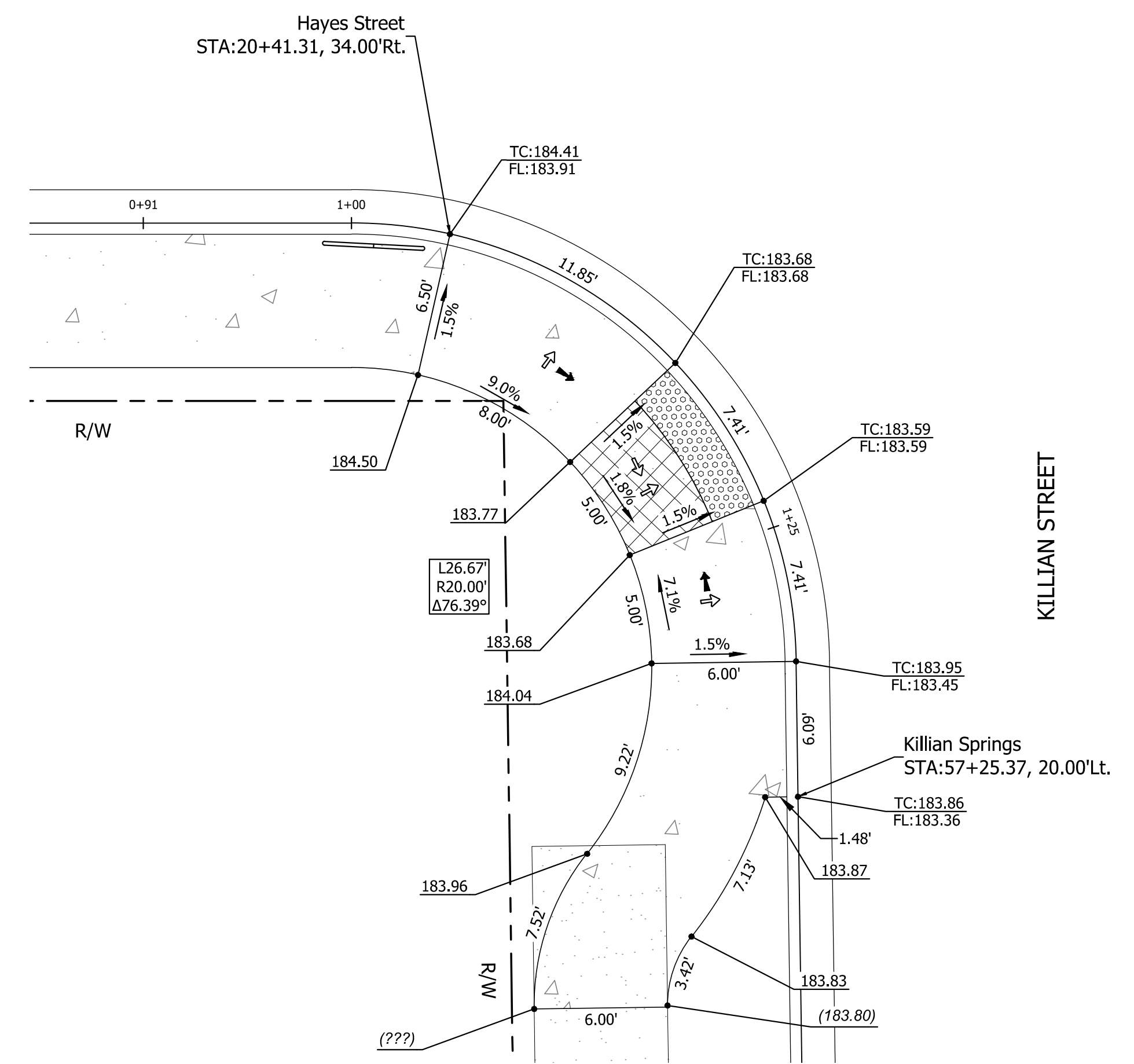

SW Curb Return

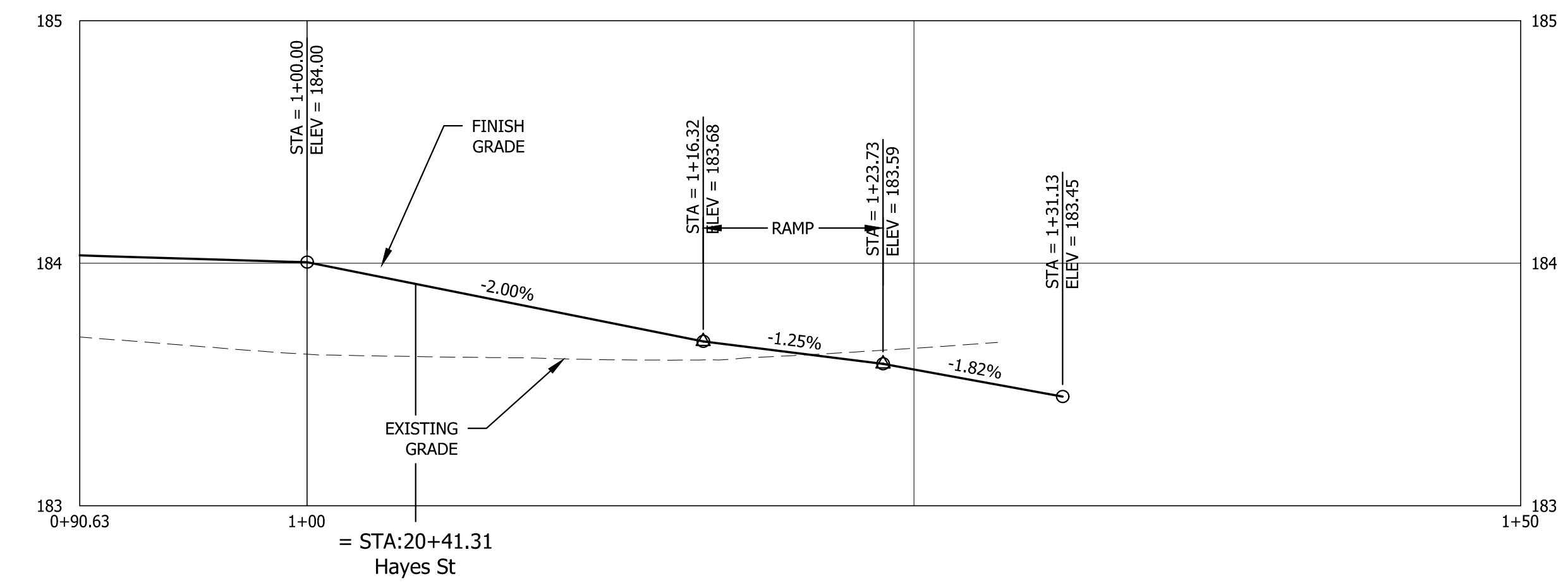

SIDEWALK RAMP GENERAL NOTES

- Contractor shall be responsible for meeting all Americans with Disabilities Act (ADA) requirements as defined by the public rights-of-way accessibility guidelines (PROWAG). Details and dimensions shown are approximate only and intended as a guide for initial layout purposes only and are not complete. Contractor shall take all necessary field measurements and otherwise verify all dimensions to meet ADA requirements. Should any error or inconsistency exist the contractor shall not proceed with the work affected until reported to the engineer for clarification or correction.
- Protect freshly poured concrete from vandalism or other damage for a minimum of twenty-four (24) hours or until cured enough to support typical use, whichever is longer. Any concrete damaged by vandalism or other causes shall be replaced at no cost to the city.
- See Standard ODOT Details RD902, RD904, RD906, and RD920 for Curb Ramp Construction on Sheet 2B-6

LEGEND

- Detectable Warning Surface
- Turning Space
- Slope 1.5% (max. 2.0% Finished Surface Slope) (normal Sidewalk Cross Slope)
- Slope 7.5% (max. 8.3% Finished Surface Slope)

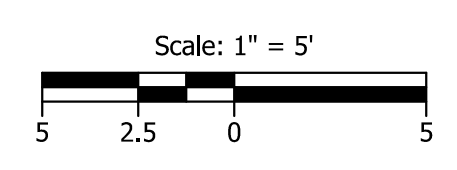
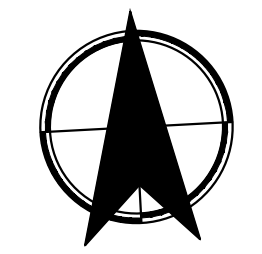

ABBREVIATION

- TC = Top of Curb Elevation
- BC = Bottom of Curb Elevation
- FL = Flow Line
- () = Match Extg. Grade

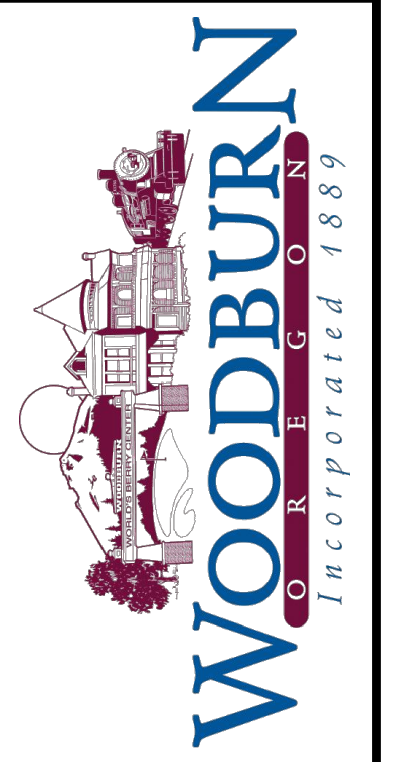

KITTELSON & ASSOCIATES
 851 SW 6TH AVENUE, SUITE 600
 PORTLAND, OR 97204
 P 503.228.5230 F 503.273.8169

REVISION	DATE	BY	APP'D
0	05/25/22	FSW	APP'D

Submission Date: 03/07/2022
 Drawn: JCB/RMM
 Designed: NRS/JBK
 Checked: FSW

PROJECT NO. 2015-001-20

W. Hayes Street Improvements
 Cascade Avenue to Settlemier Avenue
 DETAILED GRADING PLAN
 CURB RAMPS

SHEET NO. 2E-2A

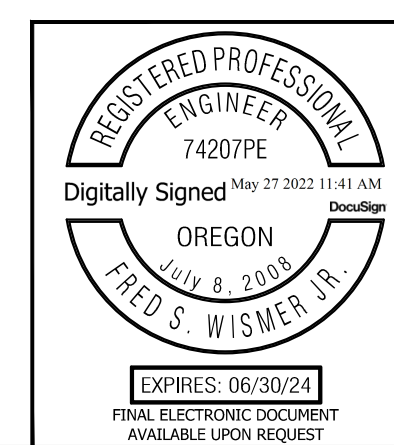

Plot Stamp: 5/27/2022 11:16:26 AM - Fred Wismer
 File: H:\24\24512 - W. Hayes Street\design_CD\CD-Detailed-Grading-Plans-24512.dwg

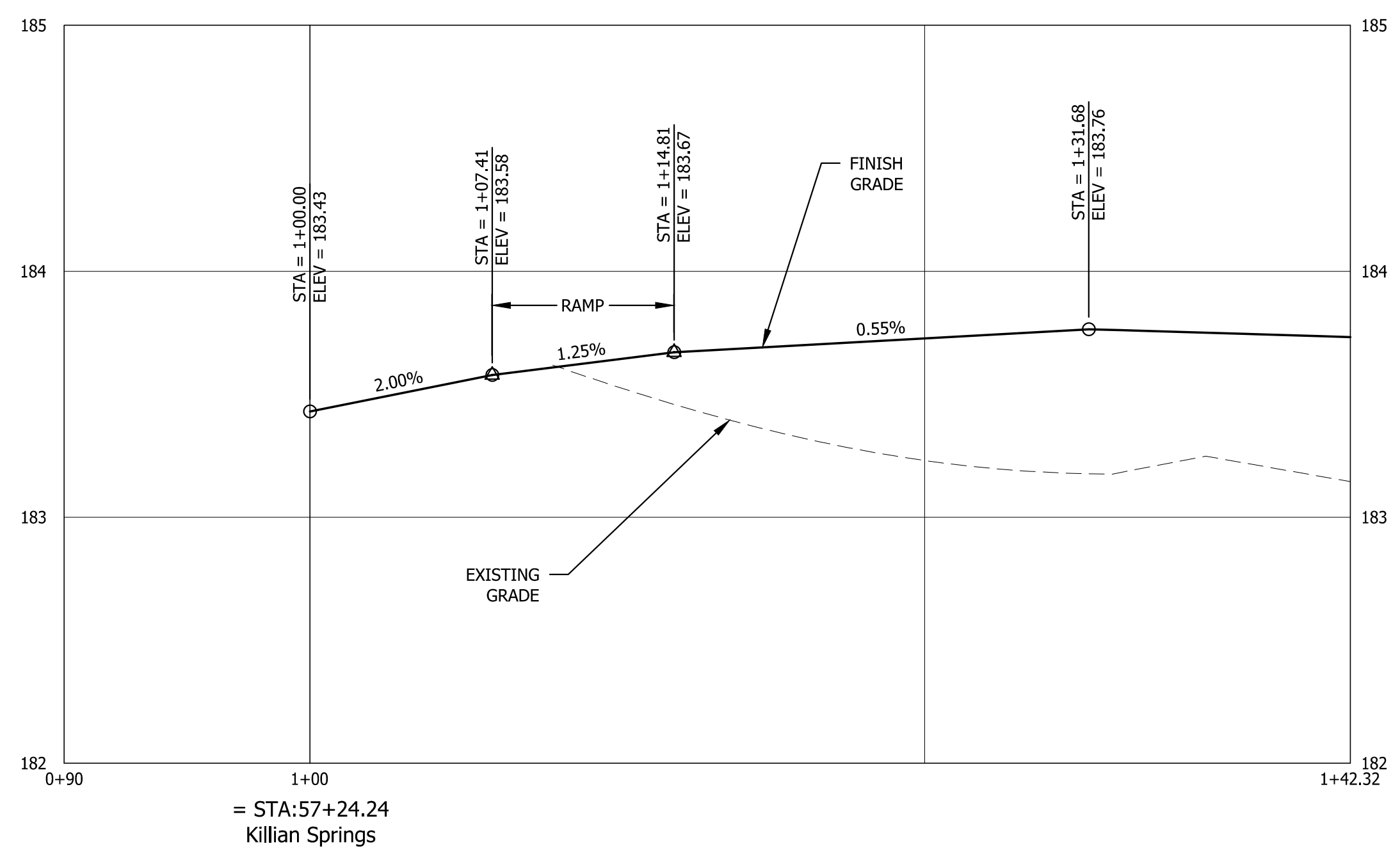

SE Curb Return

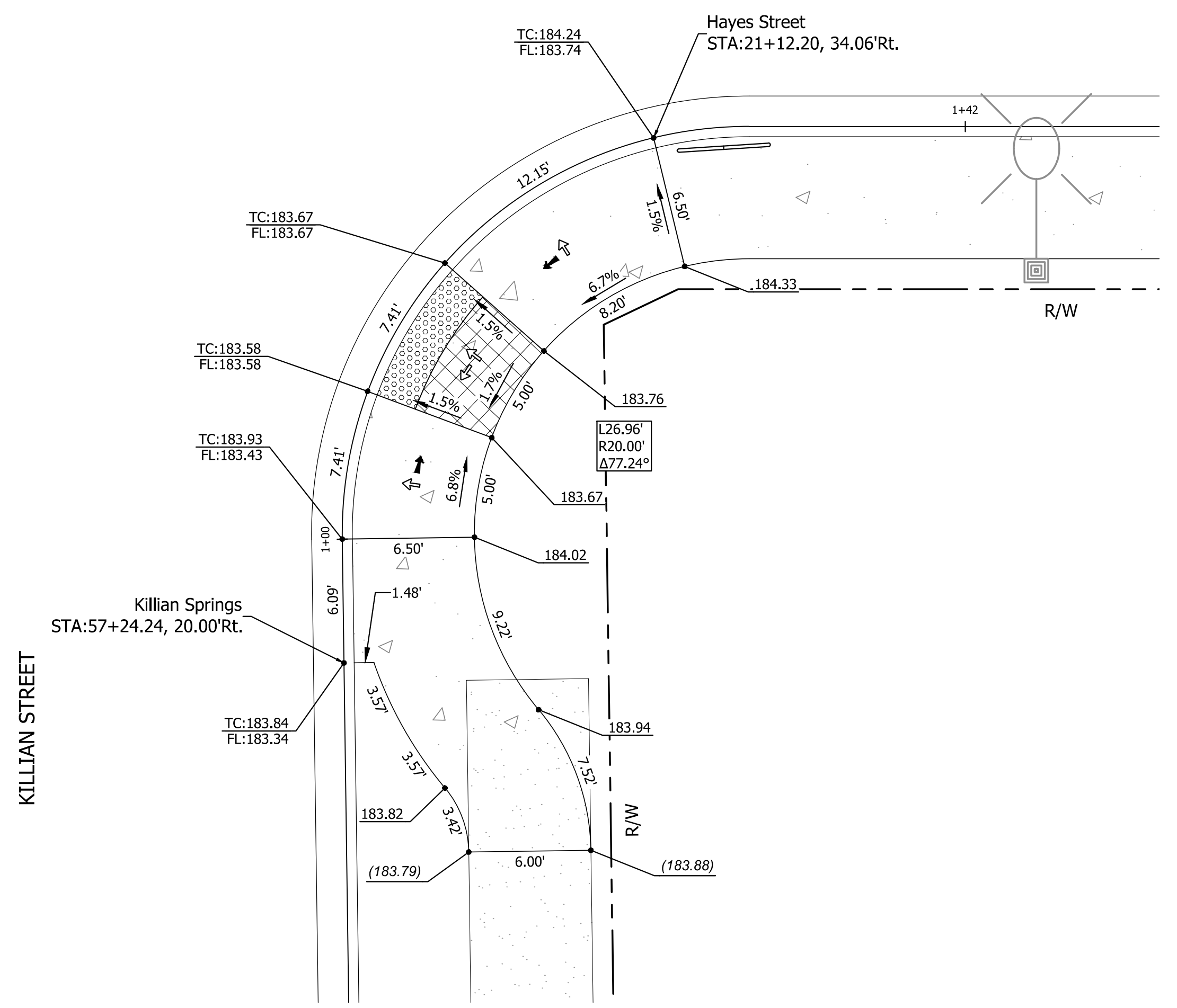

SIDEWALK RAMP GENERAL NOTES

- Contractor shall be responsible for meeting all Americans with disabilities (ADA) requirements as defined by the public rights-of-way accessibility guidelines (PROWAG). Details and dimensions shown are approximate only and intended as a guide for initial layout purposes only and are not complete. Contractor shall take all necessary field measurements and otherwise verify all dimensions to meet ADA requirements. Should any error or inconsistency exist the contractor shall not proceed with the work affected until reported to the engineer for clarification or correction.
- Protect freshly poured concrete from vandalism or other damage for a minimum of twenty-four (24) hours or until cured enough to support typical use, whichever is longer. Any concrete damaged by vandalism or other causes shall be replaced at no cost to the city.
- See Standard ODOT Details RD902, RD904, RD906, and RD920 for Curb Ramp Construction on Sheet 2B-6

LEGEND

- Detectable Warning Surface
- Turning Space
- Slope 1.5%, (max. 2.0% Finished Surface Slope) (normal Sidewalk Cross Slope)
- Slope 7.5%, (max. 8.3% Finished Surface Slope)

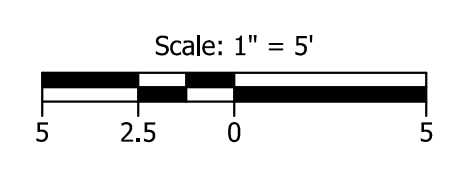
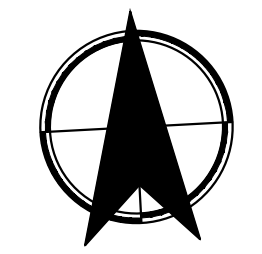

ABBREVIATION

- TC = Top of Curb Elevation
- BC = Bottom of Curb Elevation
- FL = Flow Line
- () = Match Extg. Grade

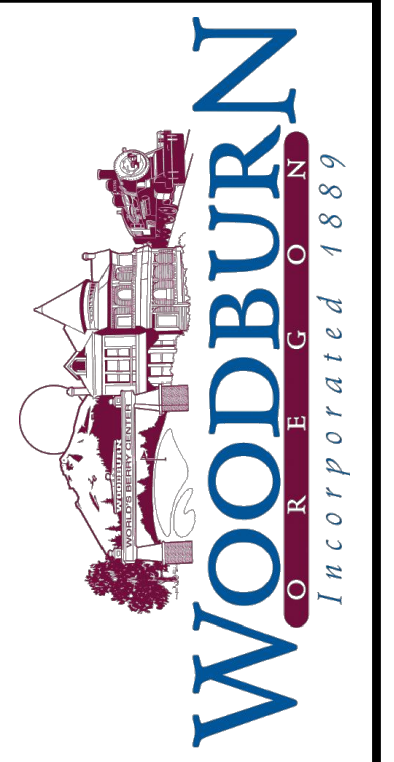

KITTELSON & ASSOCIATES
 851 SW 6TH AVENUE, SUITE 600
 PORTLAND, OR 97204
 P 503.228.5230 F 503.273.8169

DATE	REVISION	APP'D
05/25/22	ISSUE FOR CONSTRUCTION	FSW

Submission Date: 03/07/2022
 Drawn: JCB/RMM
 Designed: NRS/JBK
 Checked: FSW

PROJECT NO. 2015-001-20

W. Hayes Street Improvements
 Cascade Avenue to Settlemier Avenue
 DETAILED GRADING PLAN
 CURB RAMPS



SHEET NO. 2E-2B

Plot Stamp: 5/27/2022 11:16:34 AM - Fred Wismer
 File: H:\24\24512 - W. Hayes Street\design\CD\CD-Intersection-Grading-Plans-24512.dwg

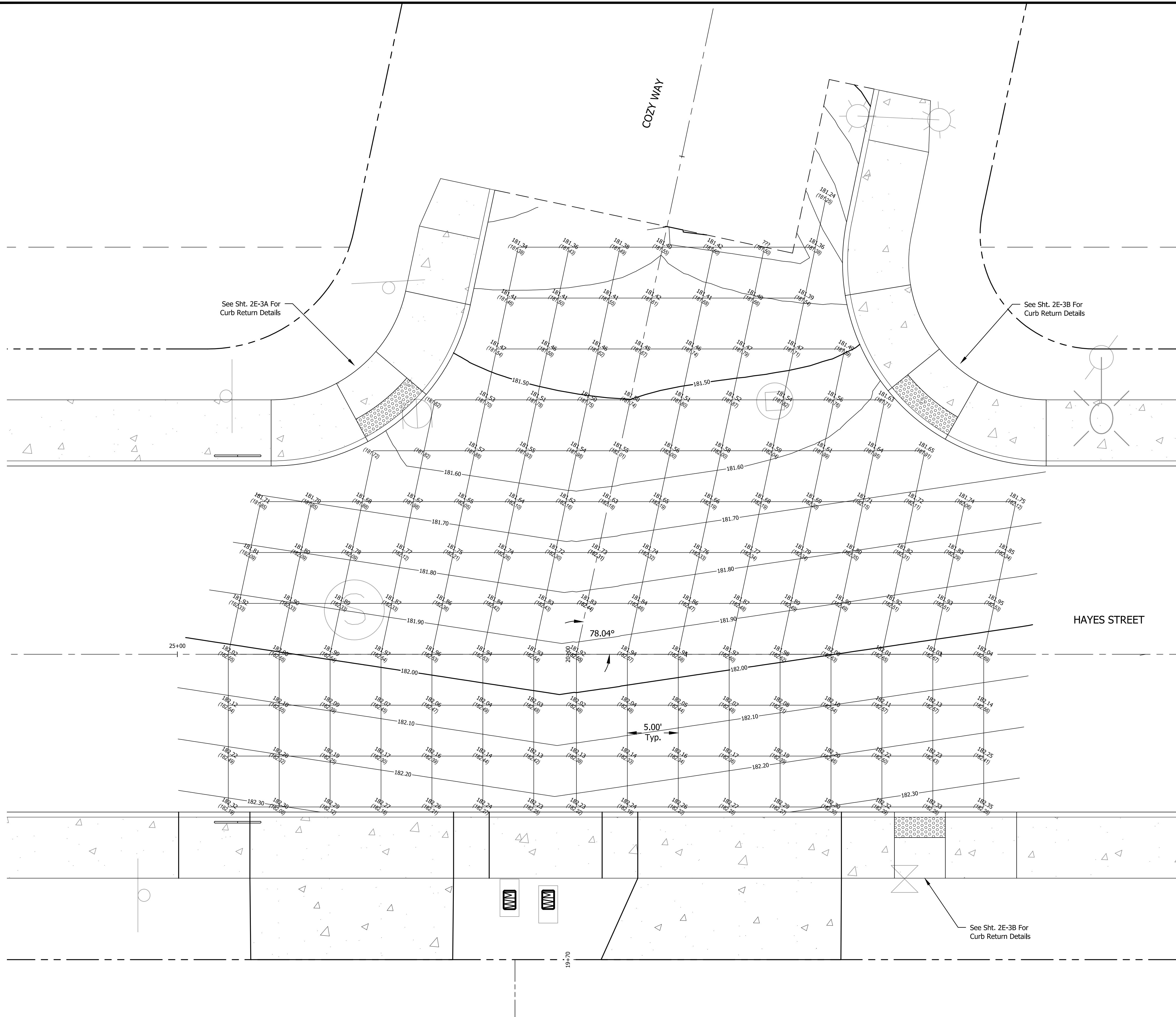

- GENERAL NOTES**
- Elevations Are Top Of Pavement Finished Grade Unless Otherwise Noted
 - Contours Are Top Of Pavement Finished Grade
 - Grids Are 5' Spacing
 - Extg. Grade Elevations = (XXX.XX)
 Prop. Grade Elevations = XXX.XX

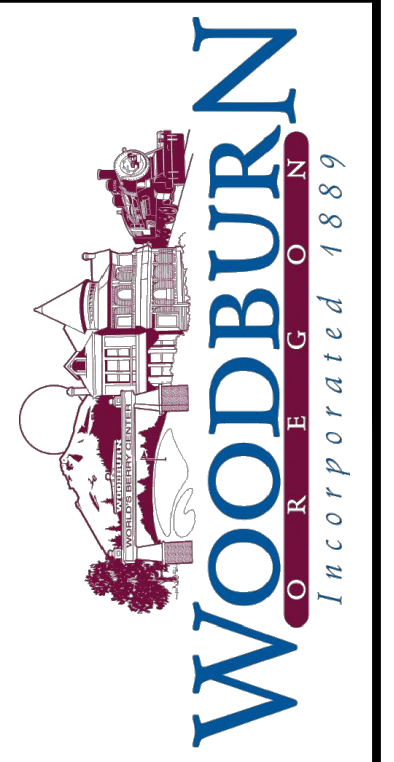
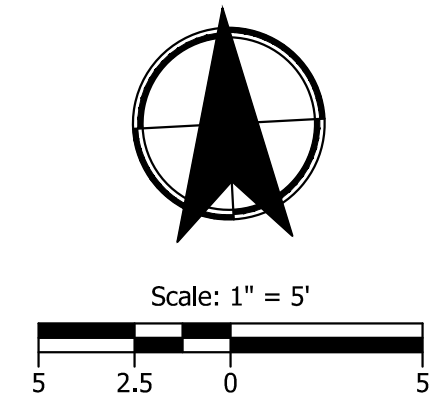

KITTELSON & ASSOCIATES
 851 SW 6TH AVENUE, SUITE 600
 PORTLAND, OR 97204
 P 503.228.5230 F 503.273.8169

NO.	DATE	REVISION	APP'D
0	05/25/22	ISSUE FOR CONSTRUCTION	FSW

Submission Date: 03/07/2022
 Drawn: JCB/RMM Designed: NRS/JBK Checked: FSW

PROJECT NO. 2015-001-20
W. Hayes Street Improvements
 Cascade Avenue to Settlemier Avenue
 INTERSECTION GRADING PLAN
 COZY WAY
 SHEET NO. 2E-3

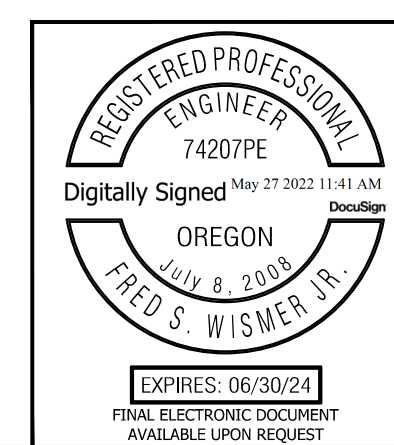

Plot Stamp: 5/27/2022 11:16:51 AM - Fred Wismer
 File: H:\24\24512 - W. Hayes Street\design\CD\CD-Detailed-Grading-Plans-24512.dwg

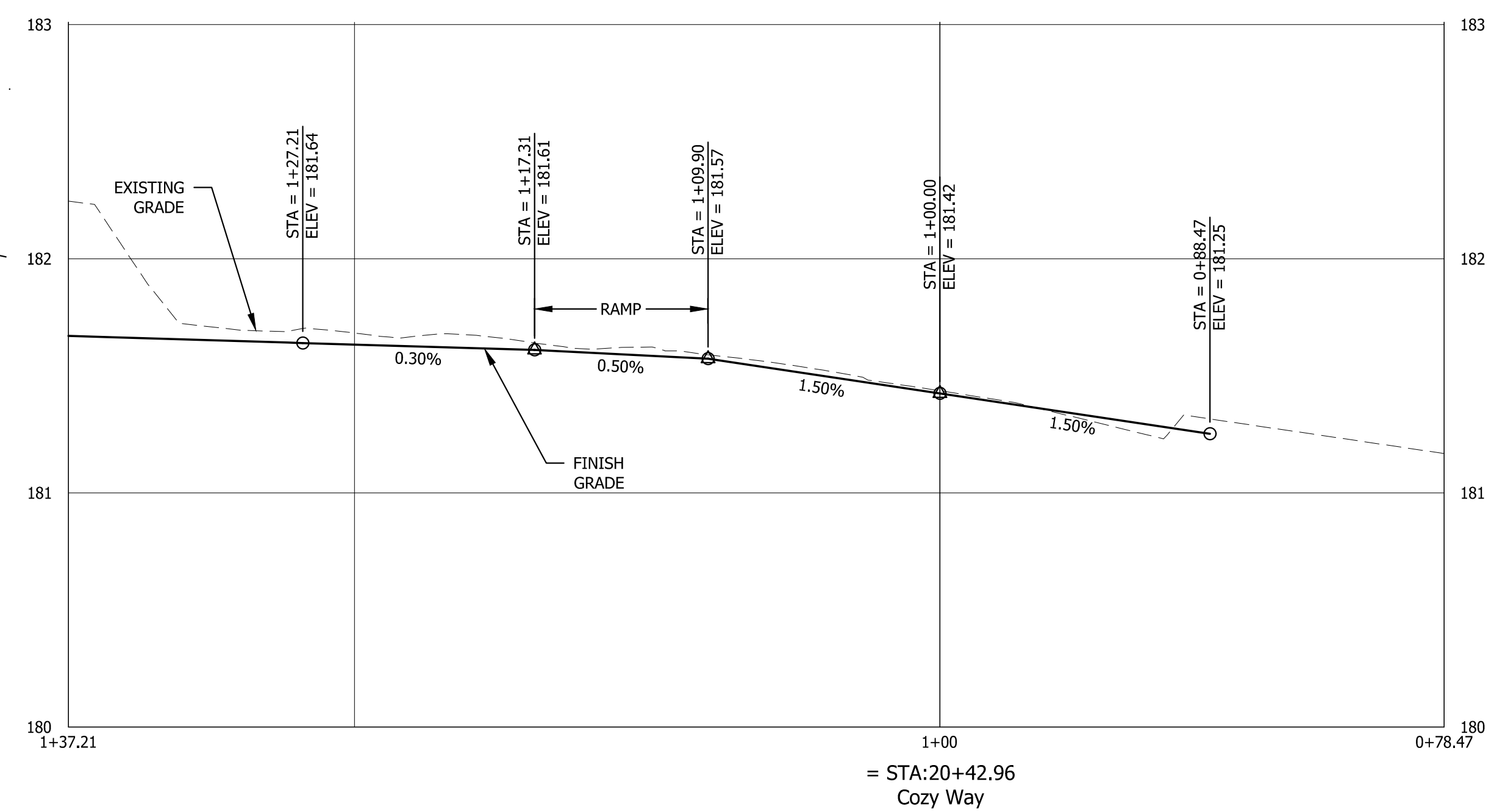
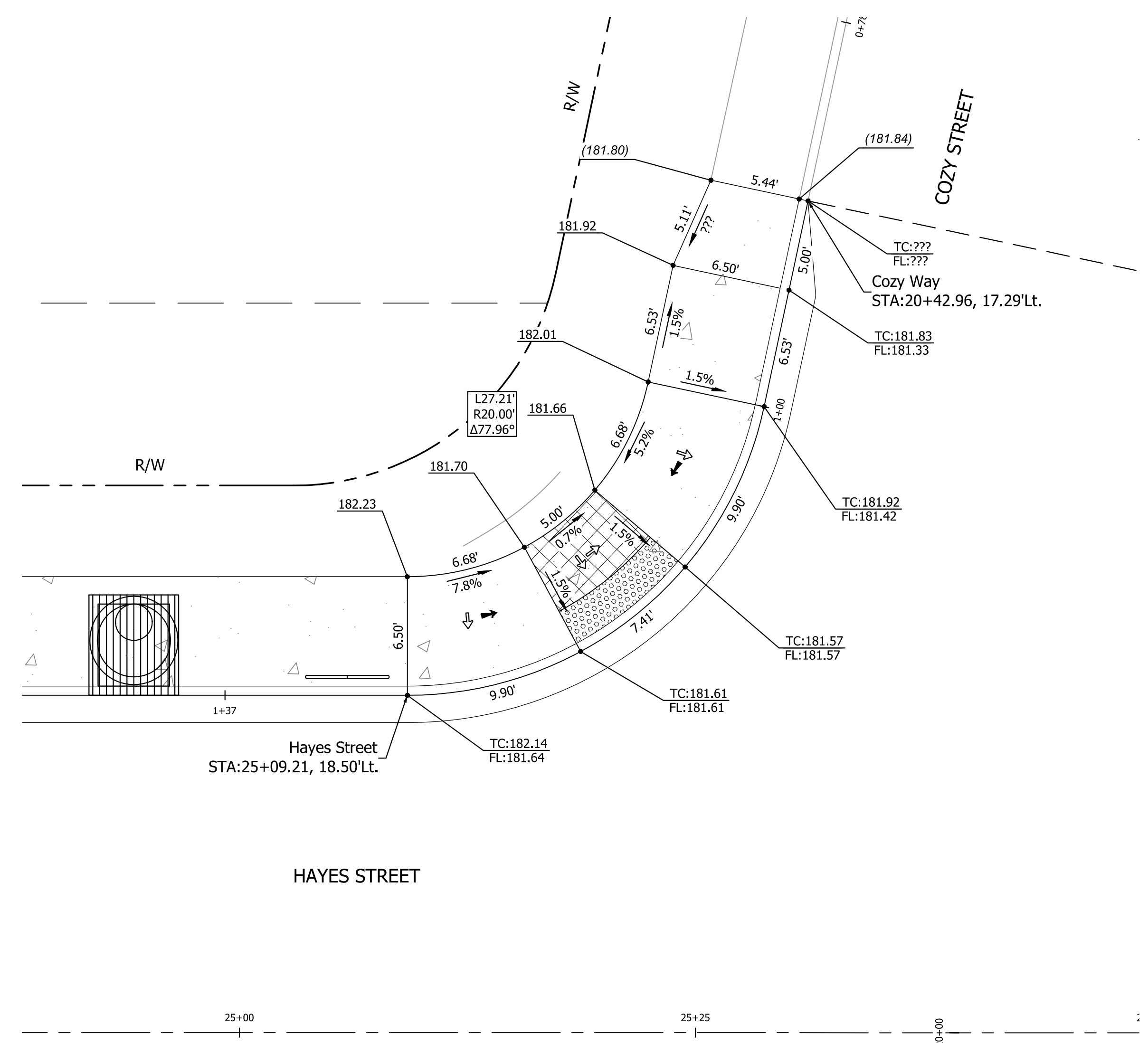

NW Curb Return

SIDEWALK RAMP GENERAL NOTES

- Contractor shall be responsible for meeting all Americans with Disabilities (ADA) requirements as defined by the public rights-of-way accessibility guidelines (PROWAG). Details and dimensions shown are approximate only and intended as a guide for initial layout purposes only and are not complete. Contractor shall take all necessary field measurements and otherwise verify all dimensions to meet ADA requirements. Should any error or inconsistency exist the contractor shall not proceed with the work affected until reported to the engineer for clarification or correction.
- Protect freshly poured concrete from vandalism or other damage for a minimum of twenty-four (24) hours or until cured enough to support typical use, whichever is longer. Any concrete damaged by vandalism or other causes shall be replaced at no cost to the city.
- See Standard ODOT Details RD902, RD904, RD906, and RD920 for Curb Ramp Construction on Sheet 2B-6

LEGEND

- Detectable Warning Surface
- Turning Space
- Slope 1.5%. (Max. 2.0% Finished Surface Slope) (normal Sidewalk Cross Slope)
- Slope 7.5%. (max. 8.3% Finished Surface Slope)

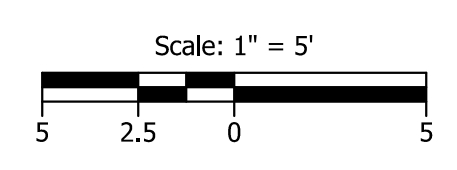
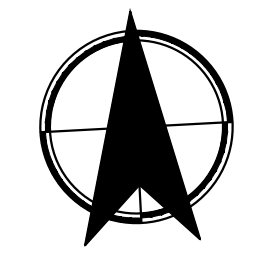

ABBREVIATION

- TC = Top of Curb Elevation
- BC = Bottom of Curb Elevation
- FL = Flow Line
- () = Match Extg. Grade

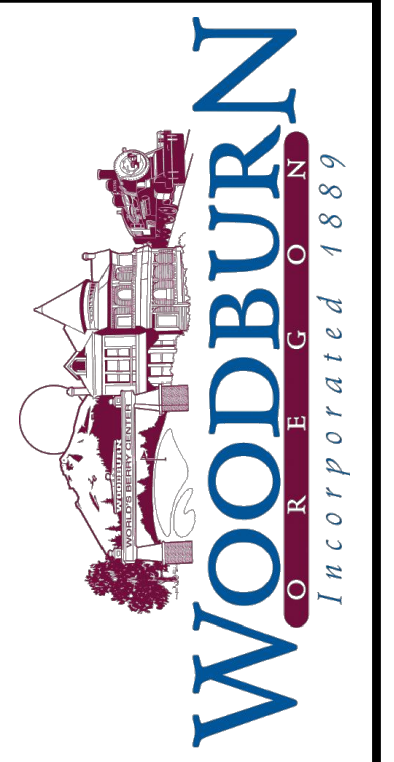

KITTELSON & ASSOCIATES
 851 SW 6TH AVENUE, SUITE 600
 PORTLAND, OR 97204
 P 503.228.5230 F 503.273.8169

#	DATE	REVISION	APP'D
0	05/25/22	ISSUE FOR CONSTRUCTION	FSW

Submission Date:
03/07/2022

Drawn: JCB/RMM
 Designed: NRS/JBK
 Checked: FSW

PROJECT NO.
2015-001-20

W. Hayes Street Improvements
 Cascade Avenue to Settlemier Avenue
 DETAILED GRADING PLAN
 COZY WAY CURB RAMPS

SHEET NO.
2E-3A

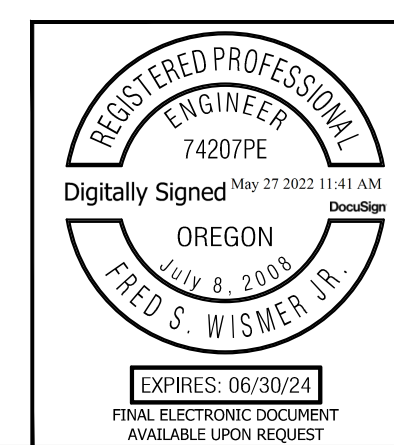

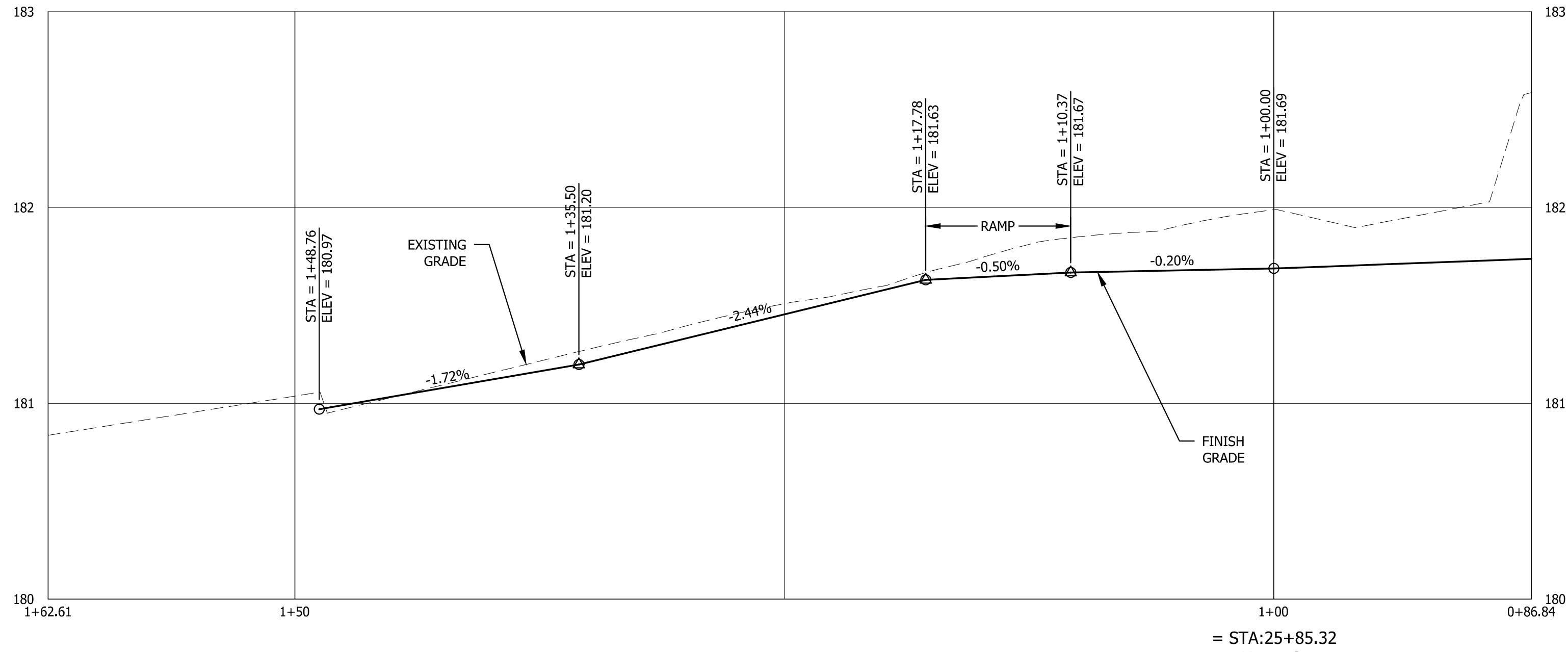

NE Curb Return

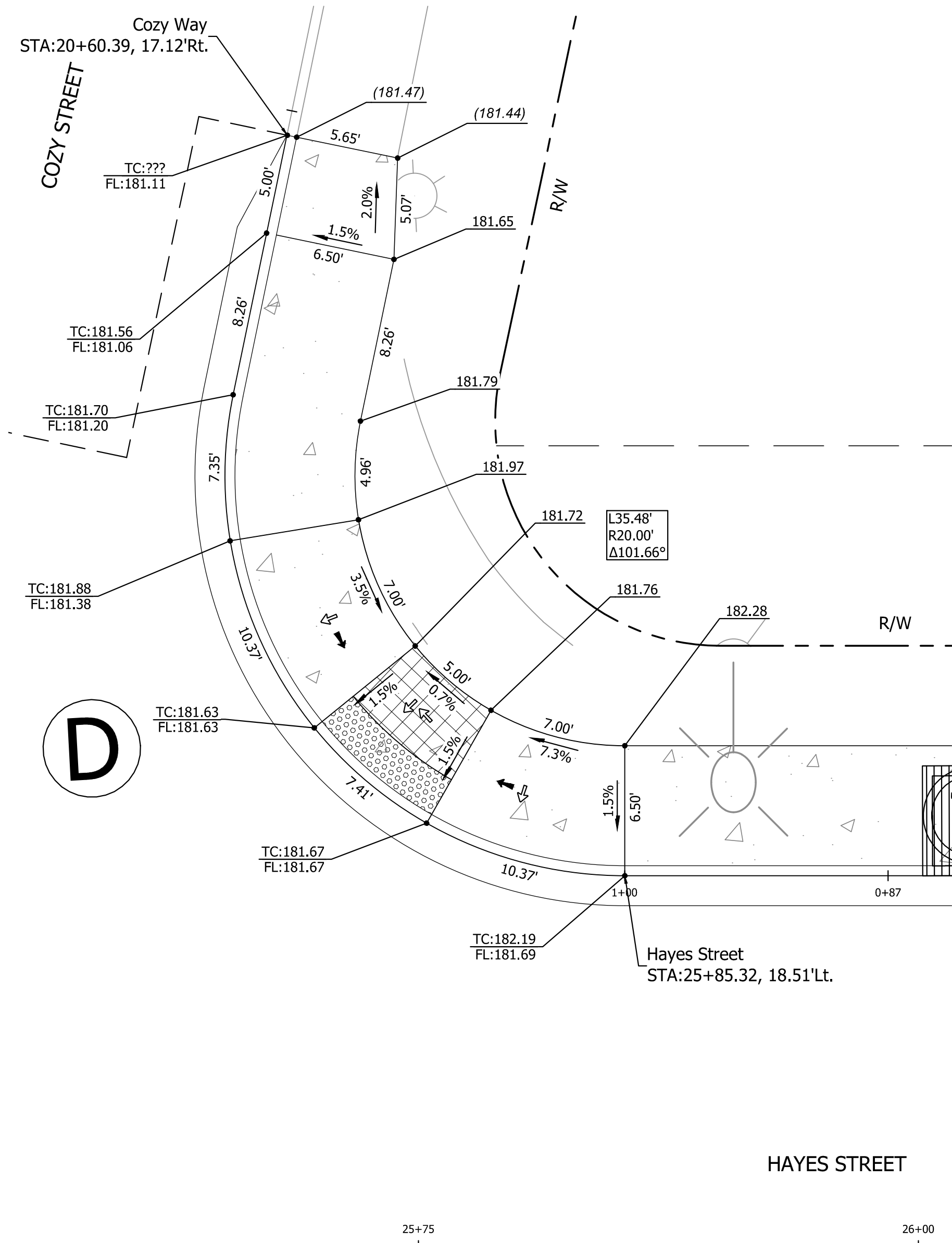

SIDEWALK RAMP GENERAL NOTES

- Contractor shall be responsible for meeting all Americans with Disabilities (ADA) requirements as defined by the public rights-of-way accessibility guidelines (PROWAG). Details and dimensions shown are approximate only and intended as a guide for initial layout purposes only and are not complete. Contractor shall take all necessary field measurements and otherwise verify all dimensions to meet ada requirements. Should any error or inconsistency exist the contractor shall not proceed with the work affected until reported to the engineer for clarification or correction.
- Protect freshly poured concrete from vandalism or other damage for a minimum of twenty-four (24) hours or until cured enough to support typical use, whichever is longer. Any concrete damaged by vandalism or other causes shall be replaced at no cost to the city.
- See Standard ODOT Details RD902, RD904, RD906, and RD920 for Curb Ramp Construction on Sheet 2B-6

LEGEND

- Detectable Warning Surface
- Turning Space
- Slope 1.5% (max. 2.0% Finished Surface Slope) (normal Sidewalk Cross Slope)
- Slope 7.5% (max. 8.3% Finished Surface Slope)

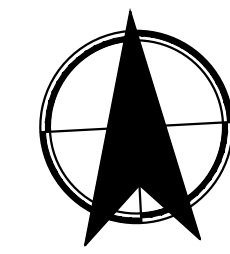

ABBREVIATION

- TC = Top of Curb Elevation
- BC = Bottom of Curb Elevation
- FL = Flow Line
- () = Match Extg. Grade

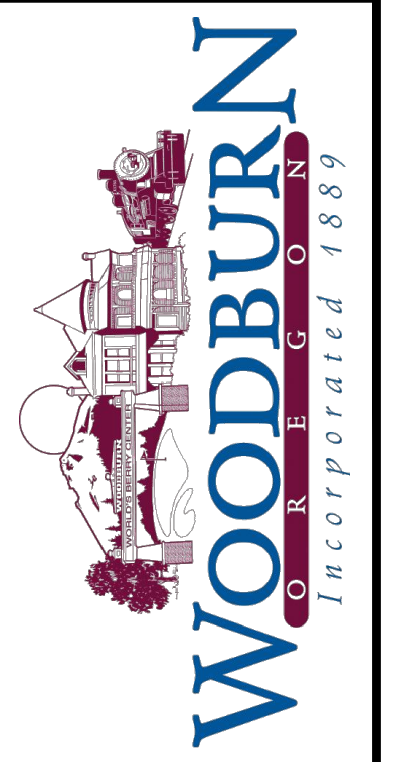
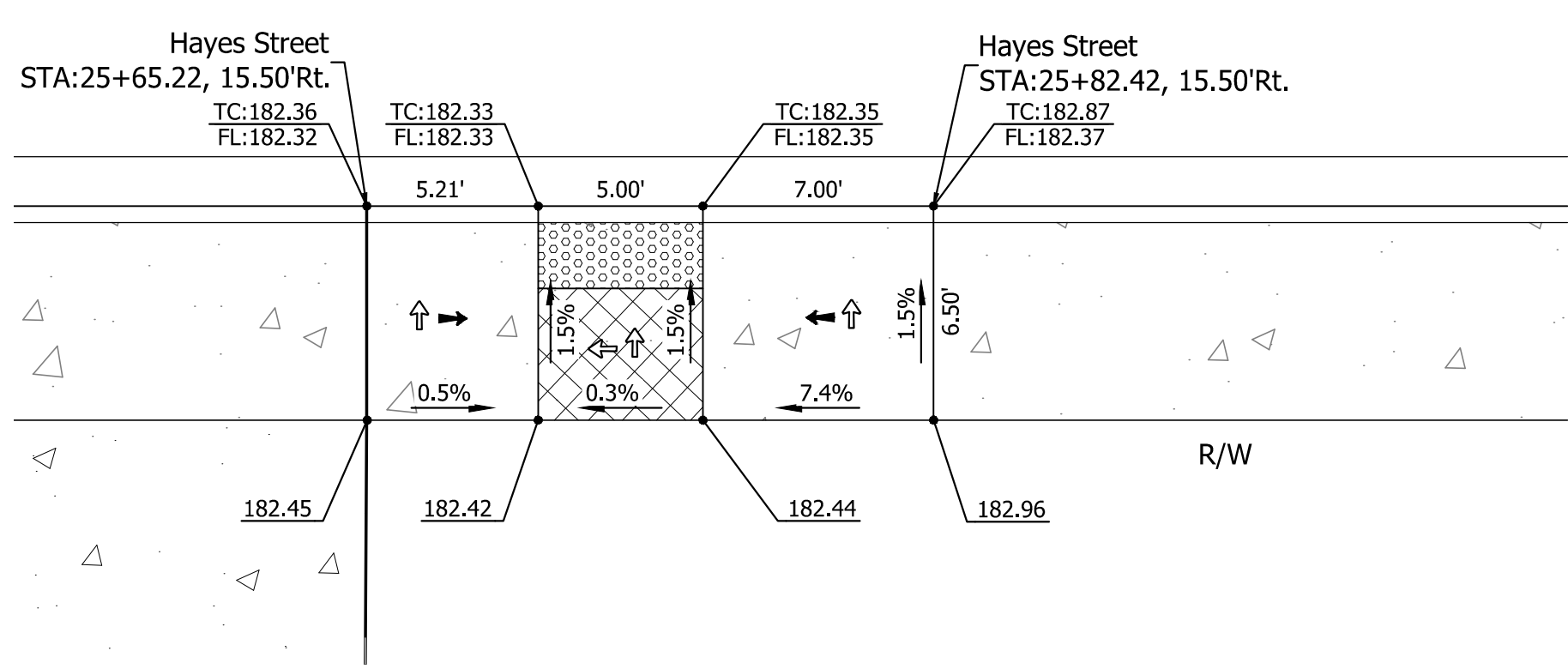

KITTELSON & ASSOCIATES
 851 SW 6TH AVENUE, SUITE 600
 PORTLAND, OR 97204
 P 503.228.5230 F 503.273.8169

NO.	DATE	REVISION	APP'D
0	05/25/22	ISSUE FOR CONSTRUCTION	FSW

Submission Date: 03/07/2022

Drawn: JCB/RMM Designed: NRS/JBK Checked: FSW

PROJECT NO. 2015-001-20

W. Hayes Street Improvements
 Cascade Avenue to Settlemier Avenue
 DETAILED GRADING PLAN
 COZY WAY CURB RAMPS

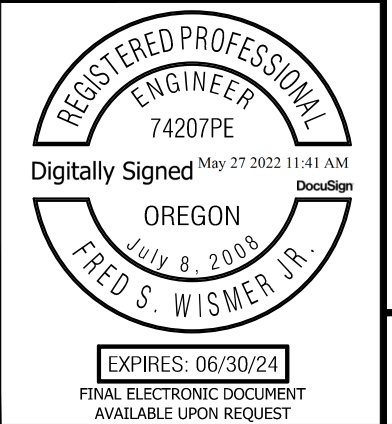

SHEET NO. 2E-3B

Plot Stamp: 5/27/2022 11:17:14 AM - Fred Wismer
 File: H:\24\24512 - W. Hayes Street\design\CD\CD-Intersection-Grading-Plans-24512.dwg

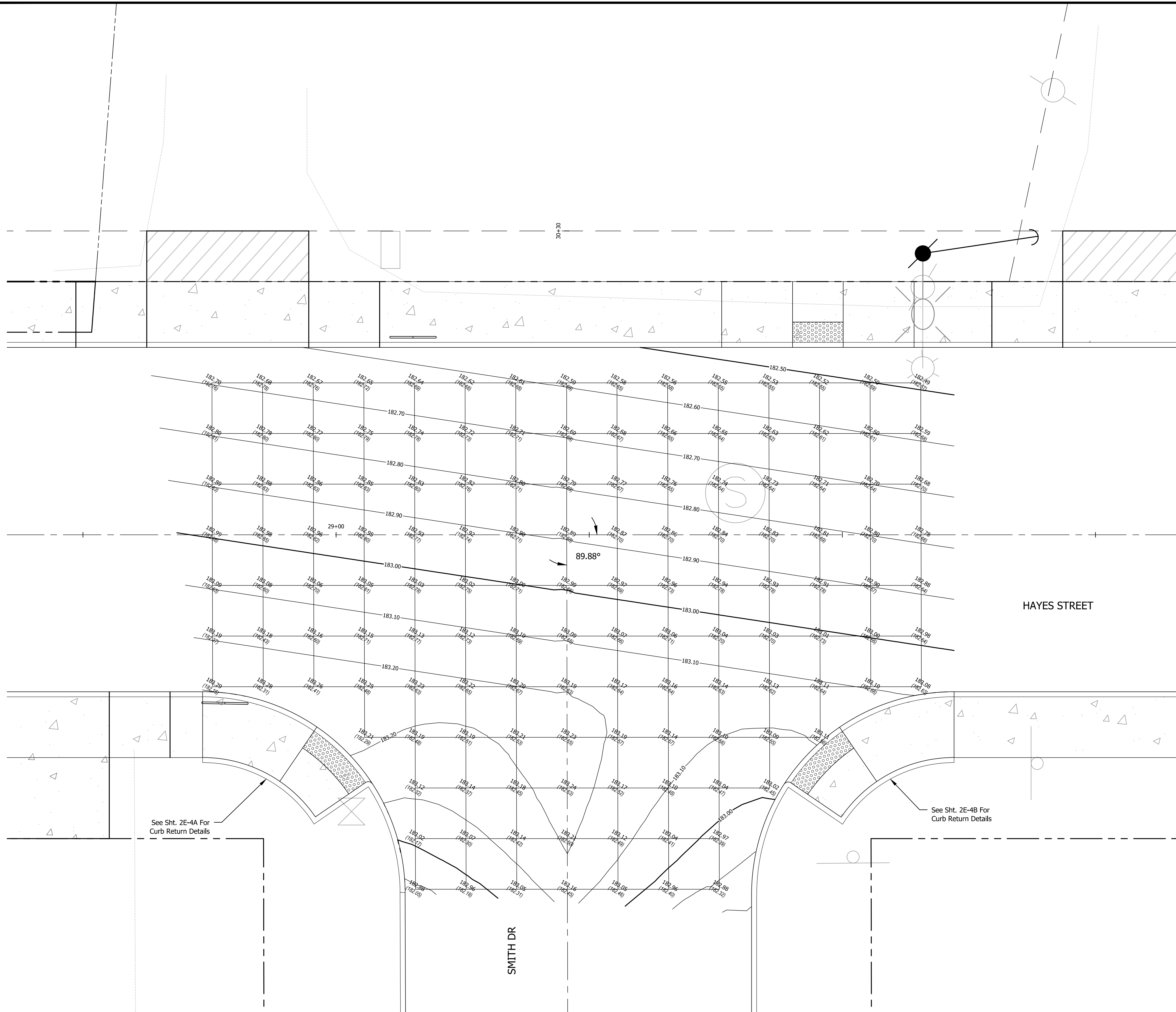

- GENERAL NOTES**
- Elevations Are Top Of Pavement Finished Grade Unless Otherwise Noted
 - Contours Are Top Of Pavement Finished Grade
 - Grids Are 5' Spacing
 - Extg. Grade Elevations = (XXX.XX)
Prop. Grade Elevations = XXX.XX

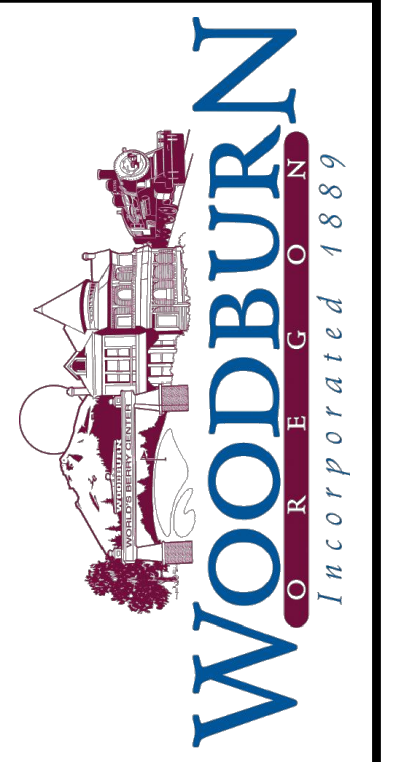
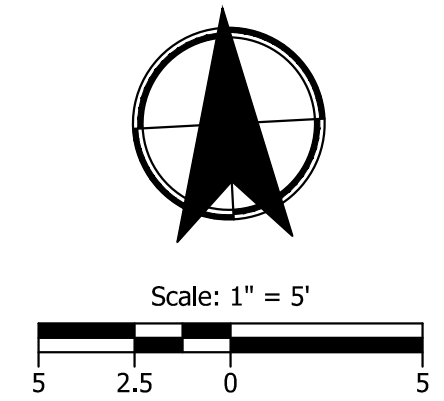

KITTELSON & ASSOCIATES
 851 SW 6TH AVENUE, SUITE 600
 PORTLAND, OR 97204
 P 503.228.5230 F 503.273.8169

NO.	DATE	REVISION	APP'D
01	05/25/22	ISSUE FOR CONSTRUCTION	FSW

Submission Date: 03/07/2022
 Drawn: JCB/RMM Designed: NRS/JBK Checked: FSW

PROJECT NO. 2015-001-20
W. Hayes Street Improvements
 Cascade Avenue to Settlemier Avenue
 INTERSECTION GRADING PLAN
 SMITH DRIVE

SHEET NO. 2E-4

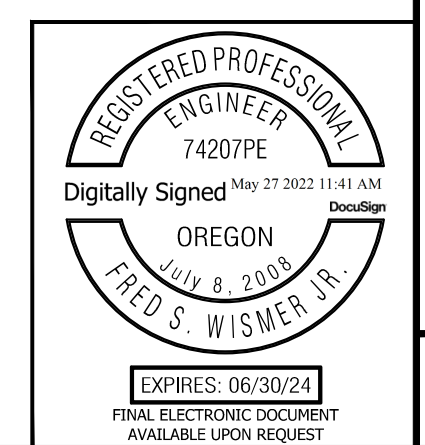

NO.	DATE	REVISION	APP'D
0	05/25/22	ISSUE FOR CONSTRUCTION	FSW

Submission Date:
03/07/2022

Drawn: JCB/RMM Designed: NRS/JBK Checked: FSW

PROJECT NO.
2015-001-20

W. Hayes Street Improvements
Cascade Avenue to Settlemier Avenue





DETAILED GRADING PLAN
SMITH DRIVE CURB RAMPS

SHEET NO.
2E-4A

SIDEWALK RAMP GENERAL NOTES

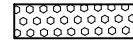
- Contractor shall be responsible for meeting all Americans with disabilities (ADA) requirements as defined by the public rights-of-way accessibility guidelines (PROWAG). Details and dimensions shown are approximate only and intended as a guide for initial layout purposes only and are not complete. Contractor shall take all necessary field measurements and otherwise verify all dimensions to meet ada requirements. Should any error or inconsistency exist the contractor shall not proceed with the work affected until reported to the engineer for clarification or correction.
- Protect freshly poured concrete from vandalism or other damage for a minimum of twenty-four (24) hours or until cured enough to support typical use, whichever is longer. Any concrete damaged by vandalism or other causes shall be replaced at no cost to the city.
- See Standard ODOT Details RD902, RD904, RD906, and RD920 for Curb Ramp Construction on Sheet 2B-6

LEGEND

-  Detectable Warning Surface
-  Turning Space
-  Slope 1.5%, (max. 2.0% Finished Surface Slope) (normal Sidewalk Cross Slope)
-  Slope 7.5%, (max. 8.3% Finished Surface Slope)

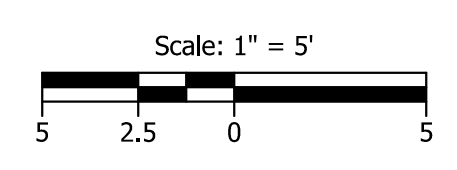
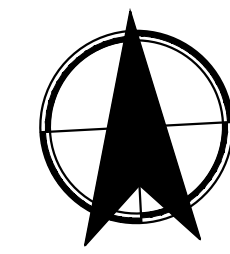

ABBREVIATION

- TC = Top of Curb Elevation
- BC = Bottom of Curb Elevation
- FL = Flow Line
- () = Match Extg. Grade

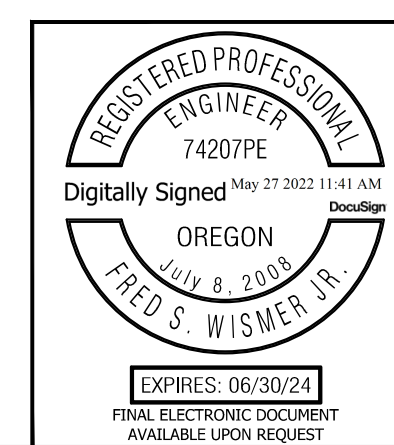
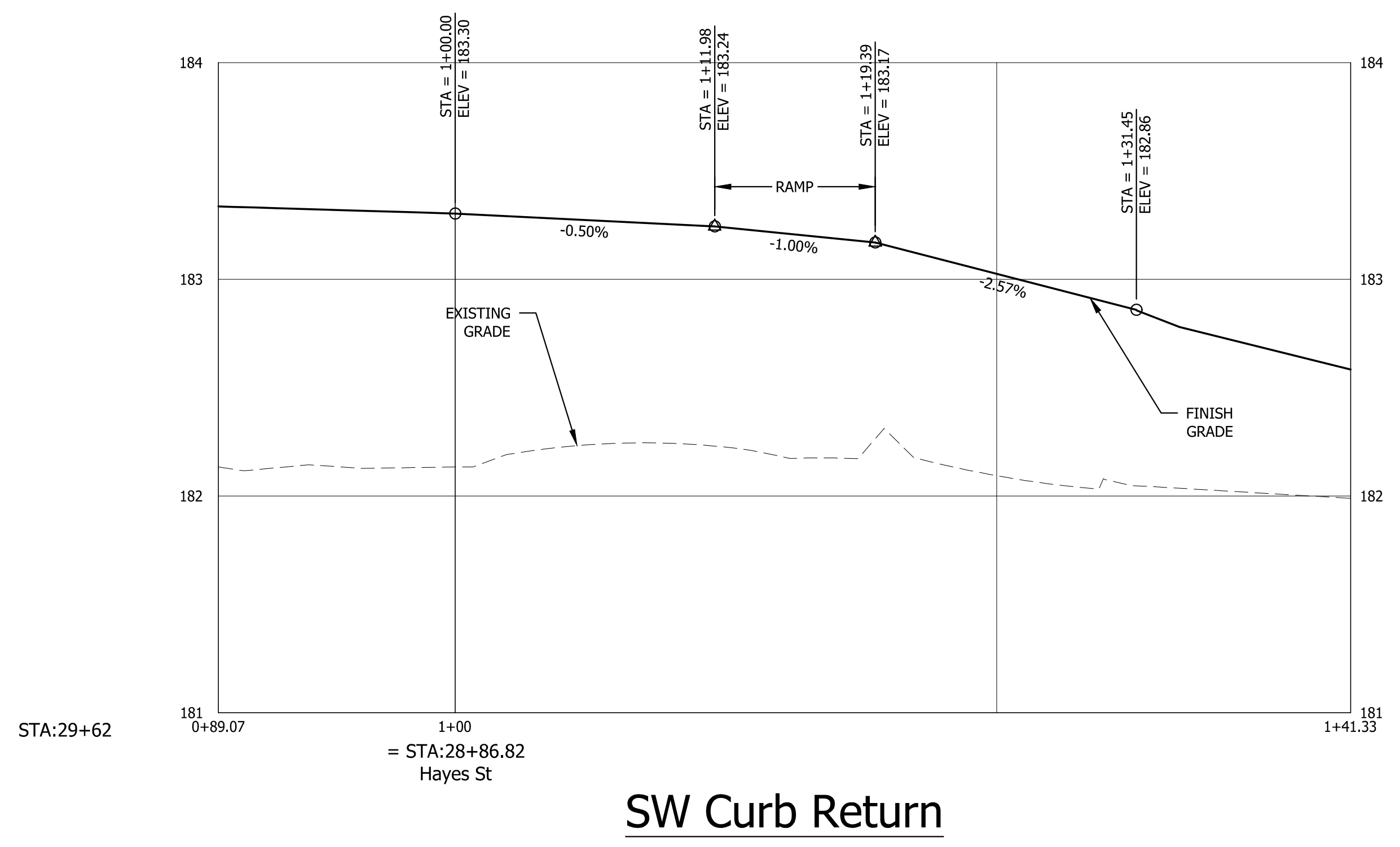
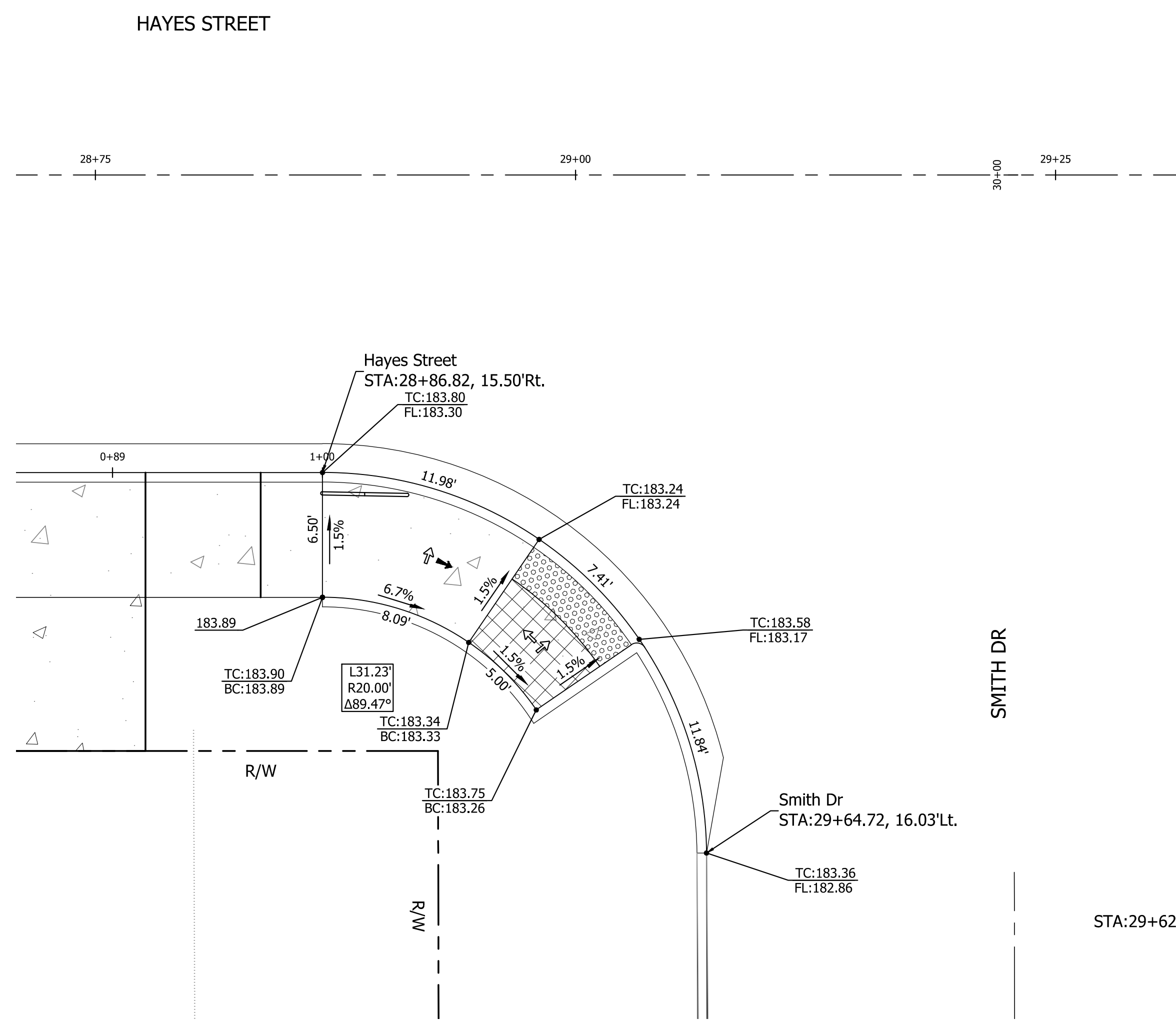

Plot Stamp: 5/27/2022 11:17:44 AM - Fred Wismer
 File: H:\24\24512 - W. Hayes Street\design\CD\CD-Detailed-Grading-Plans-24512.dwg

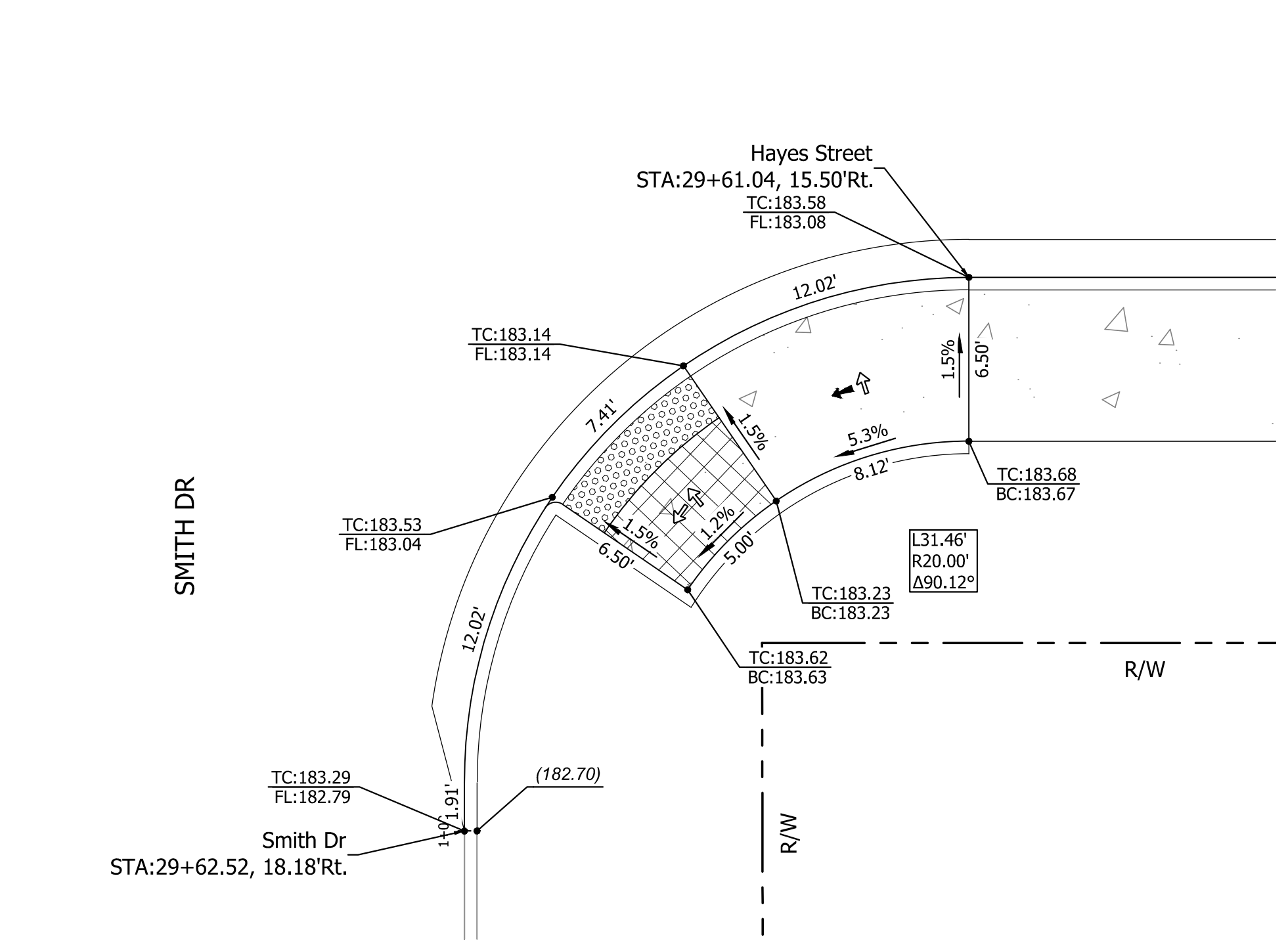
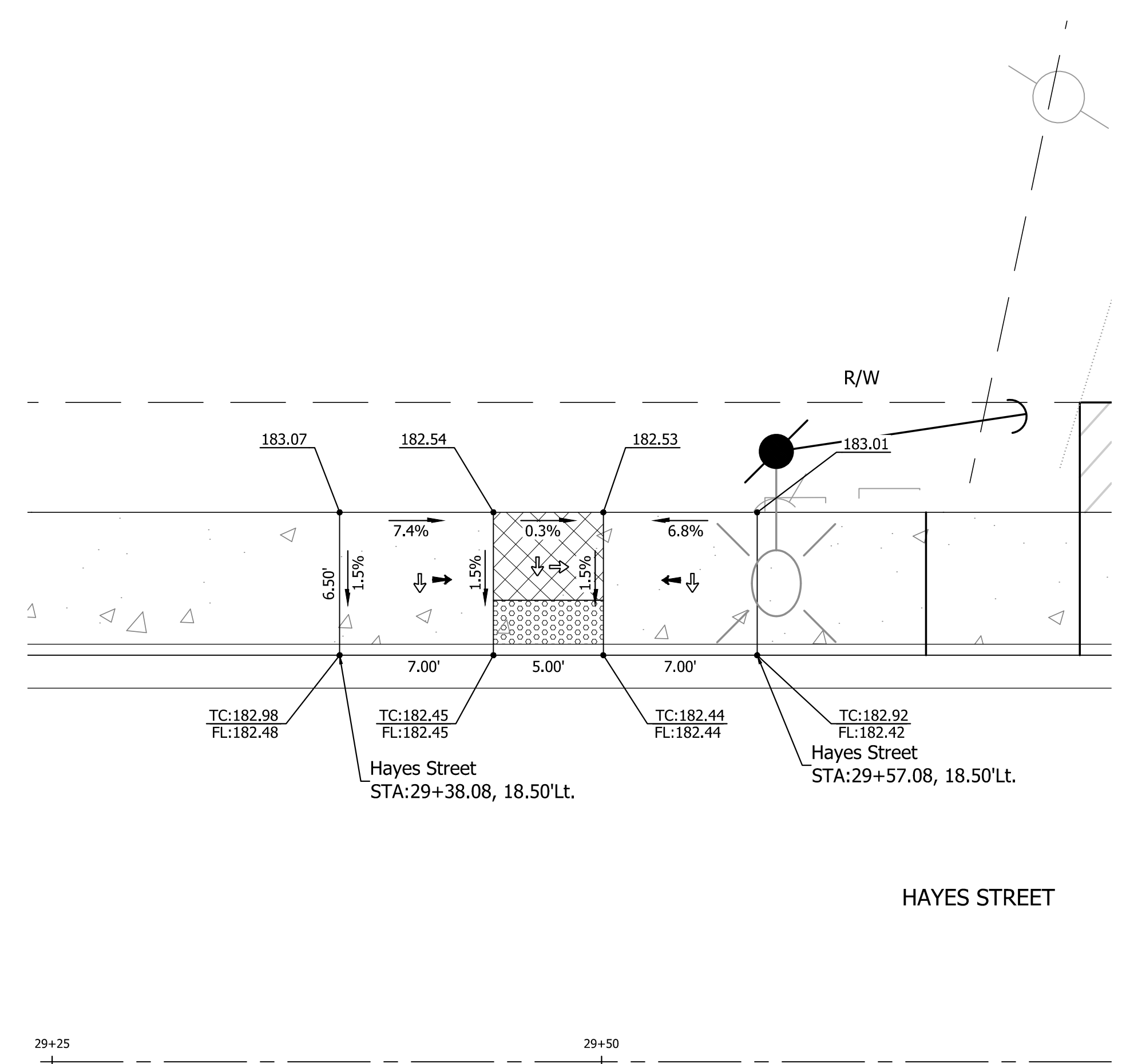
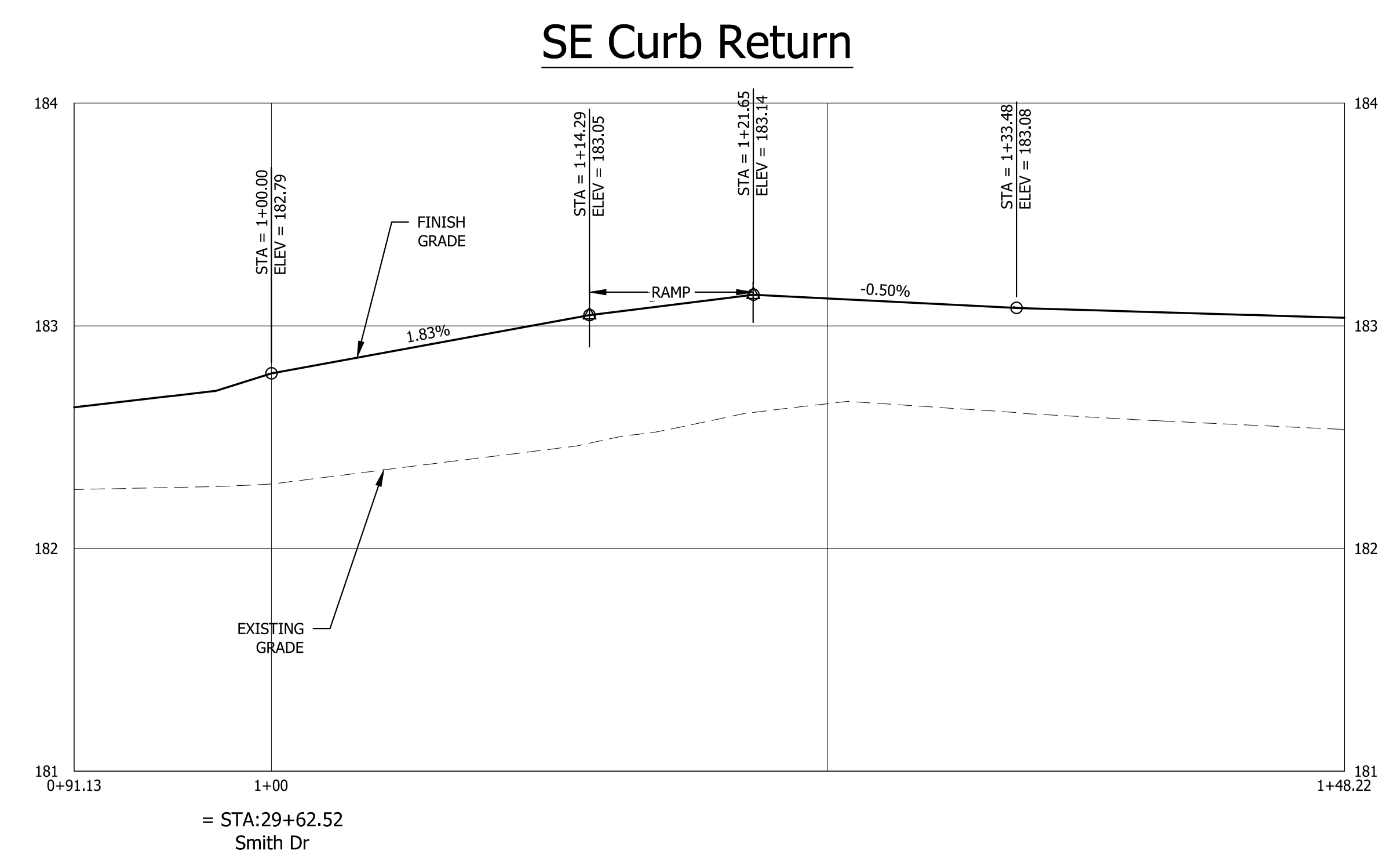

SIDEWALK RAMP GENERAL NOTES

- Contractor shall be responsible for meeting all Americans with Disabilities (ADA) requirements as defined by the public rights-of-way accessibility guidelines (PROWAG). Details and dimensions shown are approximate only and intended as a guide for initial layout purposes only and are not complete. Contractor shall take all necessary field measurements and otherwise verify all dimensions to meet ADA requirements. Should any error or inconsistency exist the contractor shall not proceed with the work affected until reported to the engineer for clarification or correction.
- Protect freshly poured concrete from vandalism or other damage for a minimum of twenty-four (24) hours or until cured enough to support typical use, whichever is longer. Any concrete damaged by vandalism or other causes shall be replaced at no cost to the city.
- See Standard ODOT Details RD902, RD904, RD906, and RD920 for Curb Ramp Construction on Sheet 2B-6

LEGEND

- Detectable Warning Surface
- Turning Space
- Slope 1.5%. (max. 2.0% Finished Surface Slope) (normal Sidewalk Cross Slope)
- Slope 7.5%. (max. 8.3% Finished Surface Slope)

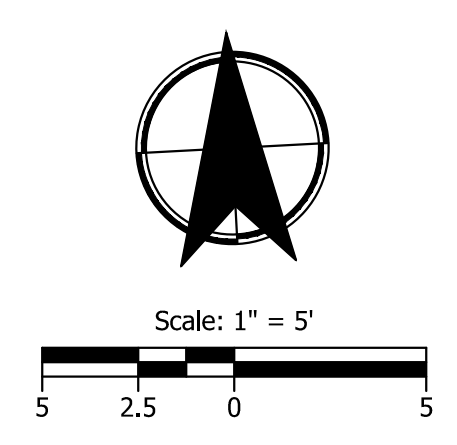

ABBREVIATION

- TC = Top of Curb Elevation
- BC = Bottom of Curb Elevation
- FL = Flow Line
- () = Match Extg. Grade

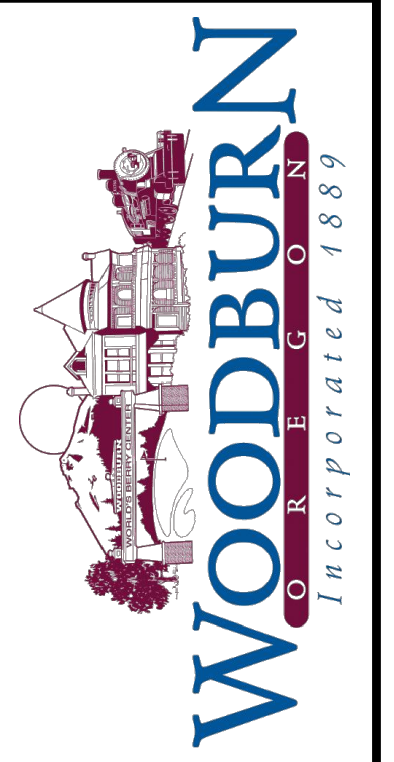

KITTELSON & ASSOCIATES
 851 SW 6TH AVENUE, SUITE 600
 PORTLAND, OR 97204
 P 503.228.5230 F 503.273.8169

NO.	DATE	REVISION	APP'D
0	05/25/22	ISSUE FOR CONSTRUCTION	FSW

Submission Date: 03/07/2022
 Drawn: JCB/RMM
 Designed: NRS/JBK
 Checked: FSW

PROJECT NO. 2015-001-20

W. Hayes Street Improvements
 Cascade Avenue to Settlemier Avenue

DETAILED GRADING PLAN
 SMITH DRIVE CURB RAMPS



SHEET NO. 2E-4B

NO.	DATE	REVISION	APP'D
01	05/25/22	ISSUE FOR CONSTRUCTION	FSW

Submission Date: 03/07/2022

Drawn: JCB/RMM Designed: NRS/JBK Checked: FSW

PROJECT NO. 2015-001-20

W. Hayes Street Improvements
 Cascade Avenue to Settlemier Avenue
 INTERSECTION GRADING PLAN
 LEASURE STREET

SHEET NO. 2E-5

GENERAL NOTES

- Elevations Are Top Of Pavement Finished Grade Unless Otherwise Noted
- Contours Are Top Of Pavement Finished Grade
- Grids Are 5' Spacing
- Extg. Grade Elevations = (XXX.XX)
 Prop. Grade Elevations = XXX.XX

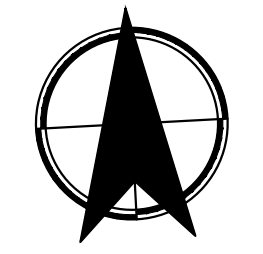

Scale: 1" = 5'
 5 2.5 0 5

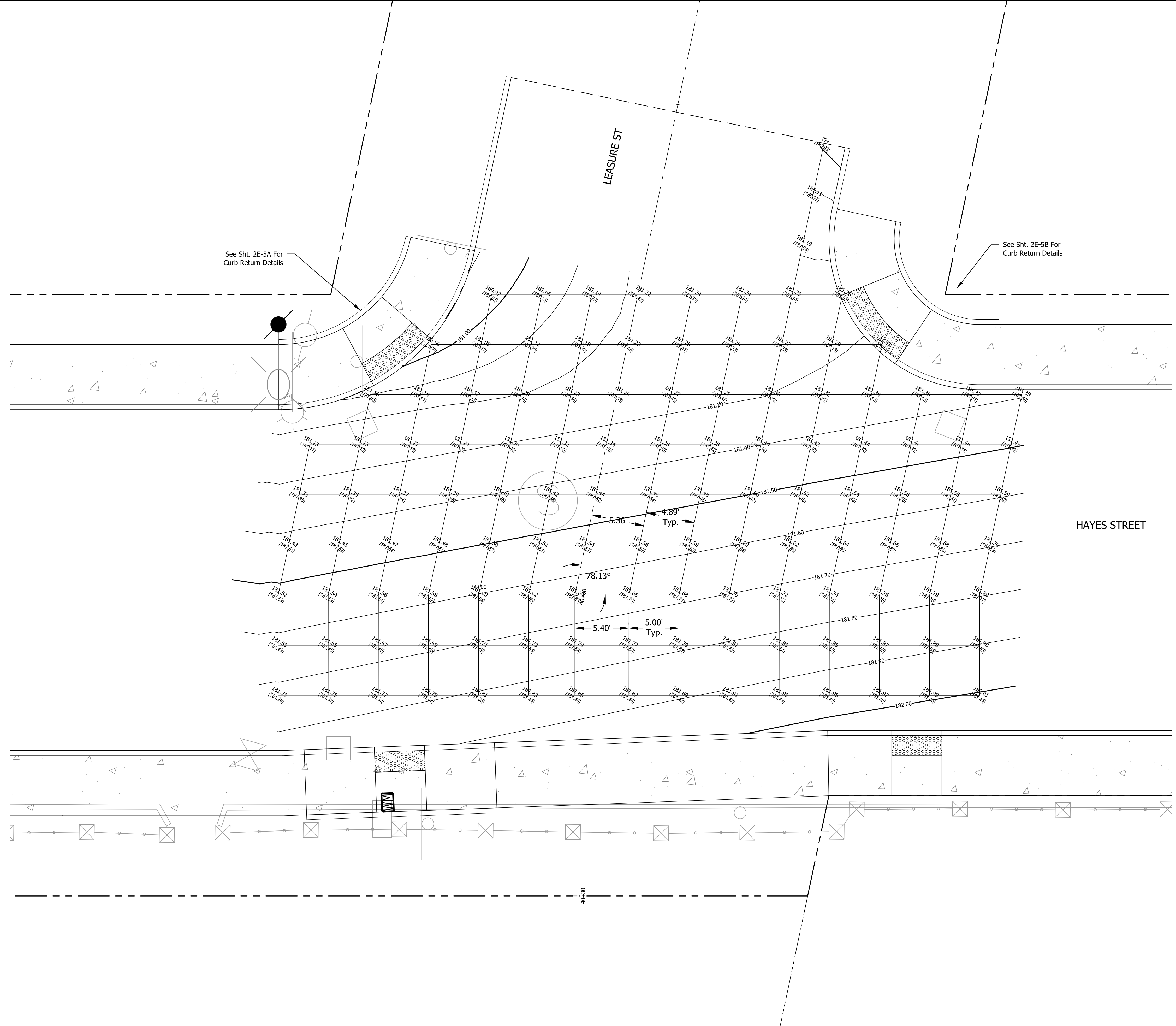

Plot Stamp: 5/27/2022 11:18:06 AM - Fred Wismer
 File: H:\24\24512 - W. Hayes Street\design\CD\CD-Detailed-Grading-Plans-24512.dwg

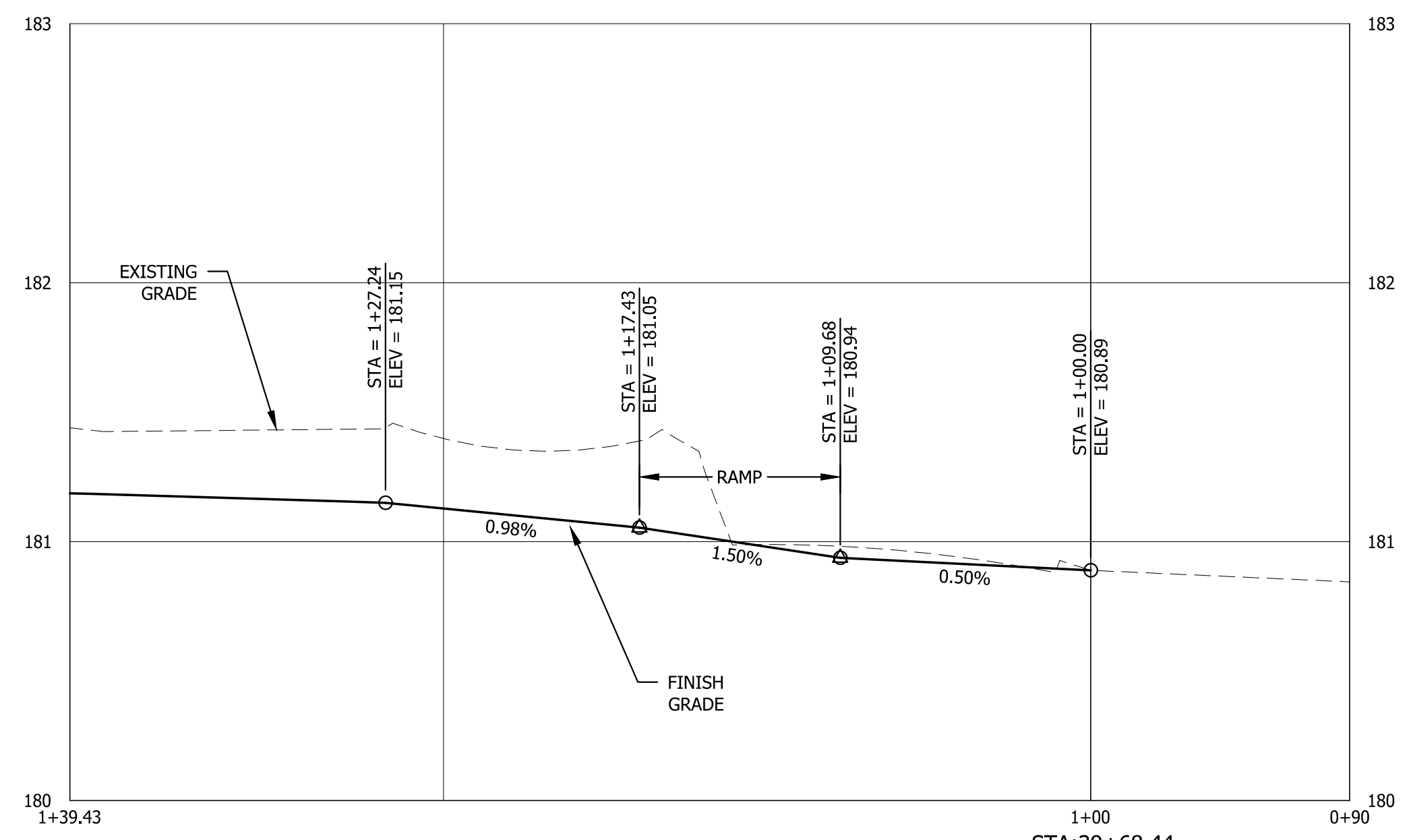
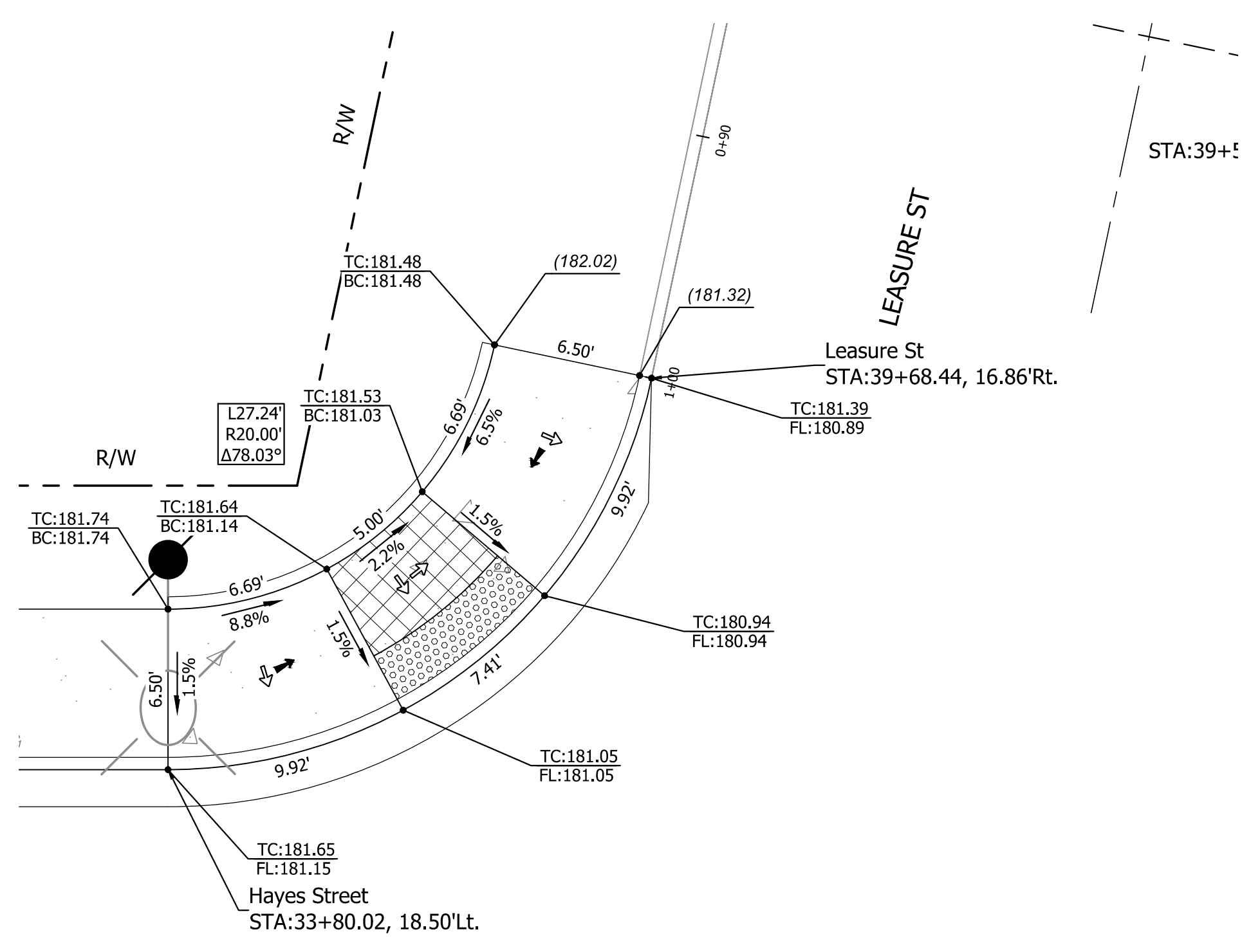

NW Curb Return

SIDEWALK RAMP GENERAL NOTES

- Contractor shall be responsible for meeting all Americans with Disabilities (ADA) requirements as defined by the public rights-of-way accessibility guidelines (PROWAG). Details and dimensions shown are approximate only and intended as a guide for initial layout purposes only and are not complete. Contractor shall take all necessary field measurements and otherwise verify all dimensions to meet ADA requirements. Should any error or inconsistency exist the contractor shall not proceed with the work affected until reported to the engineer for clarification or correction.
- Protect freshly poured concrete from vandalism or other damage for a minimum of twenty-four (24) hours or until cured enough to support typical use, whichever is longer. Any concrete damaged by vandalism or other causes shall be replaced at no cost to the city.
- See Standard ODOT Details RD902, RD904, RD906, and RD920 for Curb Ramp Construction on Sheet 2B-6

LEGEND

- Detectable Warning Surface
- Turning Space
- Slope 1.5%. (max. 2.0% Finished Surface Slope) (normal Sidewalk Cross Slope)
- Slope 7.5%. (max. 8.3% Finished Surface Slope)

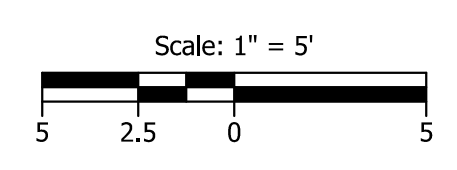
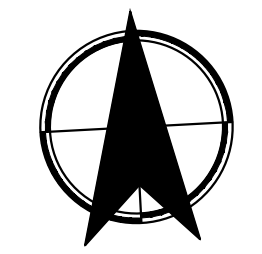

ABBREVIATION

- TC = Top of Curb Elevation
- BC = Bottom of Curb Elevation
- FL = Flow Line
- () = Match Extg. Grade

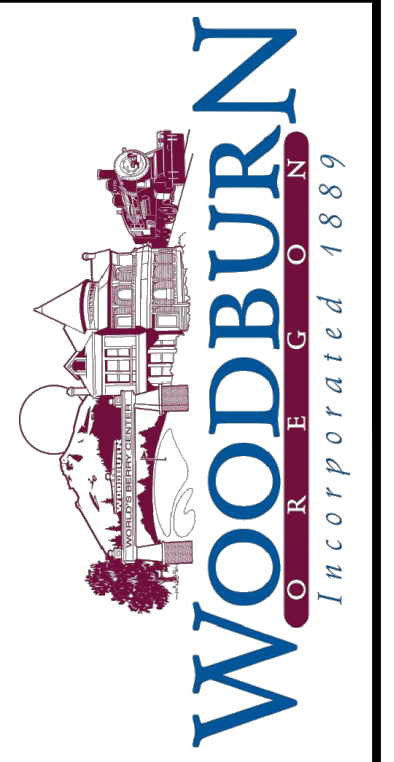
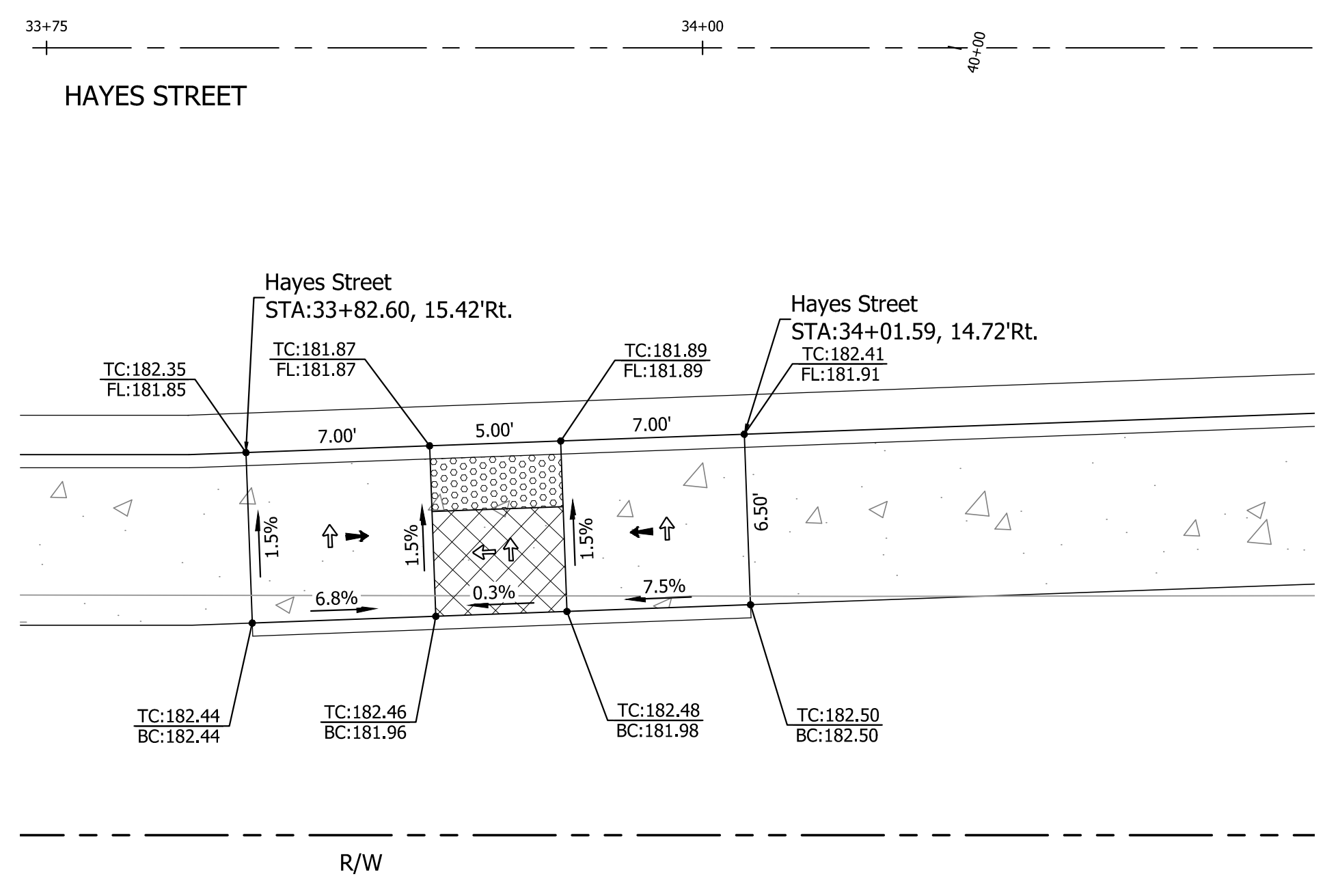

KITTELSON & ASSOCIATES
 851 SW 6TH AVENUE, SUITE 600
 PORTLAND, OR 97204
 P 503.228.5230 F 503.273.8169

NO.	DATE	REVISION	APP'D
0	05/25/22	ISSUE FOR CONSTRUCTION	FSW

Submission Date: 03/07/2022
 Drawn: JCB/RMM
 Designed: NRS/JBK
 Checked: FSW

PROJECT NO. 2015-001-20

W. Hayes Street Improvements
 Cascade Avenue to Settlemier Avenue
 DETAILED GRADING PLAN
 LEASURE STREET CURB RAMPS

SHEET NO. 2E-5A

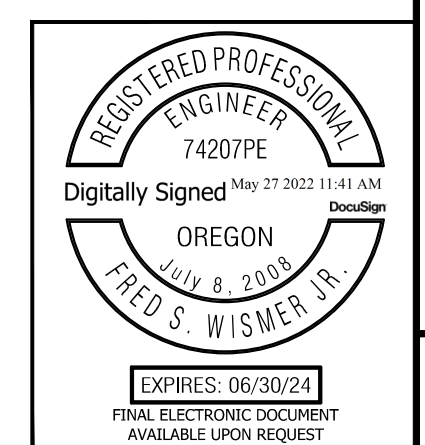

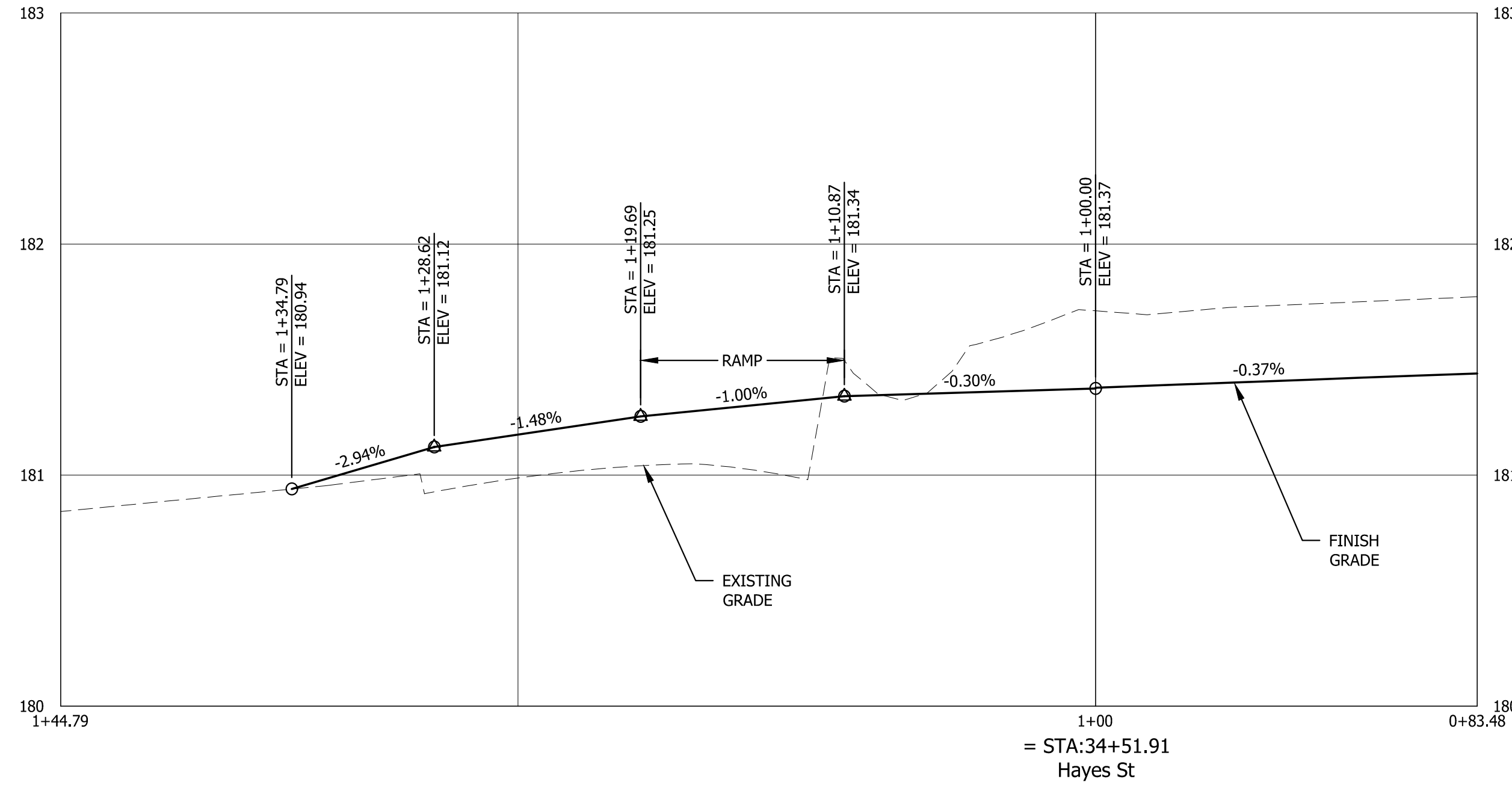

NE Curb Return

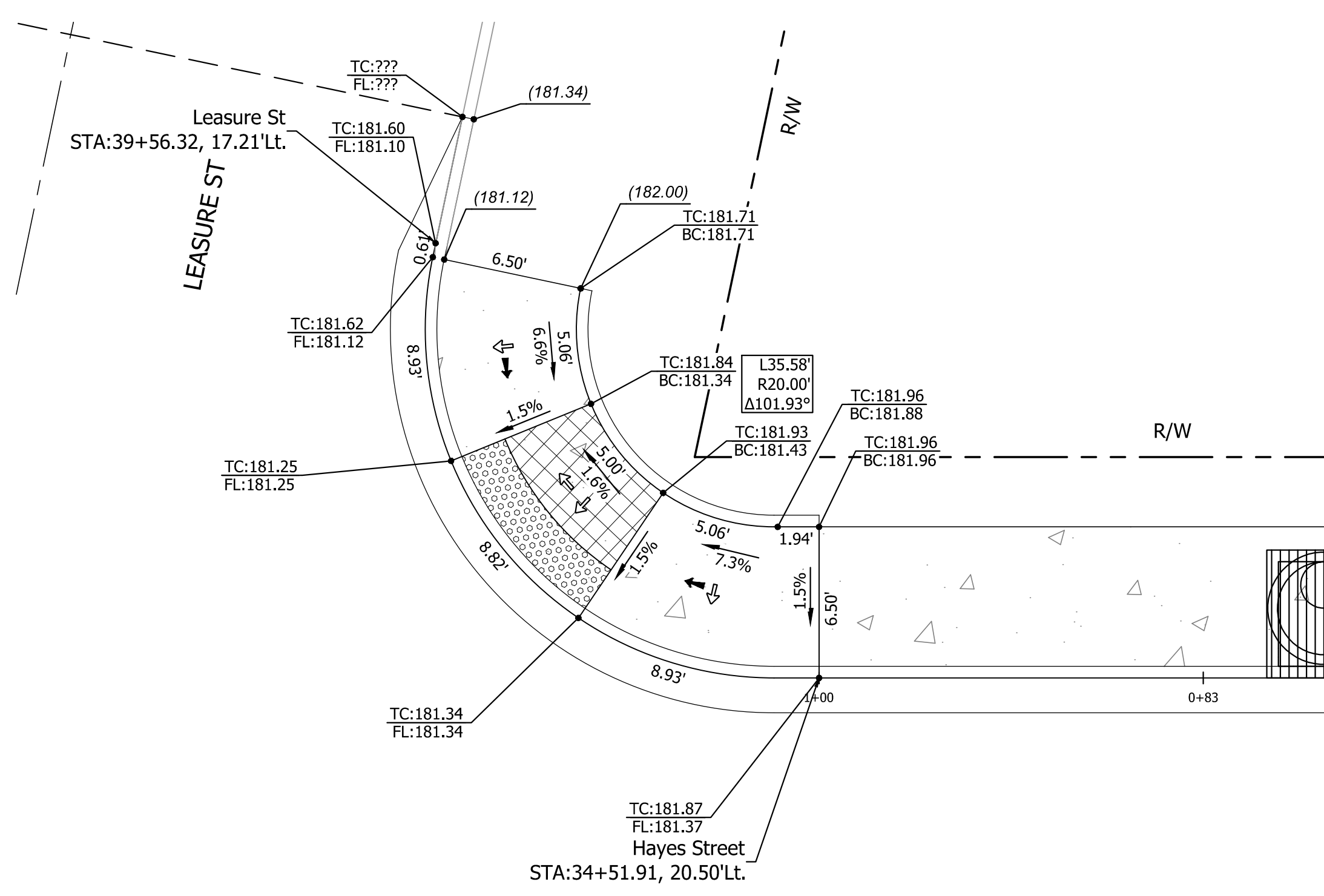

SIDEWALK RAMP GENERAL NOTES

- Contractor shall be responsible for meeting all Americans with disabilities (ADA) requirements as defined by the public rights-of-way accessibility guidelines (PROWAG). Details and dimensions shown are approximate only and intended as a guide for initial layout purposes only and are not complete. Contractor shall take all necessary field measurements and otherwise verify all dimensions to meet ada requirements. Should any error or inconsistency exist the contractor shall not proceed with the work affected until reported to the engineer for clarification or correction.
- Protect freshly poured concrete from vandalism or other damage for a minimum of twenty-four (24) hours or until cured enough to support typical use, whichever is longer. Any concrete damaged by vandalism or other causes shall be replaced at no cost to the city.
- See Standard ODOT Details RD902, RD904, RD906, and RD920 for Curb Ramp Construction on Sheet 2B-6

LEGEND

- Detectable Warning Surface
- Turning Space
- Slope 1.5% (max. 2.0% Finished Surface Slope) (normal Sidewalk Cross Slope)
- Slope 7.5% (max. 8.3% Finished Surface Slope)

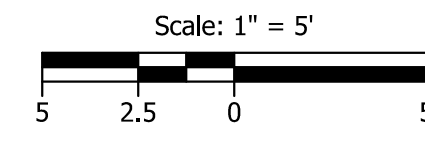
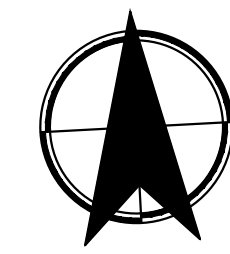

ABBREVIATION

- TC = Top of Curb Elevation
- BC = Bottom of Curb Elevation
- FL = Flow Line
- () = Match Extg. Grade

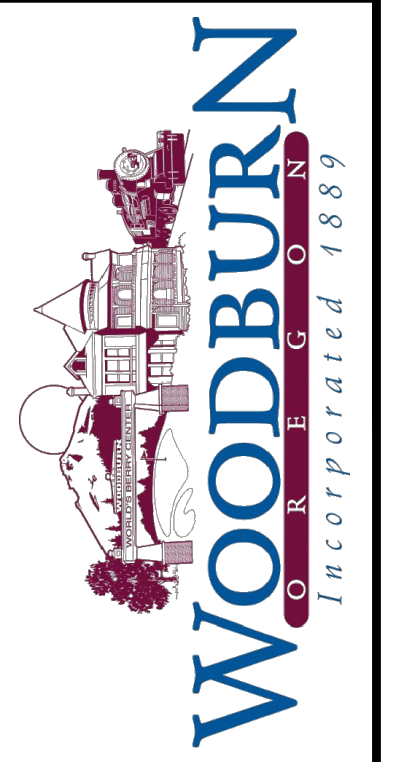
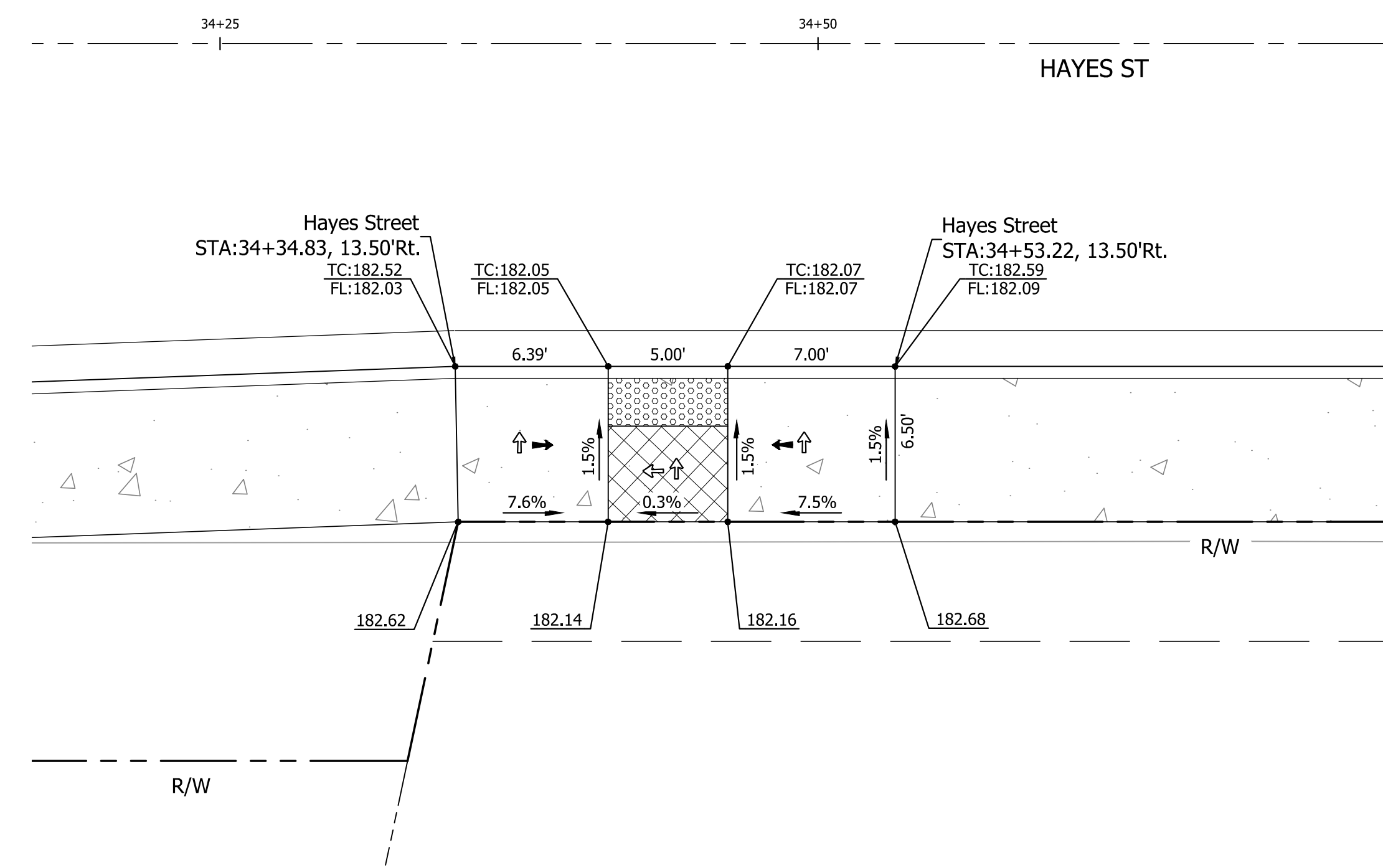

KITTELSON & ASSOCIATES
 851 SW 6TH AVENUE, SUITE 600
 PORTLAND, OR 97204
 P 503.228.5230 F 503.273.8169

NO.	DATE	REVISION	APP'D
01	05/25/22	ISSUE FOR CONSTRUCTION	FSW

Submission Date: 03/07/2022

Drawn: JCB/RMM, Designed: NRS/JBK, Checked: FSW

PROJECT NO. 2015-001-20

W. Hayes Street Improvements
 Cascade Avenue to Settlemier Avenue
 DETAILED GRADING PLAN
 LEASURE STREET CURB RAMPS

SHEET NO. 2E-5B

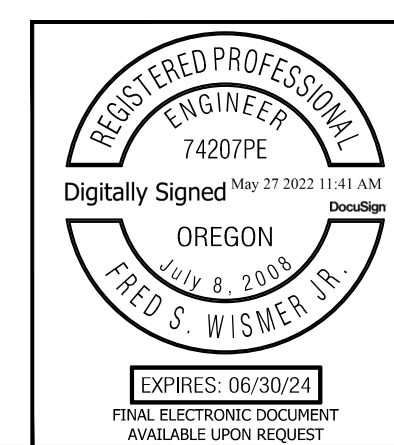

Plot Stamp: 5/27/2022 11:18:48 AM - Fred Wismer
 File: H:\24\24512 - W. Hayes Street\design\CD\CD-Detailed-Grading-Plans-24512.dwg

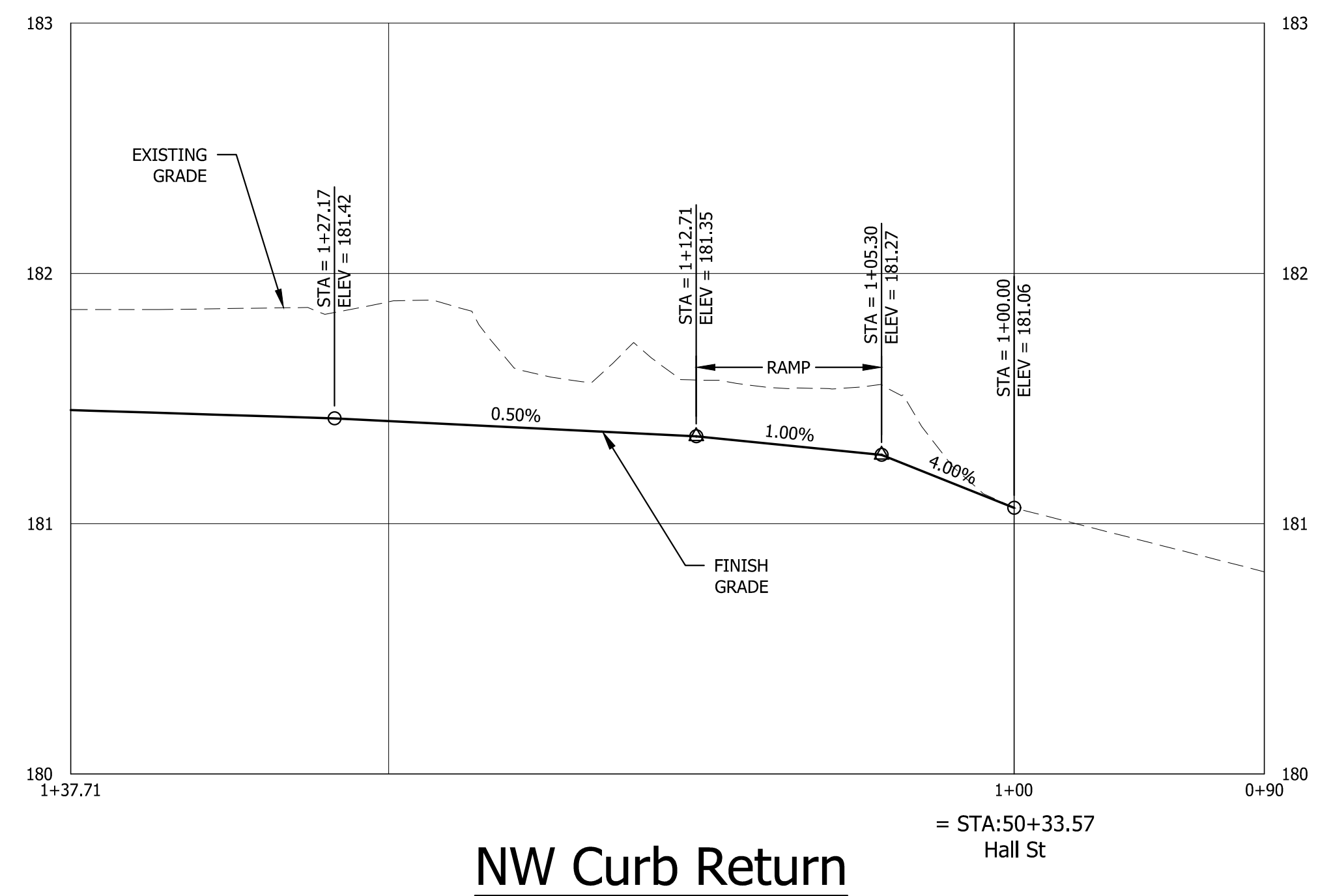
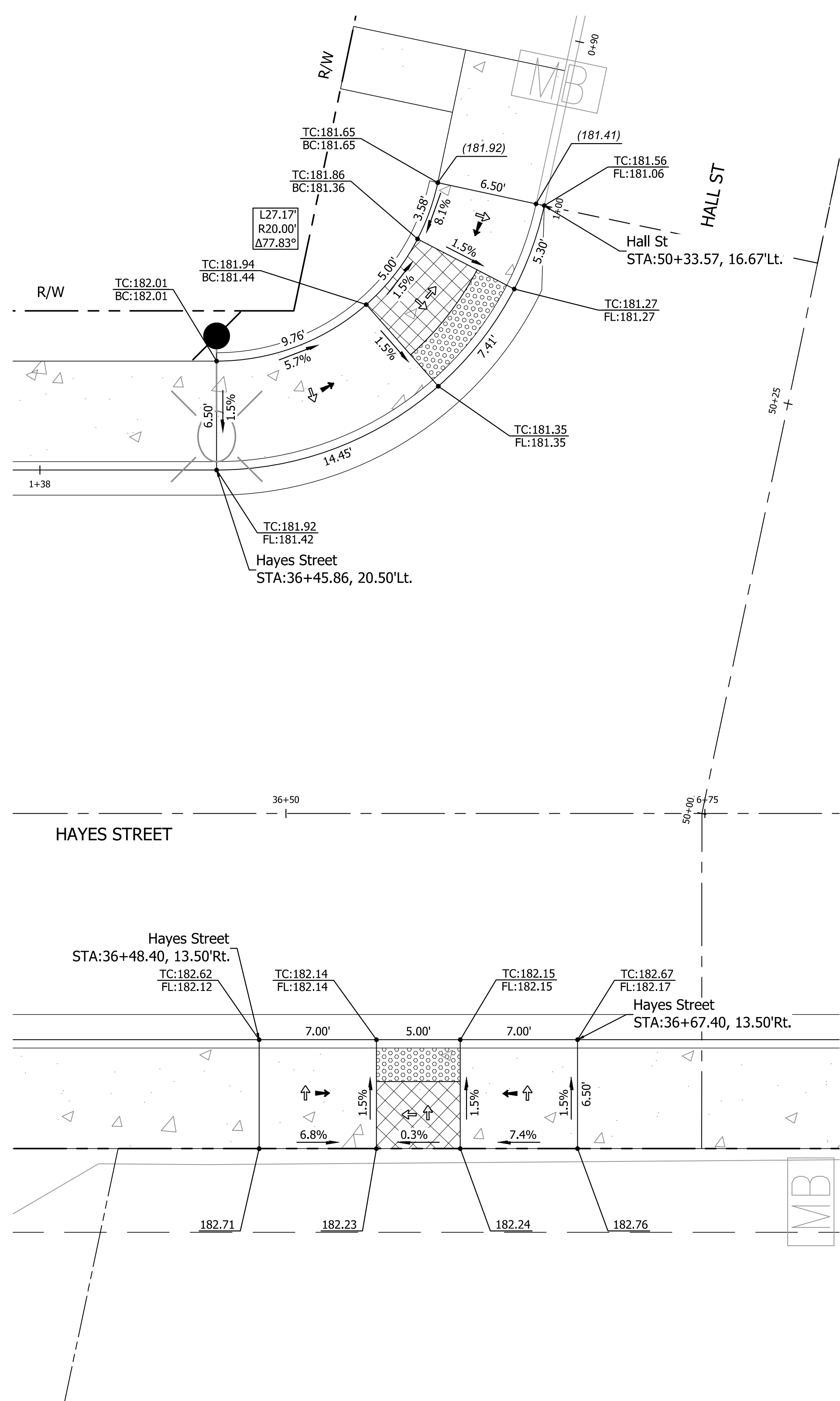

SIDEWALK RAMP GENERAL NOTES

- Contractor shall be responsible for meeting all Americans with disabilities (ADA) requirements as defined by the public rights-of-way accessibility guidelines (PROWAG). Details and dimensions shown are approximate only and intended as a guide for initial layout purposes only and are not complete. Contractor shall take all necessary field measurements and otherwise verify all dimensions to meet ada requirements. Should any error or inconsistency exist the contractor shall not proceed with the work affected until reported to the engineer for clarification or correction.
- Protect freshly poured concrete from vandalism or other damage for a minimum of twenty-four (24) hours or until cured enough to support typical use, whichever is longer. Any concrete damaged by vandalism or other causes shall be replaced at no cost to the city.
- See Standard ODOT Details RD902, RD904, RD906, and RD920 for Curb Ramp Construction on Sheet 2B-6

LEGEND

- Detectable Warning Surface
- Turning Space
- Slope 1.5% (max. 2.0% Finished Surface Slope) (normal Sidewalk Cross Slope)
- Slope 7.5% (max. 8.3% Finished Surface Slope)

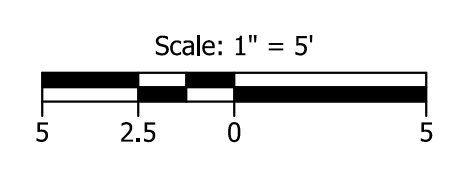
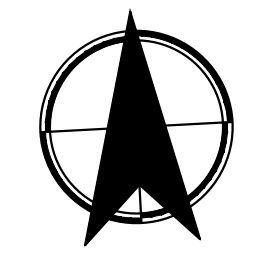

ABBREVIATION

- TC = Top of Curb Elevation
- BC = Bottom of Curb Elevation
- FL = Flow Line
- () = Match Extg. Grade

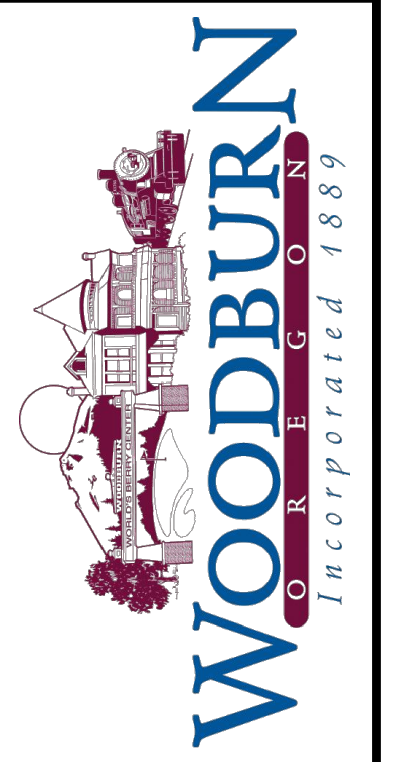

KITTELSON & ASSOCIATES
 851 SW 6TH AVENUE, SUITE 600
 PORTLAND, OR 97204
 P 503.228.5230 F 503.273.8169

NO.	DATE	REVISION	APP'D
0	05/25/22	ISSUE FOR CONSTRUCTION	FSW

Submission Date: 03/07/2022
 Drawn: JCB/RMM Designed: NRS/JBK Checked: FSW

PROJECT NO. 2015-001-20

W. Hayes Street Improvements
 Cascade Avenue to Settlemier Avenue
 DETAILED GRADING PLAN
 HALL STREET CURB RAMPS

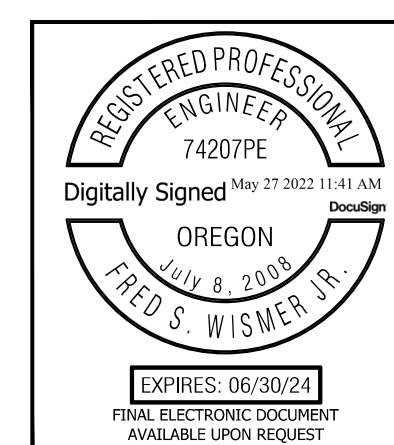

SHEET NO. 2E-6A

Plot Stamp: 5/27/2022 11:19:10 AM - Fred Wismer
 File: H:\24\24512 - W. Hayes Street\design\CD\CD-Detailed-Grading-Plans-24512.dwg

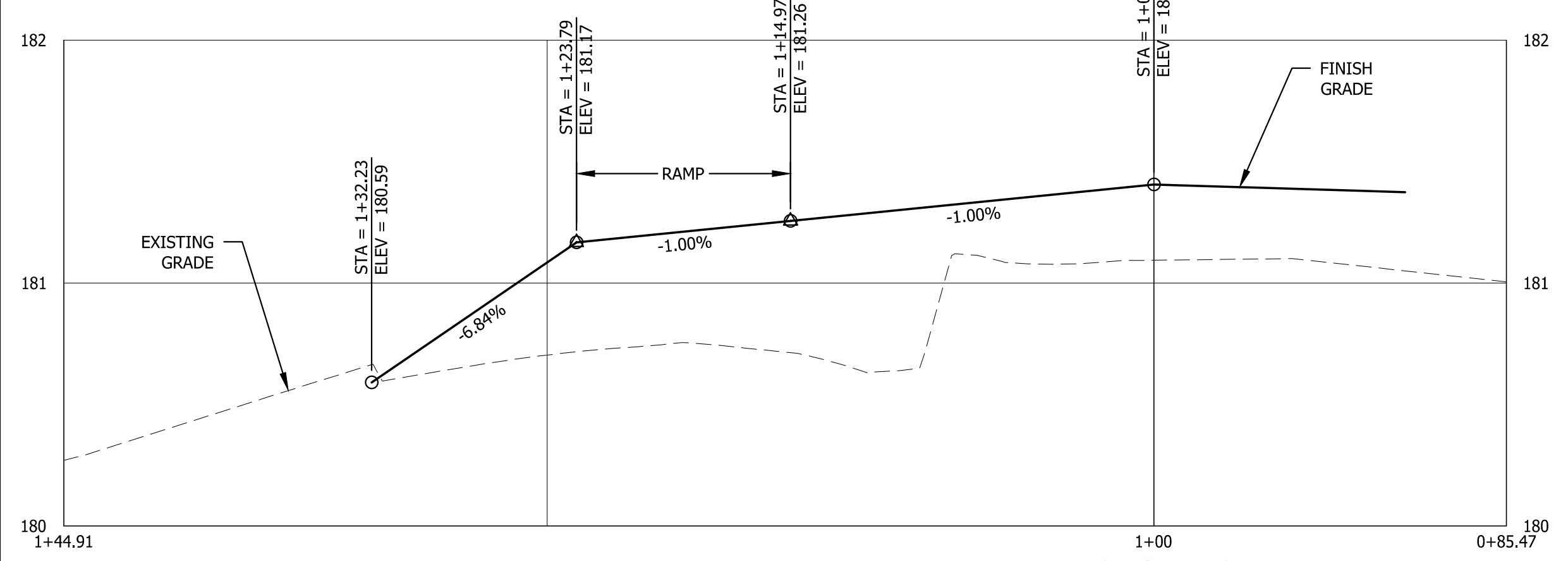

NE Curb Return

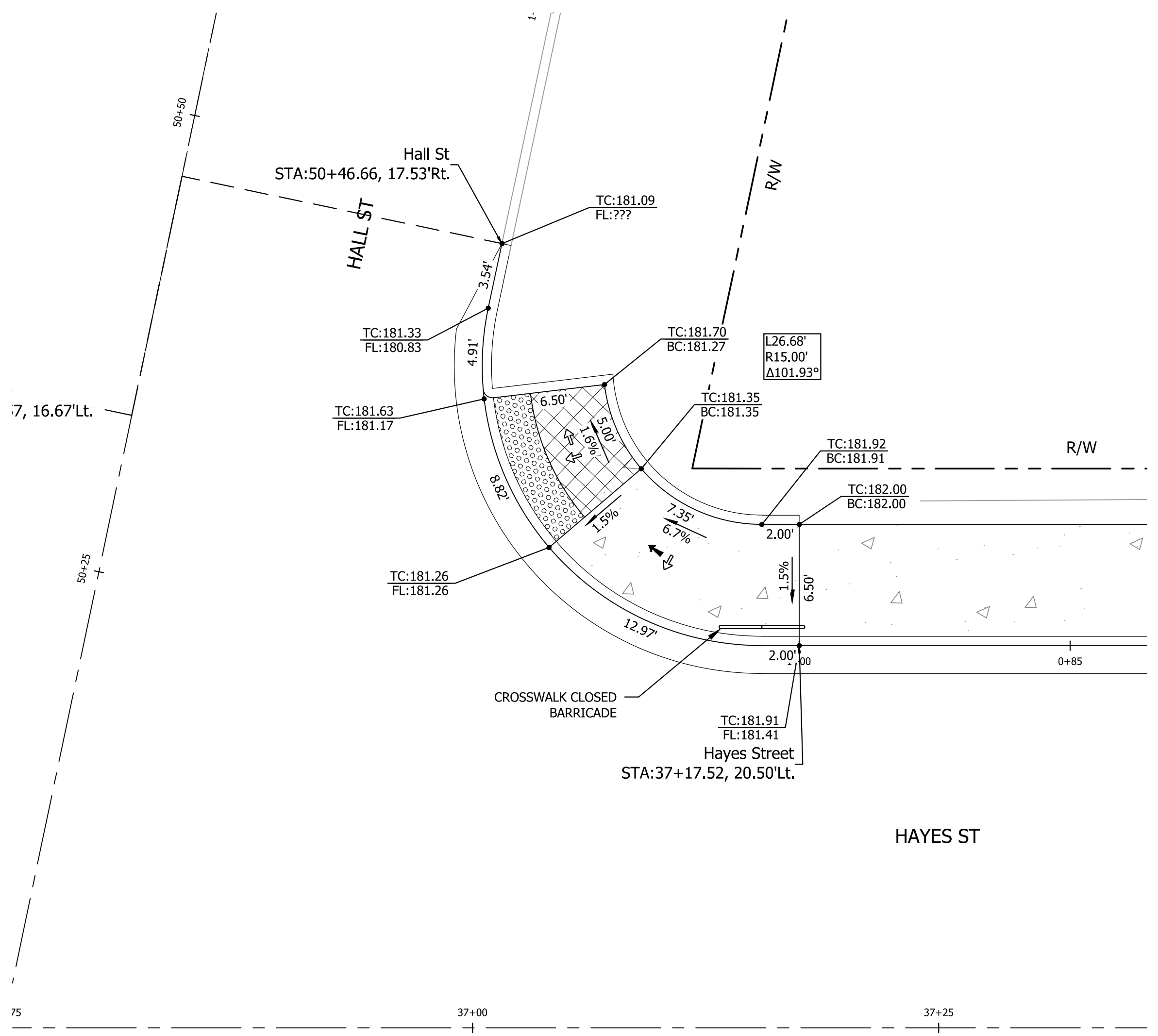

SIDEWALK RAMP GENERAL NOTES

- Contractor shall be responsible for meeting all Americans with disabilities (ADA) requirements as defined by the public rights-of-way accessibility guidelines (PROWAG). Details and dimensions shown are approximate only and intended as a guide for initial layout purposes only and are not complete. Contractor shall take all necessary field measurements and otherwise verify all dimensions to meet ada requirements. Should any error or inconsistency exist the contractor shall not proceed with the work affected until reported to the engineer for clarification or correction.
- Protect freshly poured concrete from vandalism or other damage for a minimum of twenty-four (24) hours or until cured enough to support typical use, whichever is longer. Any concrete damaged by vandalism or other causes shall be replaced at no cost to the city.
- See Standard ODOT Details RD902, RD904, RD906, and RD920 for Curb Ramp Construction on Sheet 2B-6

LEGEND

- Detectable Warning Surface
- Turning Space
- Slope 1.5%. (max. 2.0% Finished Surface Slope) (normal Sidewalk Cross Slope)
- Slope 7.5%. (max. 8.3% Finished Surface Slope)

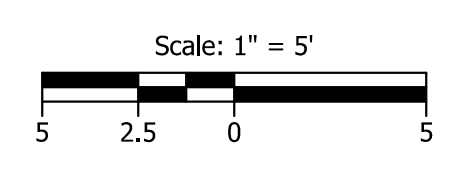
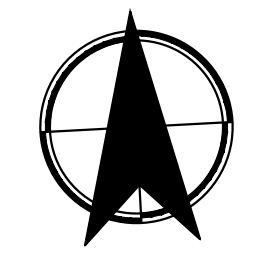

ABBREVIATION

- TC = Top of Curb Elevation
- BC = Bottom of Curb Elevation
- FL = Flow Line
- () = Match Extg. Grade

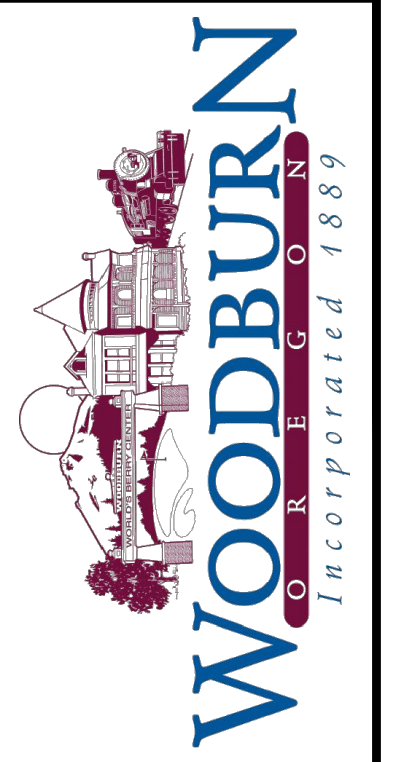

KITTELSON & ASSOCIATES
 851 SW 6TH AVENUE, SUITE 600
 PORTLAND, OR 97204
 P 503.228.5230 F 503.273.8169

NO.	DATE	REVISION	APP'D
0	05/25/22	ISSUE FOR CONSTRUCTION	FSW

Submission Date: 03/07/2022

Drawn: JCB/RMM
 Designed: NRS/JBK
 Checked: FSW

PROJECT NO. 2015-001-20

W. Hayes Street Improvements
 Cascade Avenue to Settlemier Avenue
 DETAILED GRADING PLAN
 HALL STREET CURB RAMPS

SHEET NO. 2E-6B

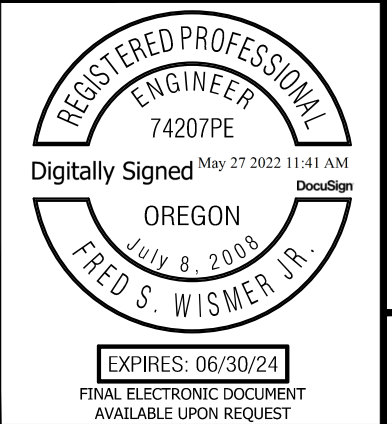

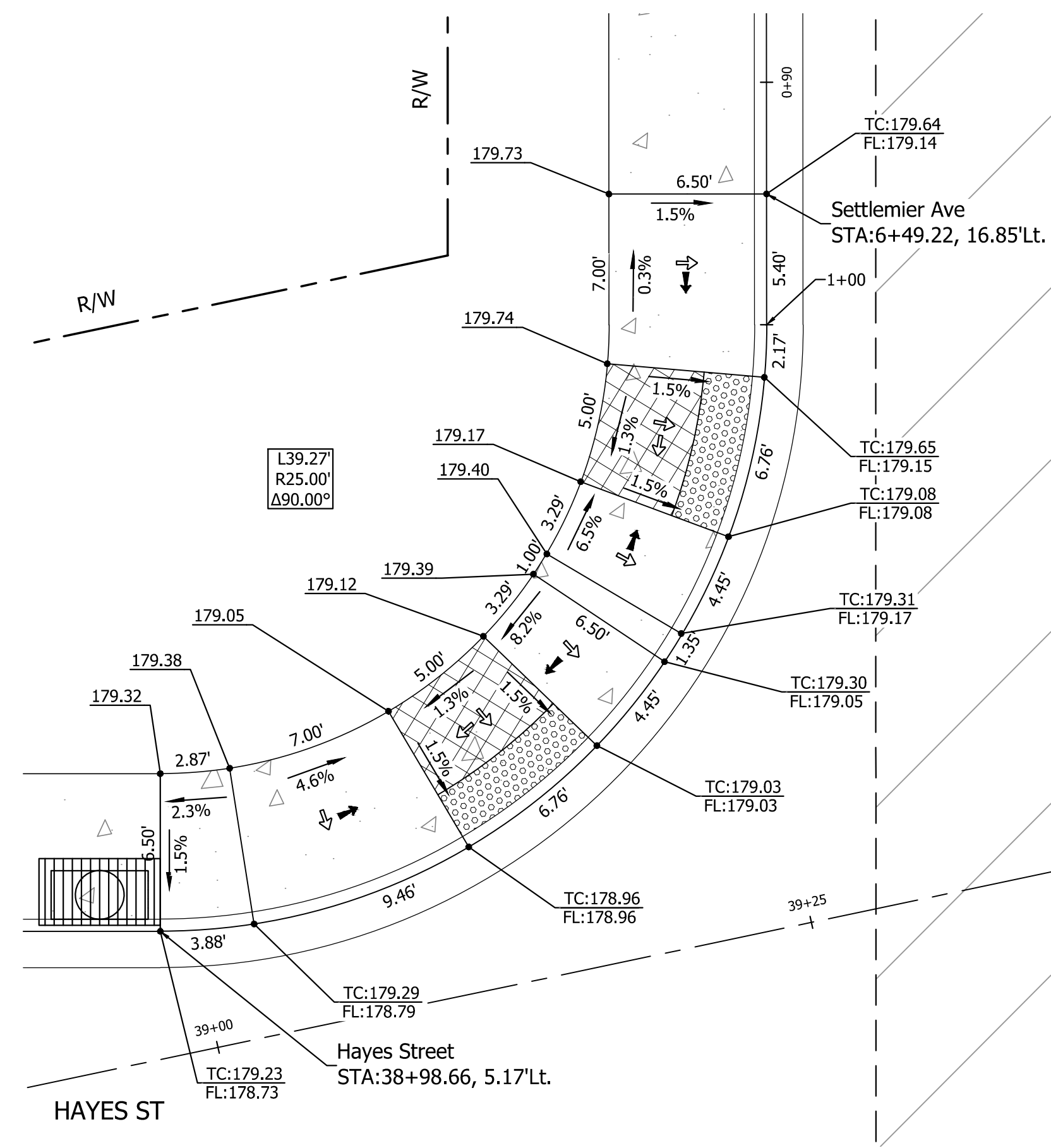

SETTLEMEIR AVE

NW Curb Return

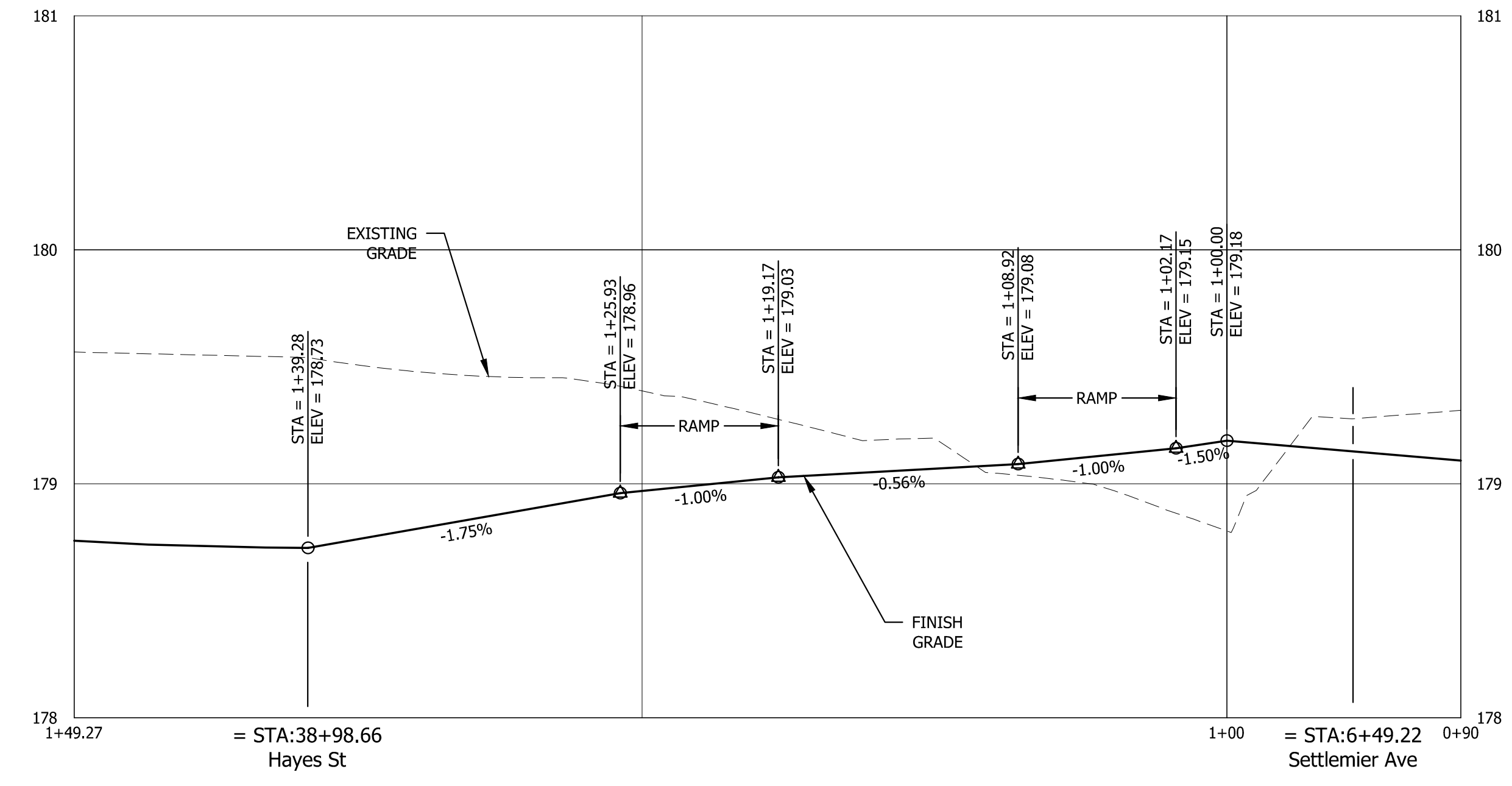

SIDEWALK RAMP GENERAL NOTES

- Contractor shall be responsible for meeting all Americans with disabilities (ADA) requirements as defined by the public rights-of-way accessibility guidelines (PROWAG). Details and dimensions shown are approximate only and intended as a guide for initial layout purposes only and are not complete. Contractor shall take all necessary field measurements and otherwise verify all dimensions to meet ada requirements. Should any error or inconsistency exist the contractor shall not proceed with the work affected until reported to the engineer for clarification or correction.
- Protect freshly poured concrete from vandalism or other damage for a minimum of twenty-four (24) hours or until cured enough to support typical use, whichever is longer. Any concrete damaged by vandalism or other causes shall be replaced at no cost to the city.
- See Standard ODOT Details RD902, RD904, RD906, and RD920 for Curb Ramp Construction on Sheet 2B-6

LEGEND

- Detectable Warning Surface
- Turning Space
- Slope 1.5% (max. 2.0% Finished Surface Slope) (normal Sidewalk Cross Slope)
- Slope 7.5% (max. 8.3% Finished Surface Slope)

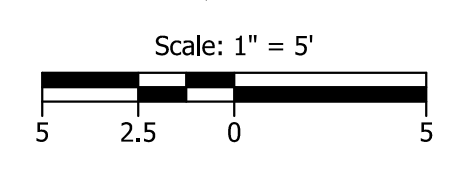
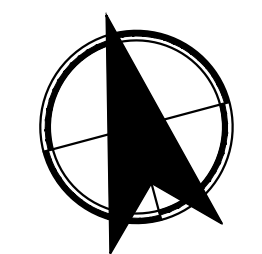

ABBREVIATION

- TC = Top of Curb Elevation
- BC = Bottom of Curb Elevation
- FL = Flow Line
- () = Match Extg. Grade

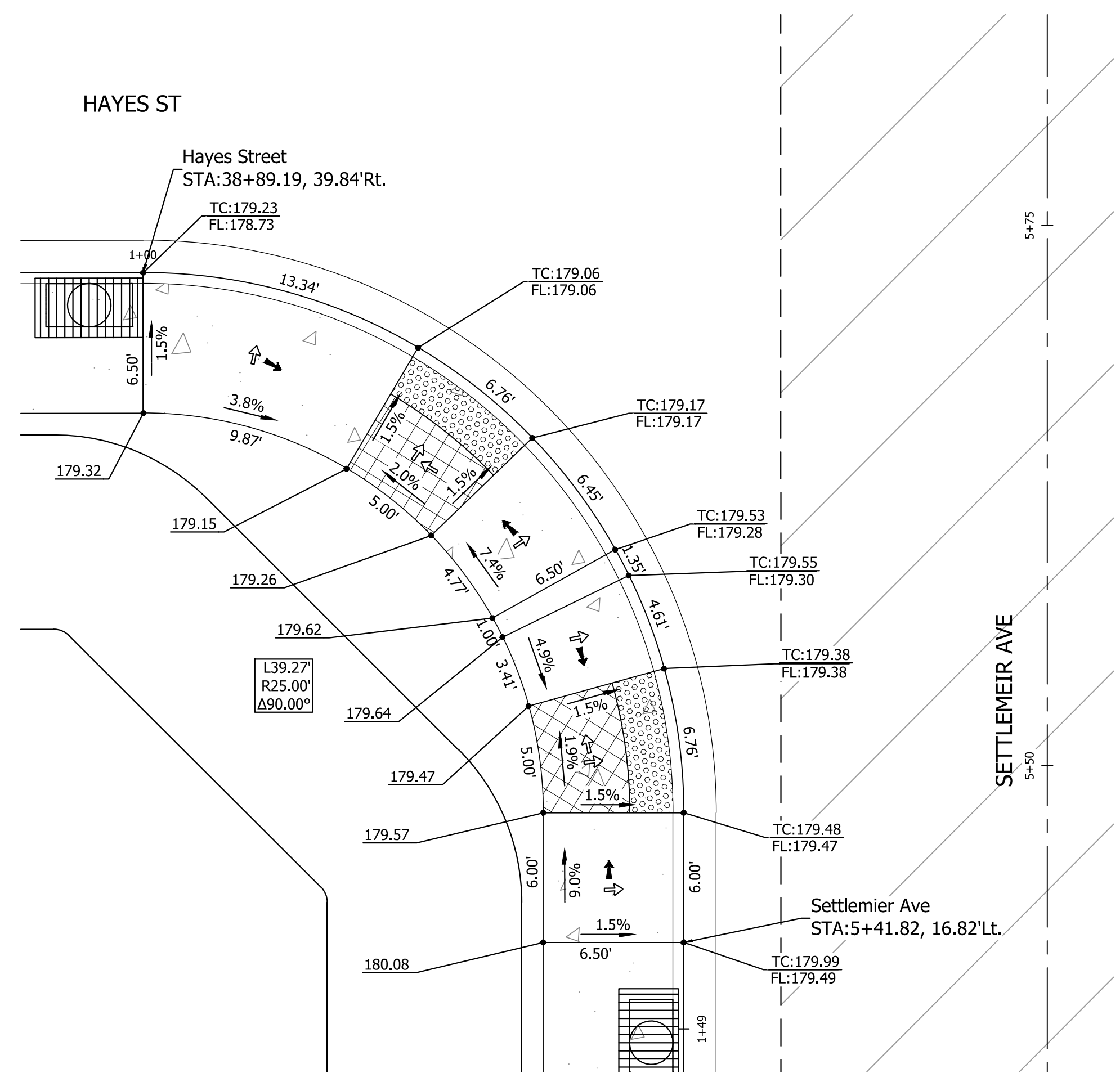

SETTLEMEIR AVE

SW Curb Return

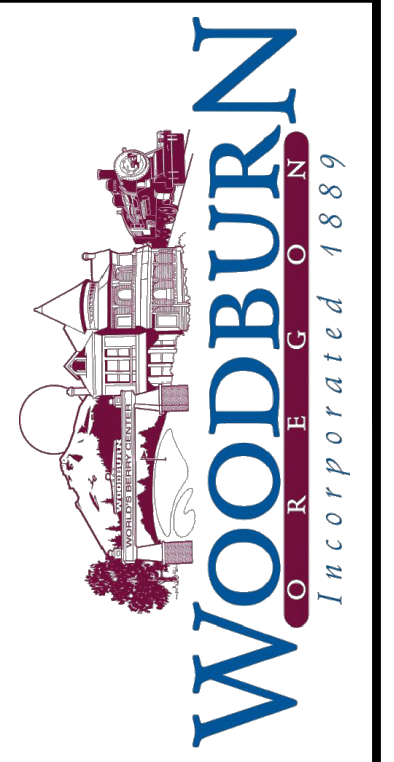
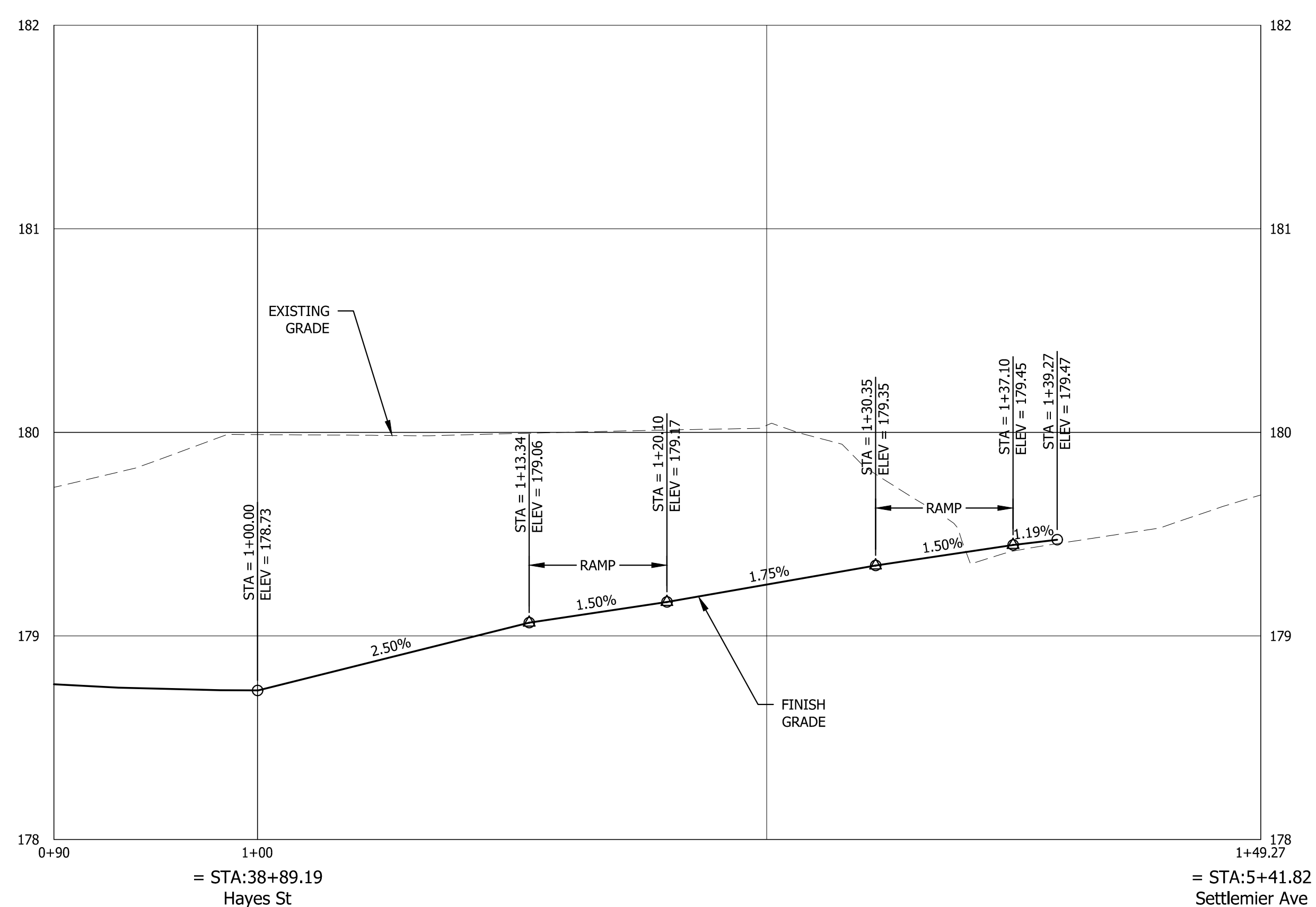

KITTELSON & ASSOCIATES
 851 SW 6TH AVENUE, SUITE 600
 PORTLAND, OR 97204
 P 503.228.5230 F 503.273.8169

NO.	DATE	REVISION	APP'D
0	05/25/22	ISSUE FOR CONSTRUCTION	FSW

Submission Date: 03/07/2022
 Drawn: JCB/RMM
 Designed: NRS/JBK
 Checked: FSW

PROJECT NO. 2015-001-20

W. Hayes Street Improvements
 Cascade Avenue to Settlemier Avenue
 DETAILED GRADING PLAN
 SETTLEMEIR AVE

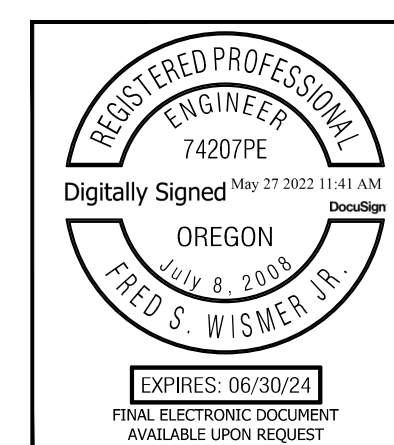

SHEET NO. 2E-7A

Plot Stamp: 5/27/2022 11:19:48 AM - Fred Wismer
 File: H:\24\24512 - W. Hayes Street\design\CD\CD-Detailed-Grading-Plans-24512.dwg

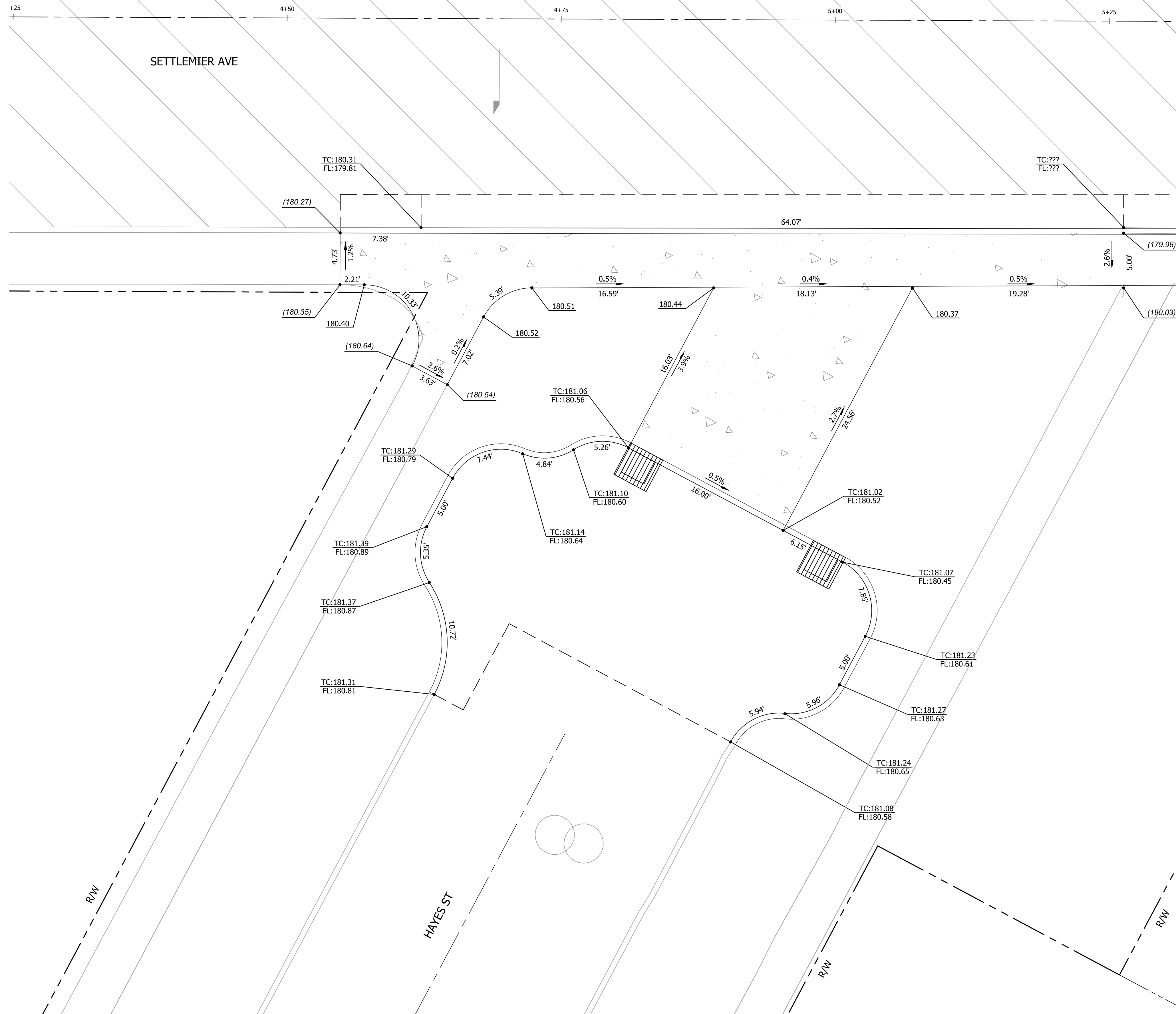

SIDEWALK RAMP GENERAL NOTES

- Contractor shall be responsible for meeting all Americans with disabilities (ADA) requirements as defined by the public rights-of-way accessibility guidelines (PROWAG). Details and dimensions shown are approximate only and intended as a guide for initial layout purposes only and are not complete. Contractor shall take all necessary field measurements and otherwise verify all dimensions to meet ADA requirements. Should any error or inconsistency exist the contractor shall not proceed with the work affected until reported to the engineer for clarification or correction.
- Protect freshly poured concrete from vandalism or other damage for a minimum of twenty-four (24) hours or until cured enough to support typical use, whichever is longer. Any concrete damaged by vandalism or other causes shall be replaced at no cost to the city.

LEGEND

- Detectable Warning Surface
- Turning Space
- Slope 1.5% (max. 2.0% Finished Surface Slope) (normal Sidewalk Cross Slope)
- Slope 7.5% (max. 8.3% Finished Surface Slope)

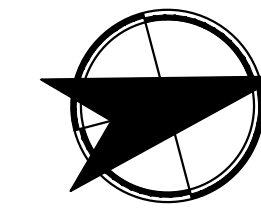

Scale: 1" = 5'
 5 2.5 0 5

ABBREVIATION

- TC = Top of Curb Elevation
- BC = Bottom of Curb Elevation
- FL = Flow Line
- () = Match Extg. Grade

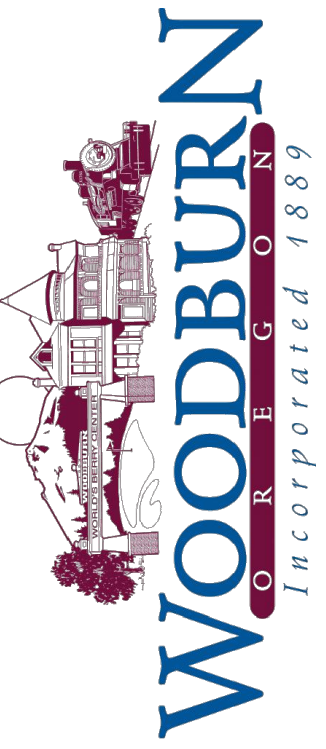

KITTELSON & ASSOCIATES

851 SW 6TH AVENUE, SUITE 600
 PORTLAND, OR 97204
 P 503.228.5230 F 503.273.8169

NO.	DATE	REVISION	APP'D.
0	05/25/22	ISSUE FOR CONSTRUCTION	FSW

Submission Date: 03/07/2022

Drawn: JCB/RMM Designed: NRS/JBK Checked: FSW

PROJECT NO. 2015-001-20

W. Hayes Street Improvements
 Cascade Avenue to Settlemier Avenue
 DETAILED GRADING PLAN
 HAYES STREET CUL-DE-SAC

SHEET NO. 2E-8

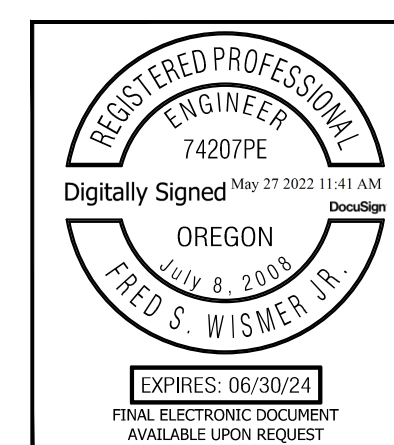

Plot Stamp: 5/27/2022 11:20:22 AM - Fred Wismer
 File: H:\24\24512 - W. Hayes Street\design\CD\CD-Detailed-Grading-Plans-24512.dwg

Plot Stamp: 5/27/2022 11:20:49 AM - Fred Wismer
 File: H:\24\24512 - W. Hayes Street\design\CD\CD-Detailed-Grading-Plans-DRWYS.dwg

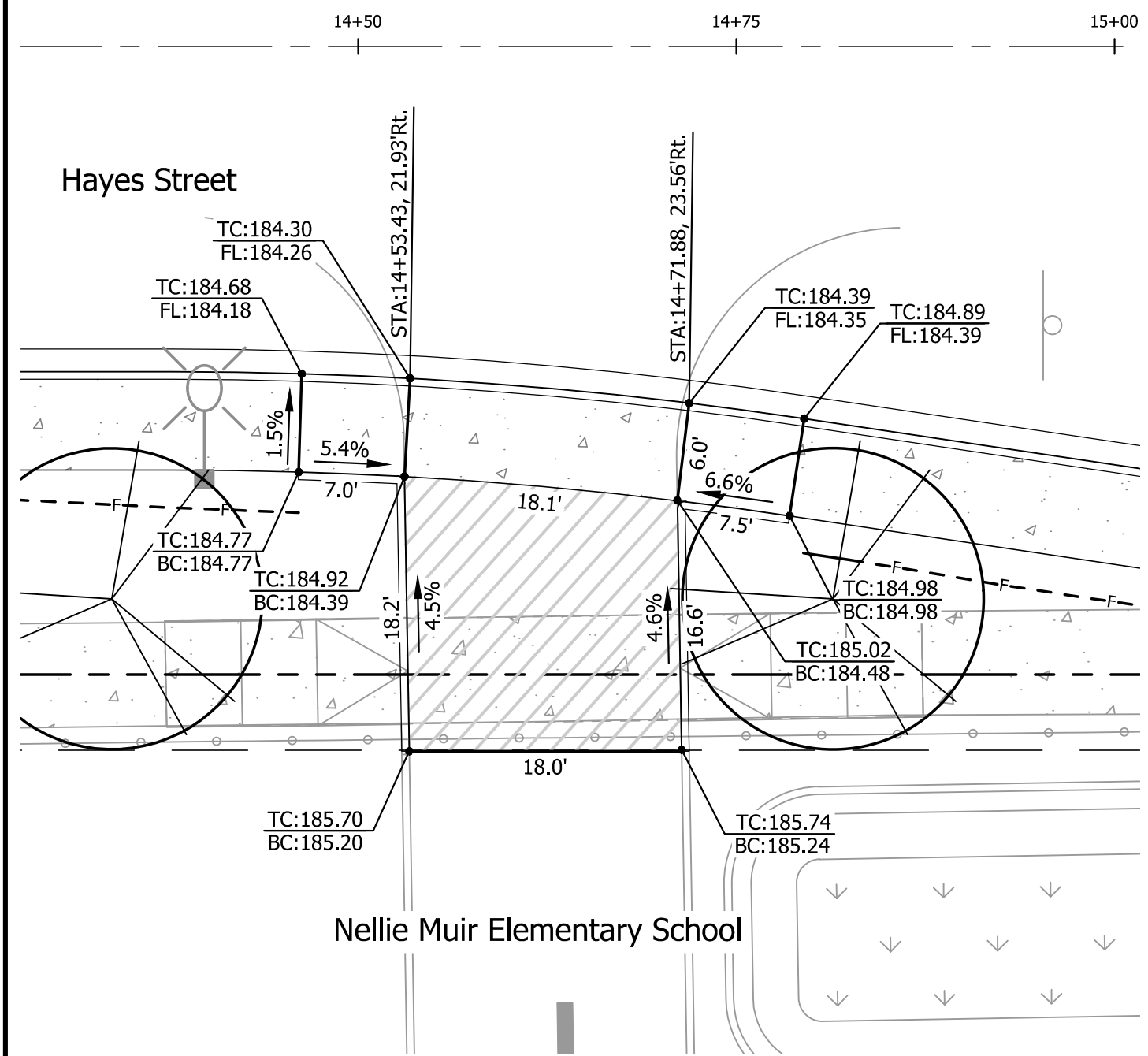

4A 1800 W Hayes St
 SCALE: 1" = 10'

Driveway Construction Table

Throat Width (ft)	Width w/Wings (ft)	Driveway Area Material	Driveway Area (Sq. Ft) (D/W)	Approach Area Material	Approach Area (Sq. Ft) (D/W)
18.1	32.6	Concrete	197.6	Asphalt	314.4

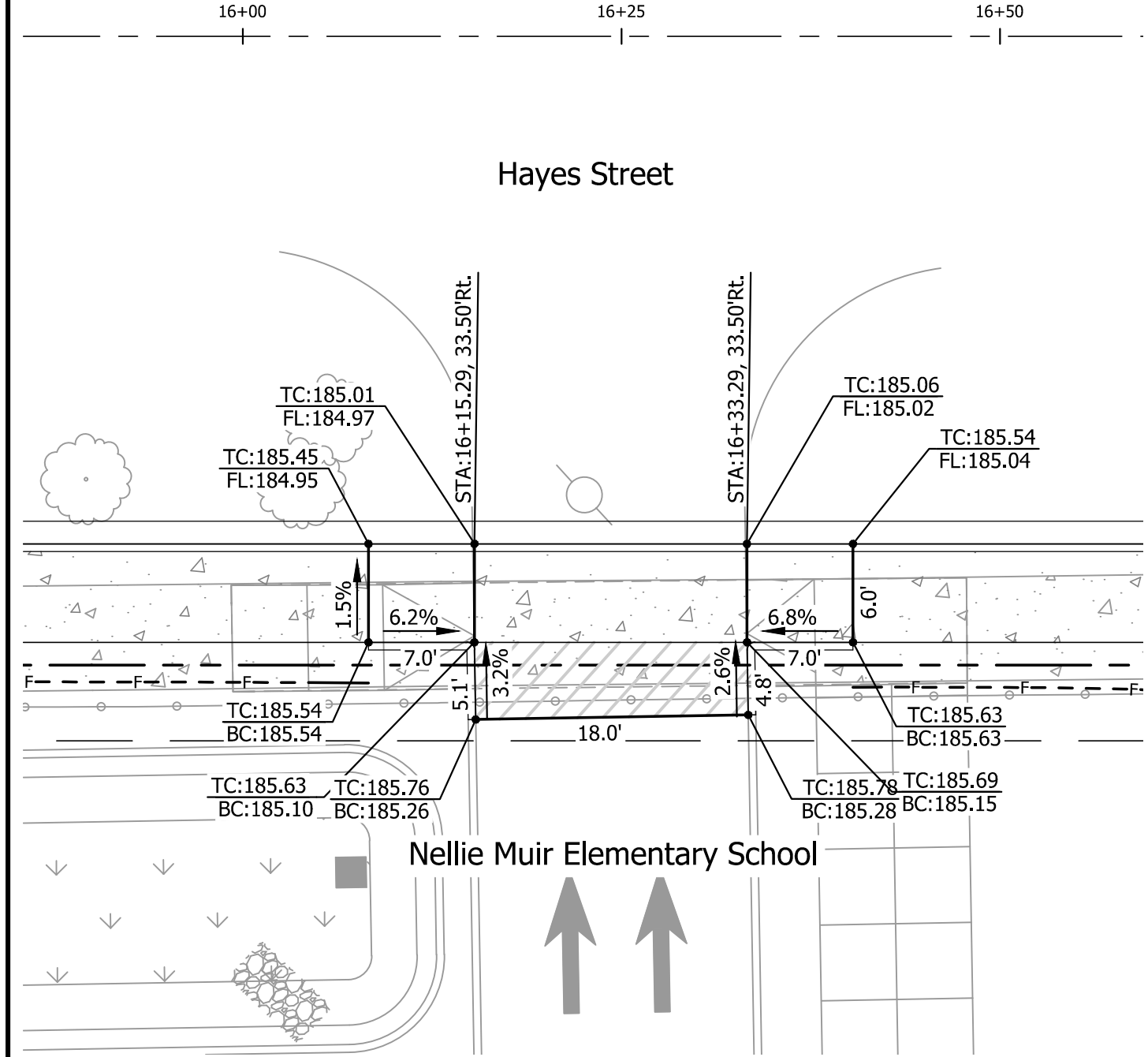

4B 1800 W Hayes St
 SCALE: 1" = 10'

Driveway Construction Table

Throat Width (ft)	Width w/Wings (ft)	Driveway Area Material	Driveway Area (Sq. Ft) (D/W)	Approach Area Material	Approach Area (Sq. Ft) (D/W)
18.0	32.0	Concrete	192.0	Asphalt	89.1

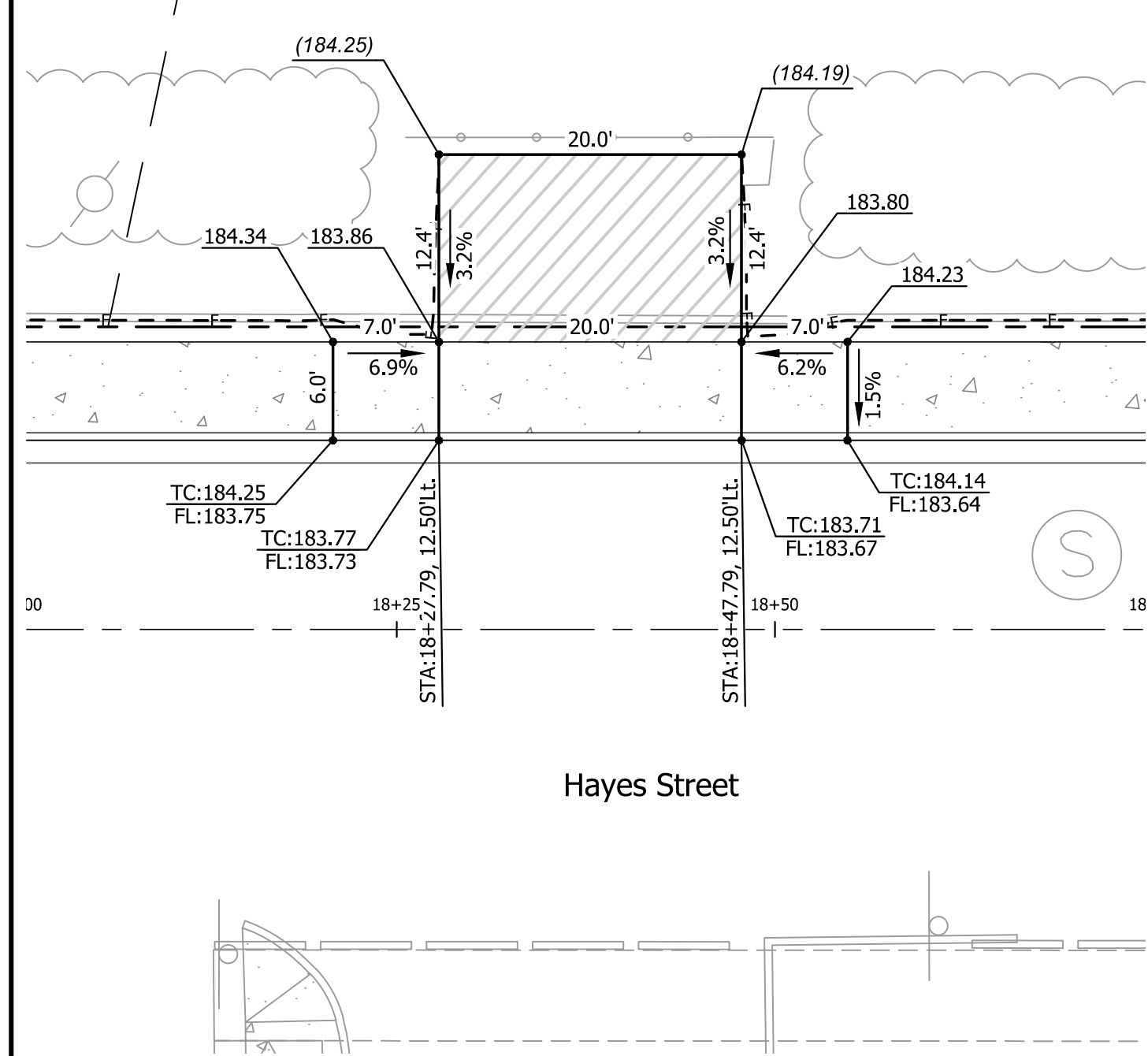

3A Mobile Home Park
 SCALE: 1" = 10'

Driveway Construction Table

Throat Width (ft)	Width w/Wings (ft)	Driveway Area Material	Driveway Area (Sq. Ft) (D/W)	Approach Area Material	Approach Area (Sq. Ft) (D/W)
20.0	34.0	Concrete	204.0	Asphalt	248.0

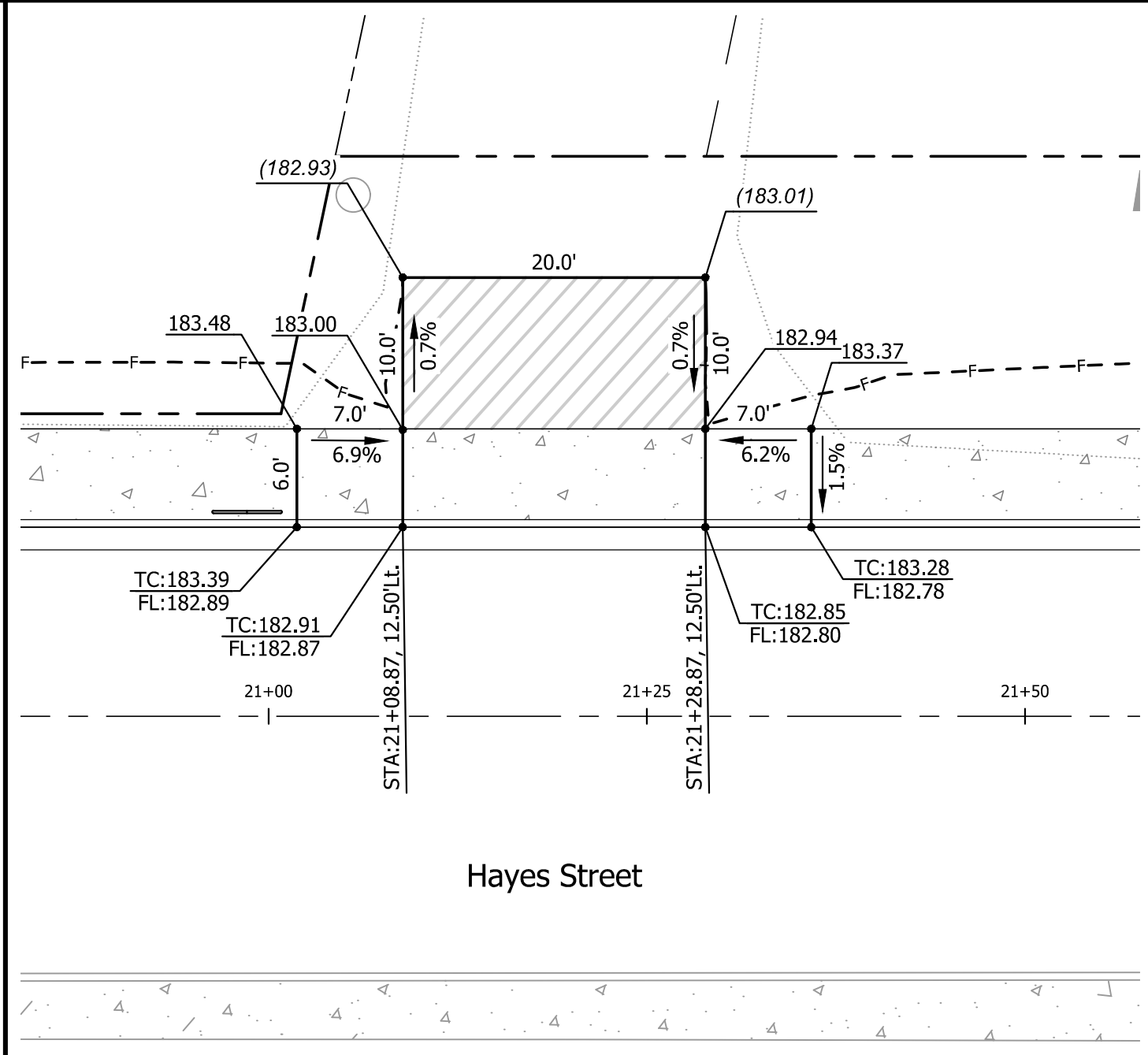

1A 1767 W Hayes St
 SCALE: 1" = 10'

Driveway Construction Table

Throat Width (ft)	Width w/Wings (ft)	Driveway Area Material	Driveway Area (Sq. Ft) (D/W)	Approach Area Material	Approach Area (Sq. Ft) (D/W)
20.0	27.0	Concrete	162.0	Asphalt	186.5



1B 1645-1655 W Hayes St
 SCALE: 1" = 10'

Driveway Construction Table

Throat Width (ft)	Width w/Wings (ft)	Driveway Area Material	Driveway Area (Sq. Ft) (D/W)	Approach Area Material	Approach Area (Sq. Ft) (D/W)
20.0	34.0	Concrete	204.0	Asphalt	200.0

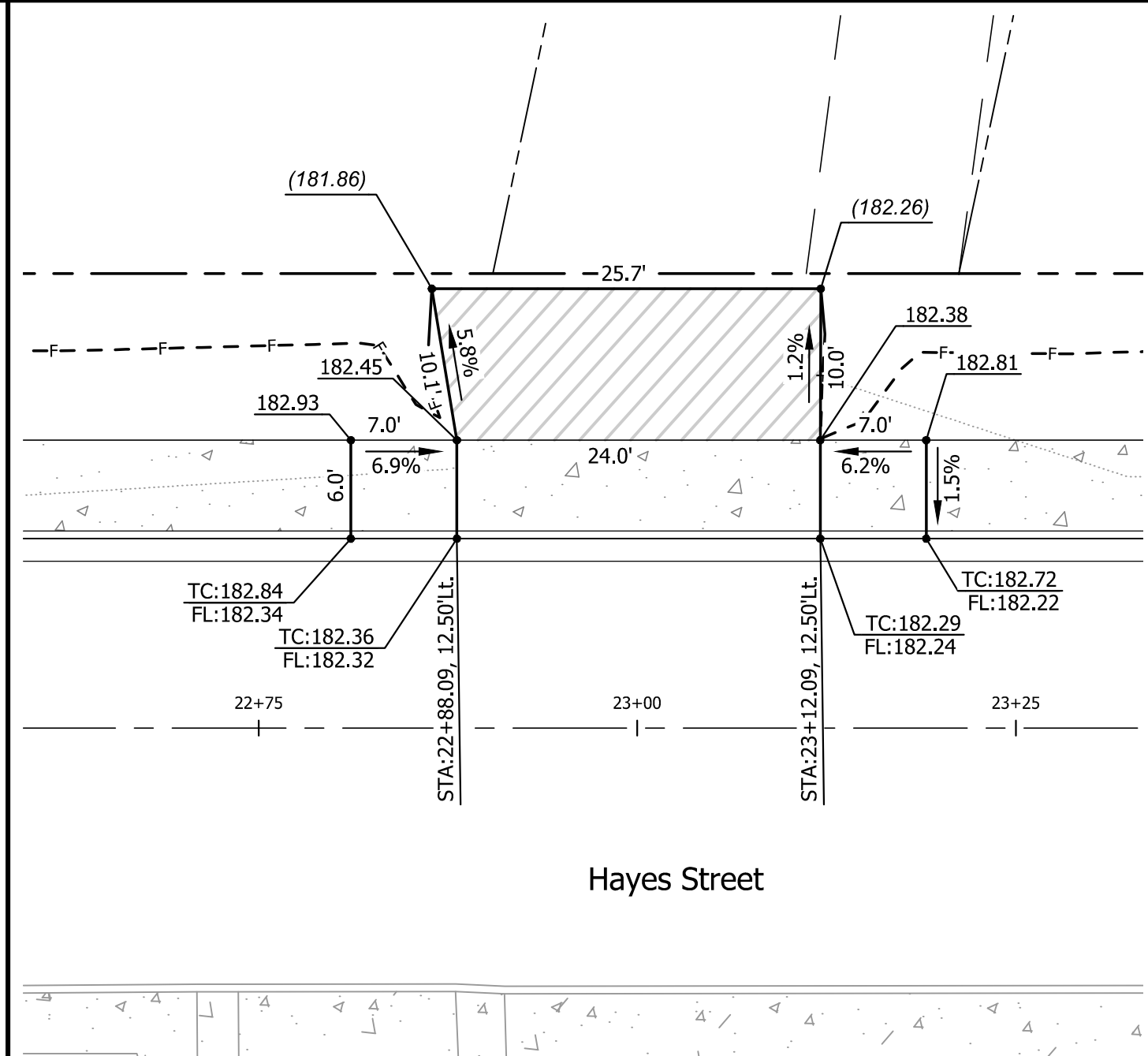

1C 1637 W Hayes St
 SCALE: 1" = 10'

Driveway Construction Table

Throat Width (ft)	Width w/Wings (ft)	Driveway Area Material	Driveway Area (Sq. Ft) (D/W)	Approach Area Material	Approach Area (Sq. Ft) (D/W)
24.0	38.0	Concrete	228.0	Asphalt	248.5

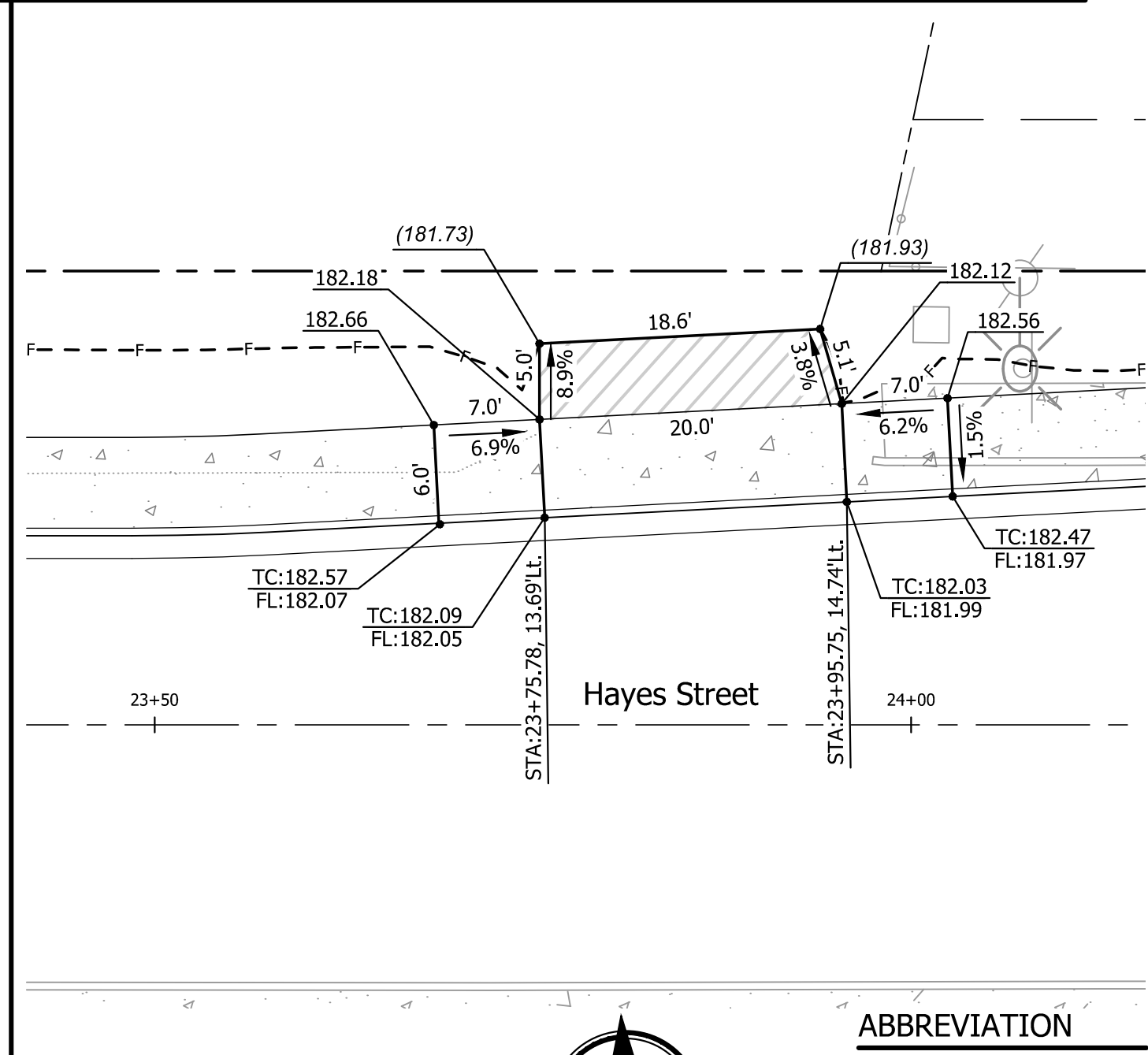

1D 1621 W Hayes St
 SCALE: 1" = 10'

Driveway Construction Table

Throat Width (ft)	Width w/Wings (ft)	Driveway Area Material	Driveway Area (Sq. Ft) (D/W)	Approach Area Material	Approach Area (Sq. Ft) (D/W)
20.0	34.0	Concrete	204.0	Asphalt	96.5

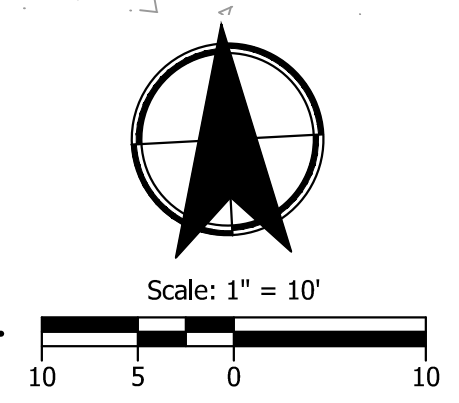

ABBREVIATION
 FL = Flowline Curb Elevation
 TC = Top of Curb Elevation
 (XXX.XX) = Match Extg. Grade
 XXX.XX = Finish Grade
 LX.XX' = Line Length
 CX.XX' = Curve Length

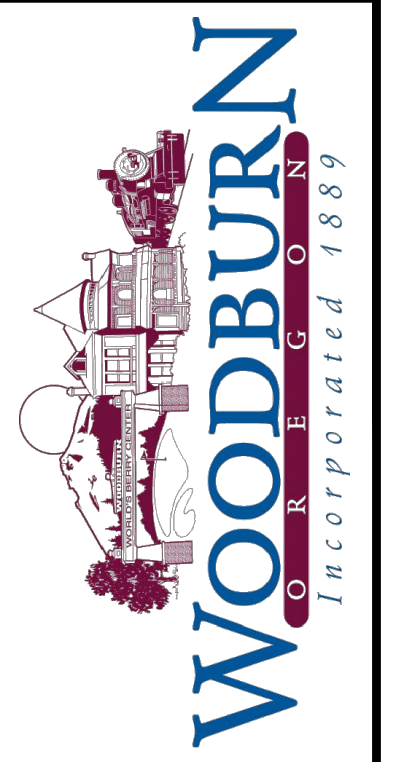
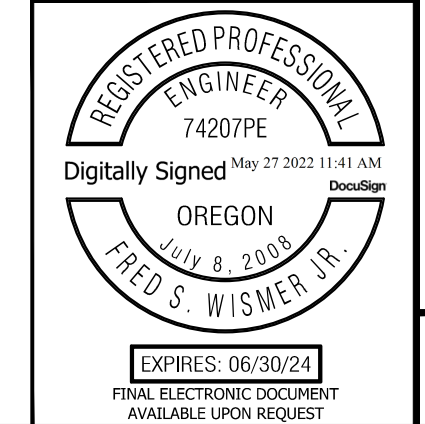

KITTELSON & ASSOCIATES
 851 SW 6TH AVENUE, SUITE 600
 PORTLAND, OR 97204
 P 503.228.5230 F 503.273.8169

NO.	DATE	REVISION	APP'D
0	05/25/22	ISSUE FOR CONSTRUCTION	FSW

Submission Date: 03/07/2022
 Drawn: JCB/RMM
 Designed: NRS/JBK
 Checked: FSW

PROJECT NO. 2015-001-20
W. Hayes Street Improvements
 Cascade Avenue to Settlemier Avenue
 DETAILED DRIVEWAY GRADING PLANS
 SHEET NO. 2E-10

NO.	DATE	REVISION
01	05/25/22	ISSUE FOR CONSTRUCTION
02		
03		
04		
05		
06		
07		
08		
09		
10		
11		
12		
13		
14		
15		
16		
17		
18		
19		
20		
21		
22		
23		
24		
25		
26		
27		
28		
29		
30		
31		
32		
33		
34		
35		
36		
37		
38		
39		
40		
41		
42		
43		
44		
45		
46		
47		
48		
49		
50		
51		
52		
53		
54		
55		
56		
57		
58		
59		
60		
61		
62		
63		
64		
65		
66		
67		
68		
69		
70		
71		
72		
73		
74		
75		
76		
77		
78		
79		
80		
81		
82		
83		
84		
85		
86		
87		
88		
89		
90		
91		
92		
93		
94		
95		
96		
97		
98		
99		
100		

Submission Date: 03/07/2022
 Drawn: JCB/RMM Designed: NRS/JBK Checked: FSW
 PROJECT NO. 2015-001-20

W. Hayes Street Improvements
 Cascade Avenue to Settlemier Avenue

DETAILED DRIVEWAY GRADING PLANS

SHEET NO. 2E-11

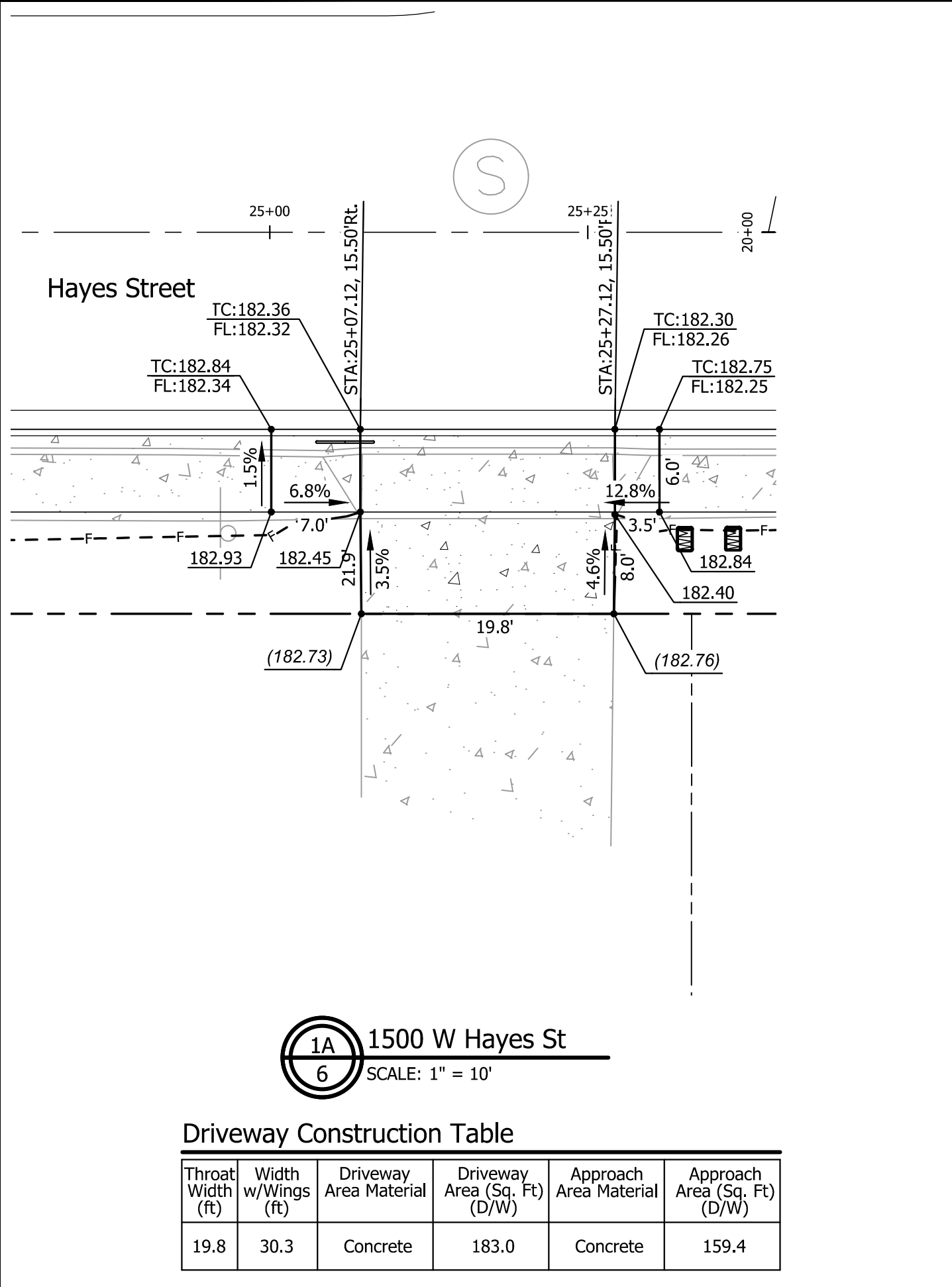

Driveway Construction Table

Throat Width (ft)	Width w/Wings (ft)	Driveway Area Material	Driveway Area (Sq. Ft) (D/W)	Approach Area Material	Approach Area (Sq. Ft) (D/W)
19.8	30.3	Concrete	183.0	Concrete	159.4

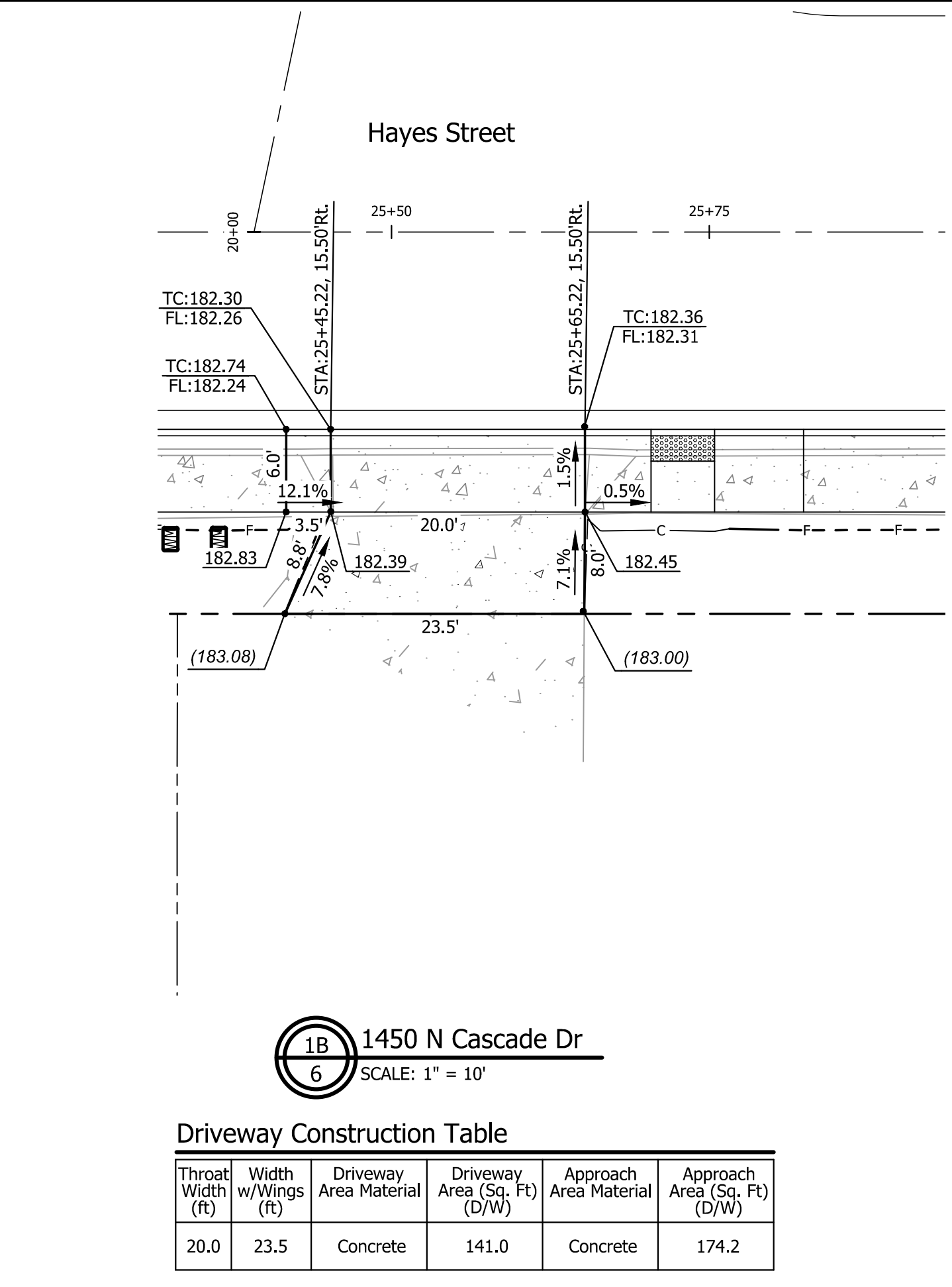

Driveway Construction Table

Throat Width (ft)	Width w/Wings (ft)	Driveway Area Material	Driveway Area (Sq. Ft) (D/W)	Approach Area Material	Approach Area (Sq. Ft) (D/W)
20.0	23.5	Concrete	141.0	Concrete	174.2

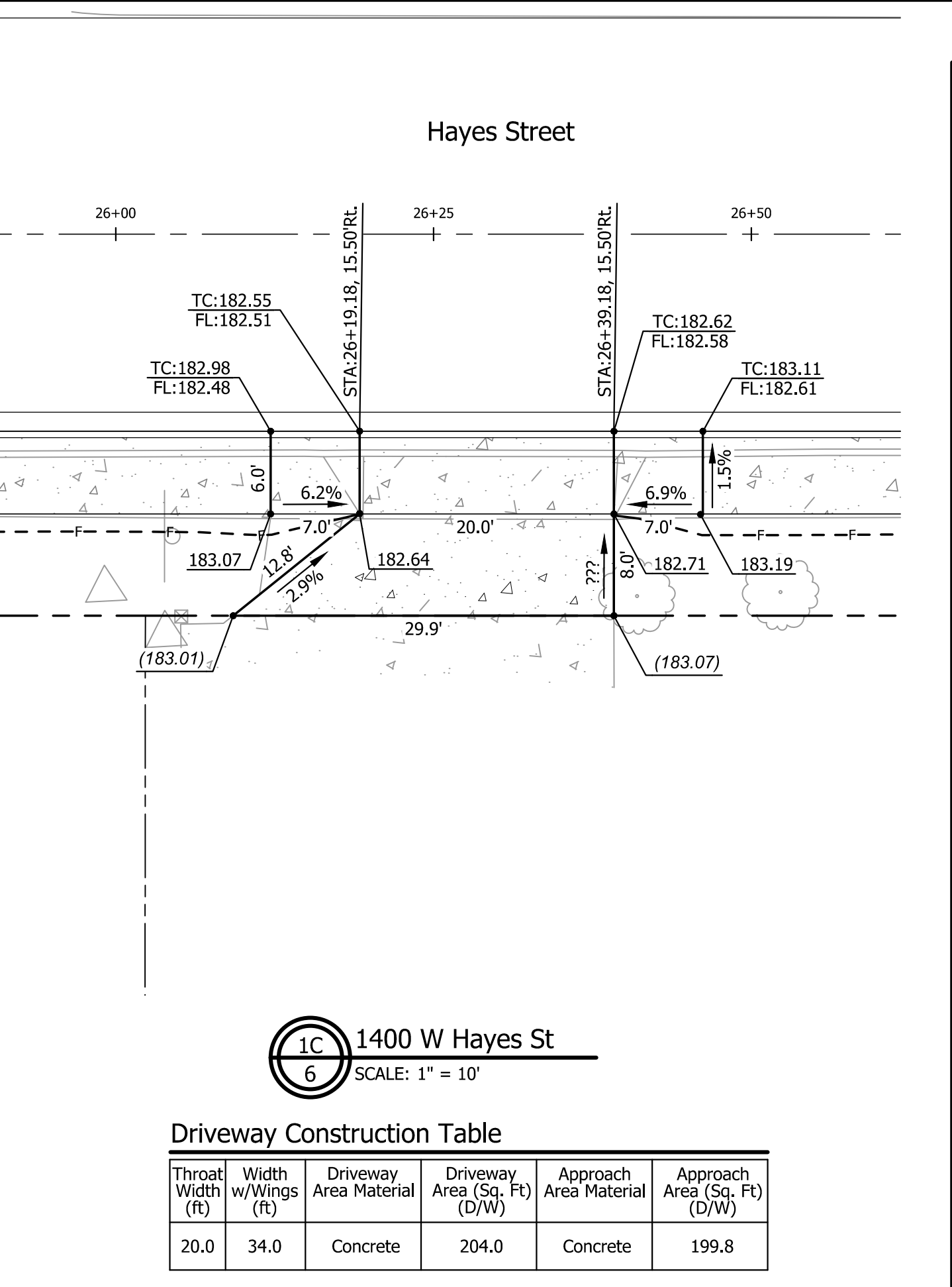

Driveway Construction Table

Throat Width (ft)	Width w/Wings (ft)	Driveway Area Material	Driveway Area (Sq. Ft) (D/W)	Approach Area Material	Approach Area (Sq. Ft) (D/W)
20.0	34.0	Concrete	204.0	Concrete	199.8

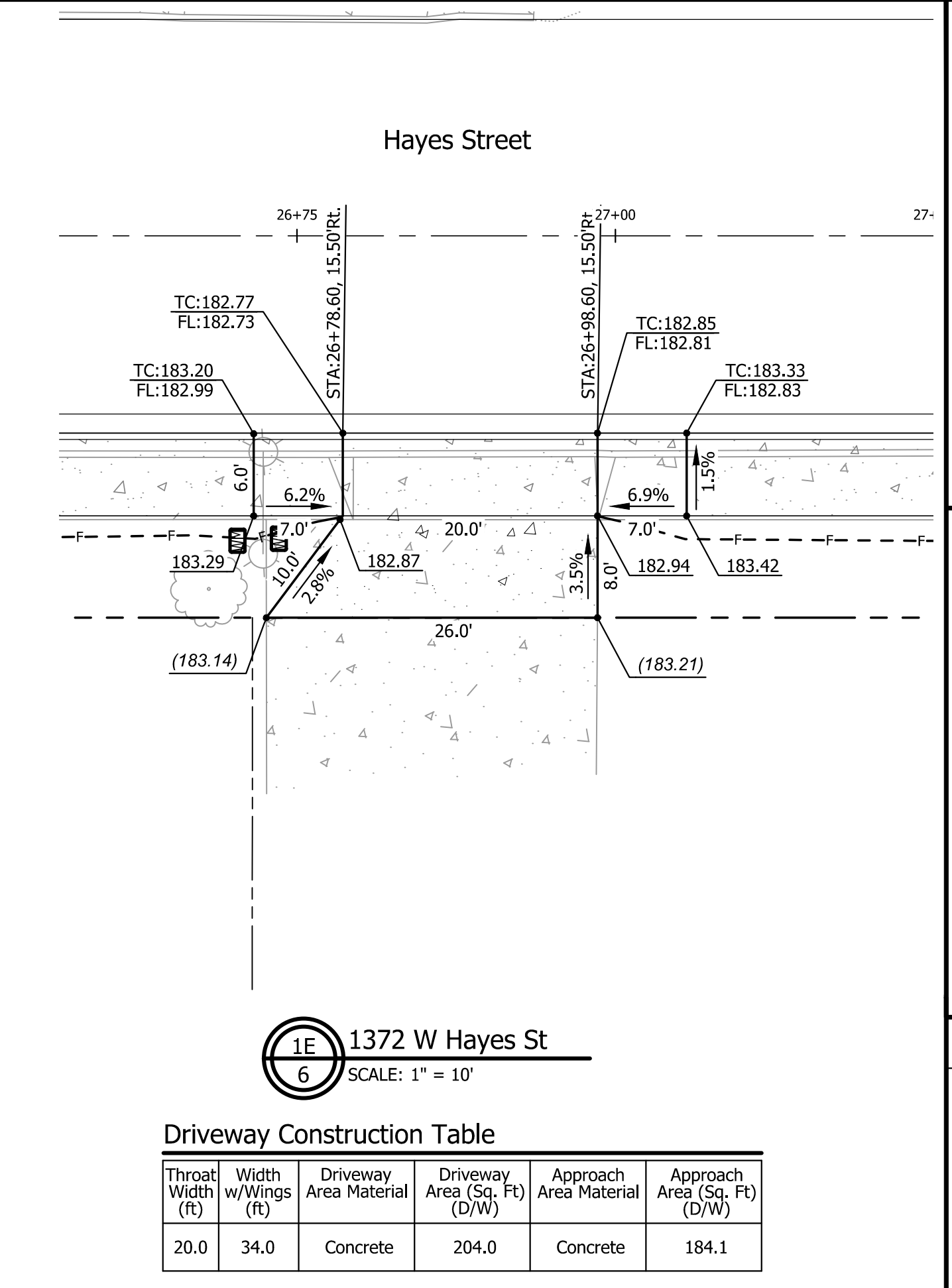

Driveway Construction Table

Throat Width (ft)	Width w/Wings (ft)	Driveway Area Material	Driveway Area (Sq. Ft) (D/W)	Approach Area Material	Approach Area (Sq. Ft) (D/W)
20.0	34.0	Concrete	204.0	Concrete	184.1

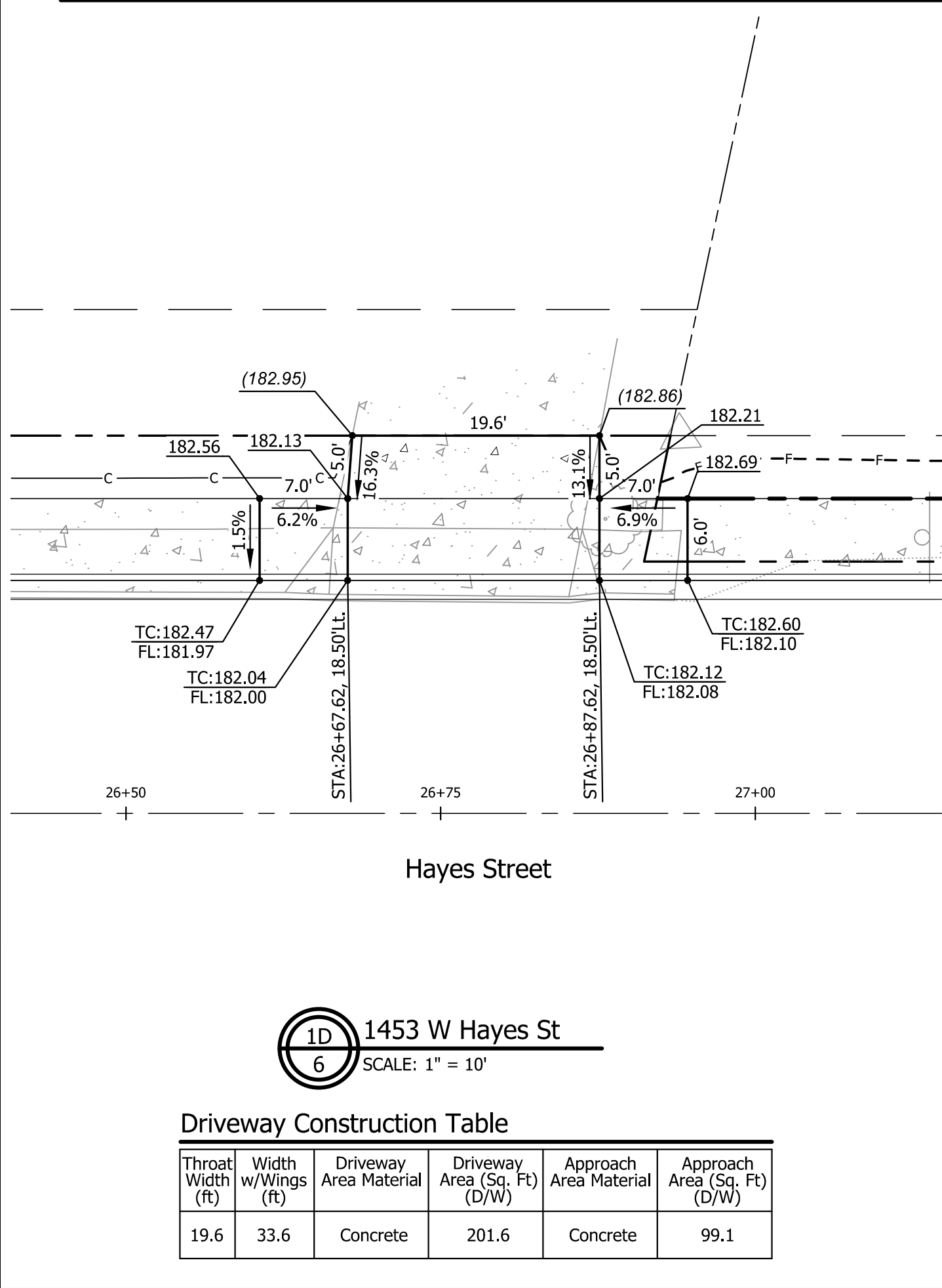

Driveway Construction Table

Throat Width (ft)	Width w/Wings (ft)	Driveway Area Material	Driveway Area (Sq. Ft) (D/W)	Approach Area Material	Approach Area (Sq. Ft) (D/W)
19.6	33.6	Concrete	201.6	Concrete	99.1

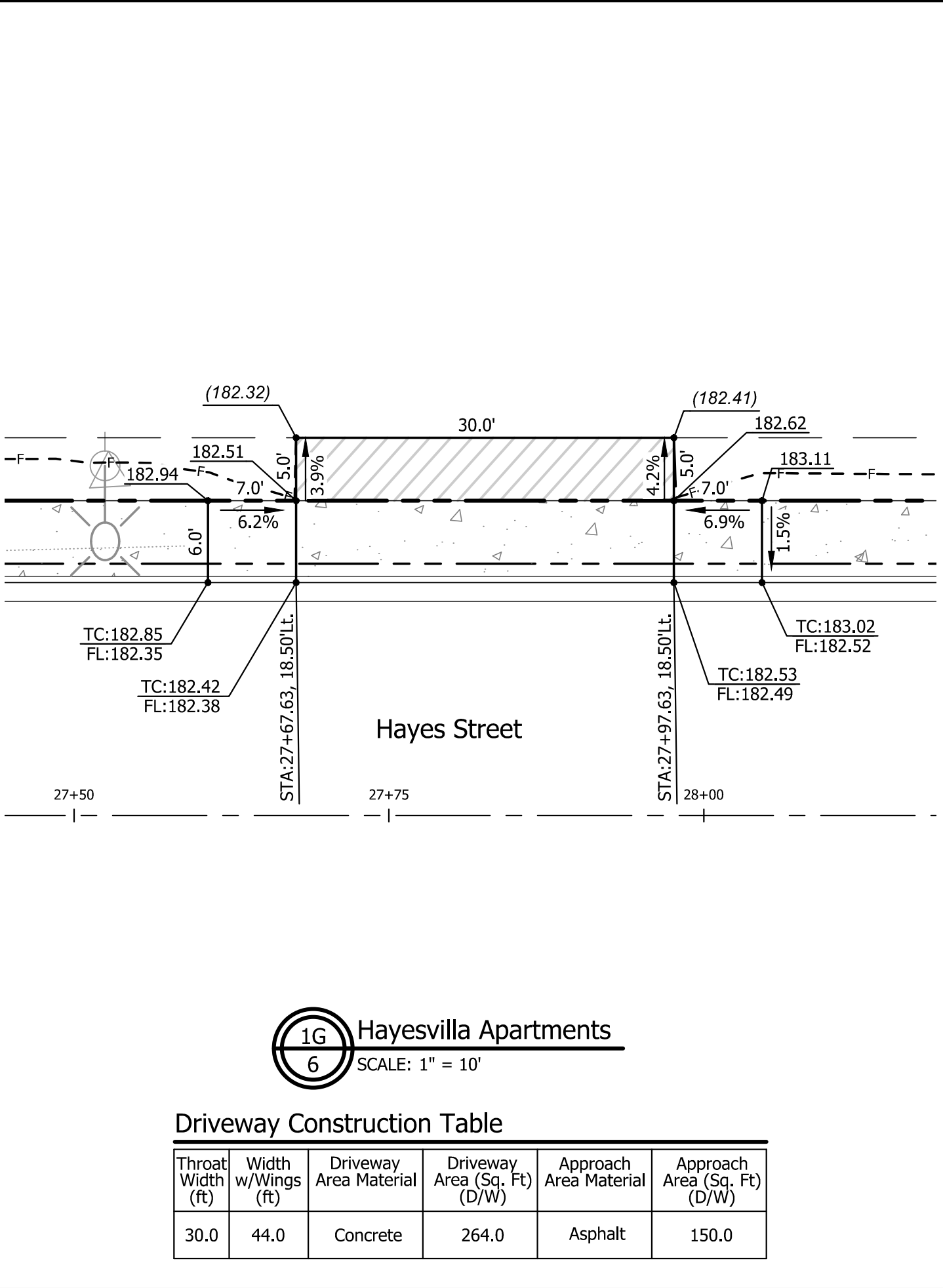

Driveway Construction Table

Throat Width (ft)	Width w/Wings (ft)	Driveway Area Material	Driveway Area (Sq. Ft) (D/W)	Approach Area Material	Approach Area (Sq. Ft) (D/W)
30.0	44.0	Concrete	264.0	Asphalt	150.0

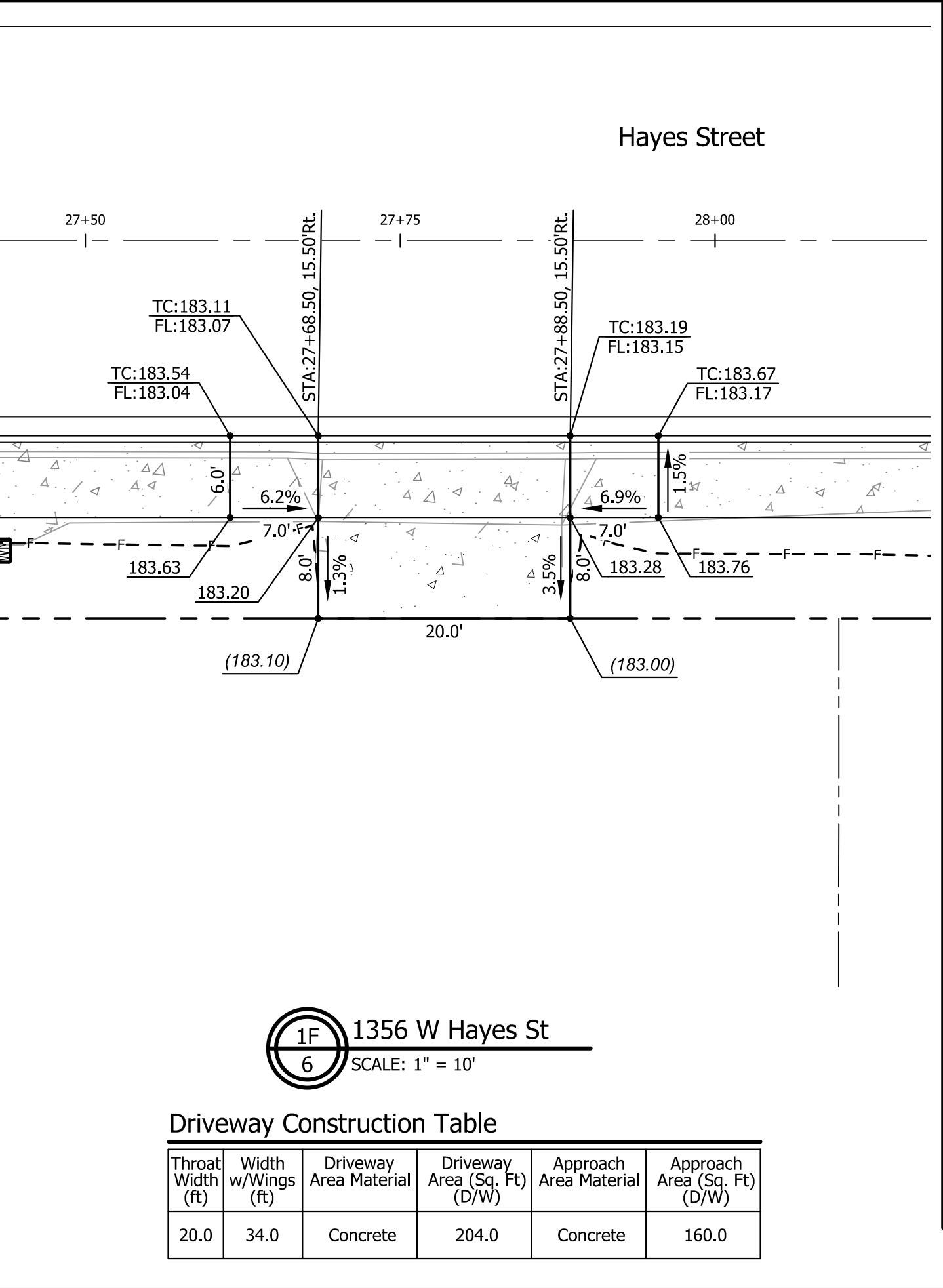

Driveway Construction Table

Throat Width (ft)	Width w/Wings (ft)	Driveway Area Material	Driveway Area (Sq. Ft) (D/W)	Approach Area Material	Approach Area (Sq. Ft) (D/W)
20.0	34.0	Concrete	204.0	Concrete	160.0

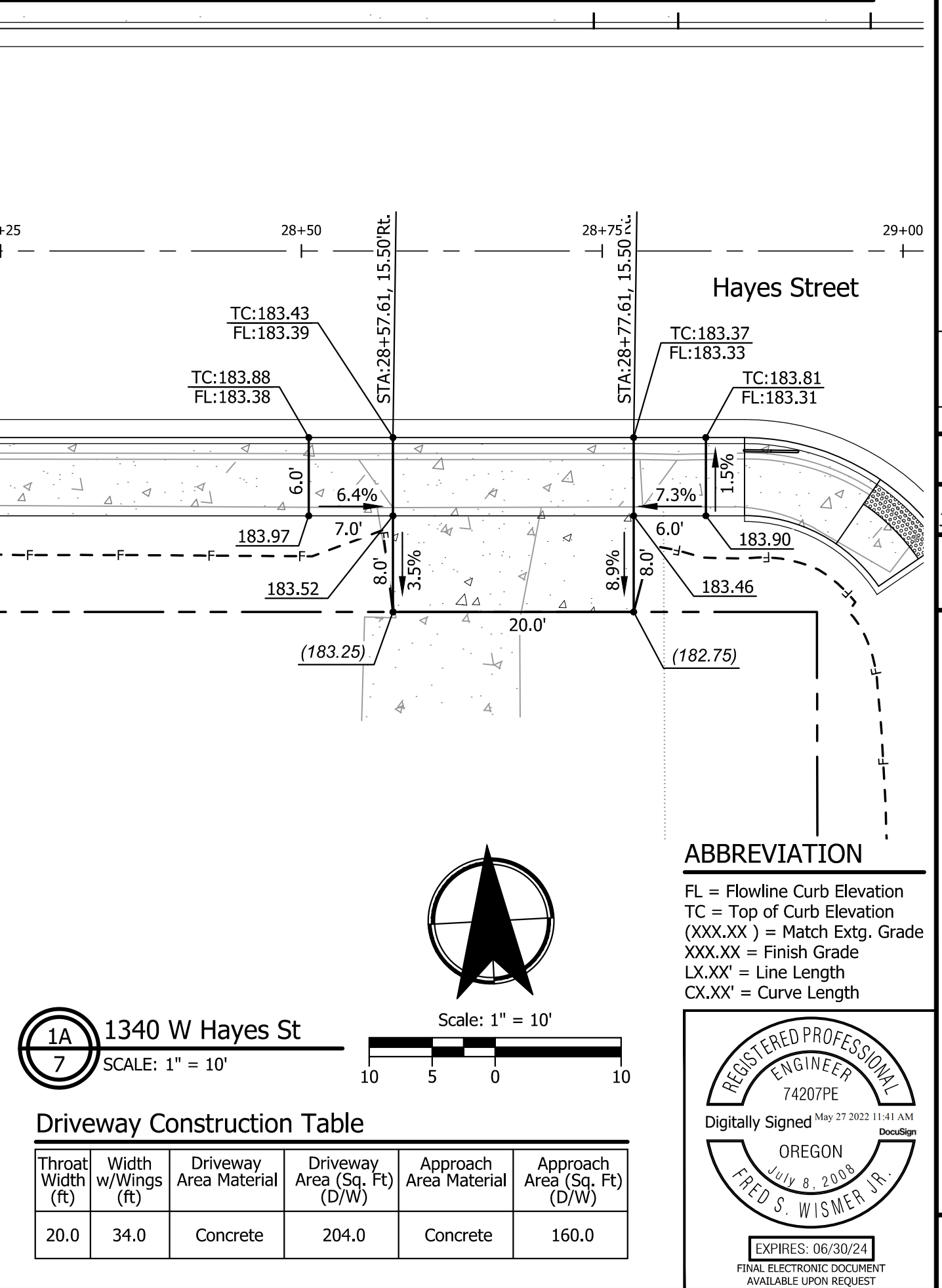

Driveway Construction Table

Throat Width (ft)	Width w/Wings (ft)	Driveway Area Material	Driveway Area (Sq. Ft) (D/W)	Approach Area Material	Approach Area (Sq. Ft) (D/W)
20.0	34.0	Concrete	204.0	Concrete	160.0

ABBREVIATION

FL = Flowline Curb Elevation
 TC = Top of Curb Elevation
 (XXX.XX) = Match Extg. Grade
 XXX.XX = Finish Grade
 LX.XX' = Line Length
 CX.XX' = Curve Length

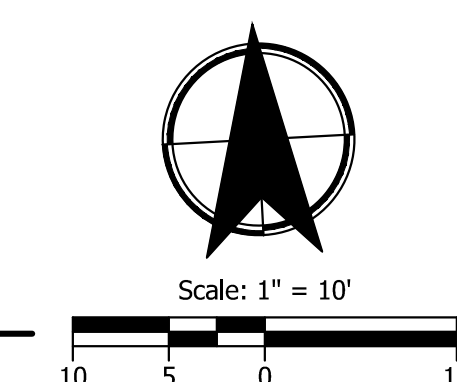

Scale: 1" = 10'

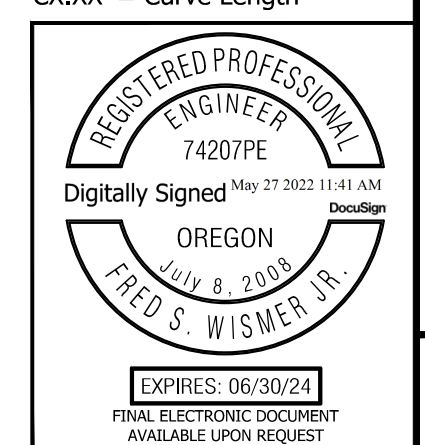

Plot Stamp: 5/27/2022 11:21:24 AM - Fred Wismer
 File: H:\24\24512 - W. Hayes Street\design\CD\CD-Detailed-Grading-Plans-DRWYS.dwg

NO.	DATE	REVISION	APP'D
0	05/25/22	ISSUE FOR CONSTRUCTION	FSW

Submission Date: 03/07/2022
 Drawn: JCB/RMM
 Designed: NRS/JBK
 Checked: FSW

PROJECT NO. 2015-001-20
W. Hayes Street Improvements
 Cascade Avenue to Settlemier Avenue
 DETAILED DRIVEWAY GRADING PLANS
 SHEET NO. 2E-12

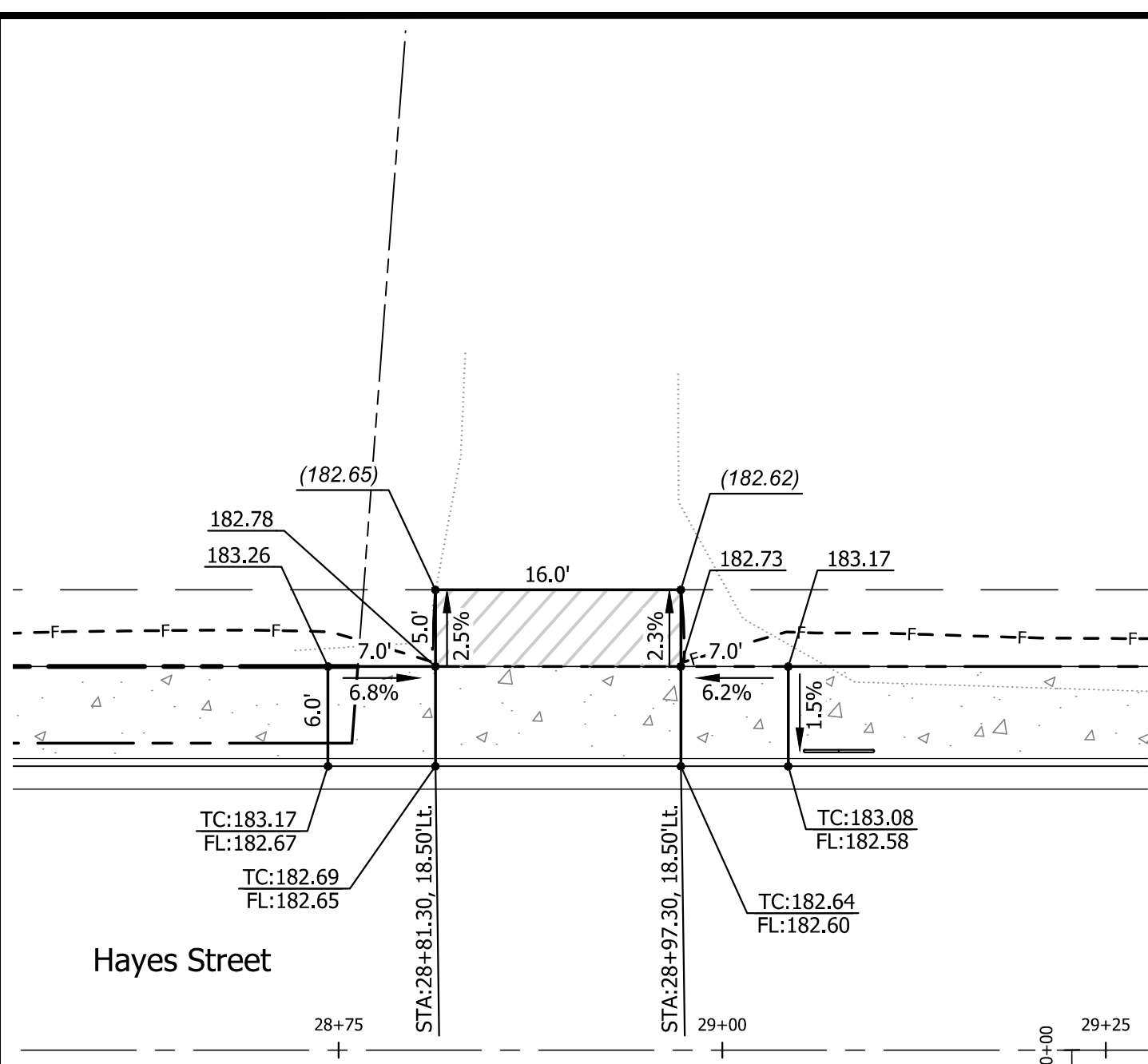

1B 1315-1311 W Hayes St
SCALE: 1" = 10'

Driveway Construction Table

Throat Width (ft)	Width w/Wings (ft)	Driveway Area Material	Driveway Area (Sq. Ft) (D/W)	Approach Area Material	Approach Area (Sq. Ft) (D/W)
26.0	32.0	Concrete	354.00	Asphalt	354.00

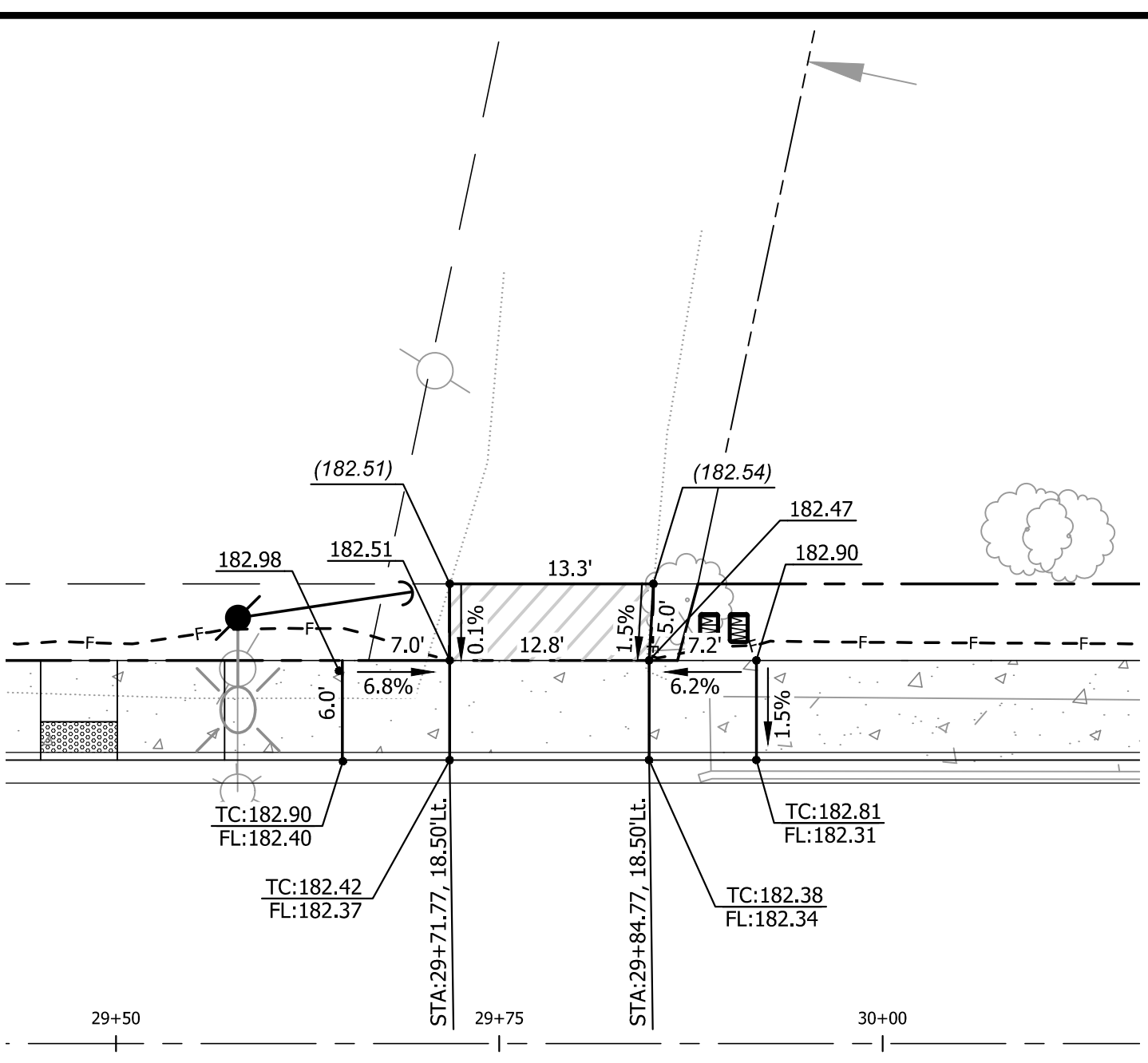

1C 1309 N Cascade Dr
SCALE: 1" = 10'

Driveway Construction Table

Throat Width (ft)	Width w/Wings (ft)	Driveway Area Material	Driveway Area (Sq. Ft) (D/W)	Approach Area Material	Approach Area (Sq. Ft) (D/W)
12.8	27.0	Concrete	162.0	Asphalt	65.7

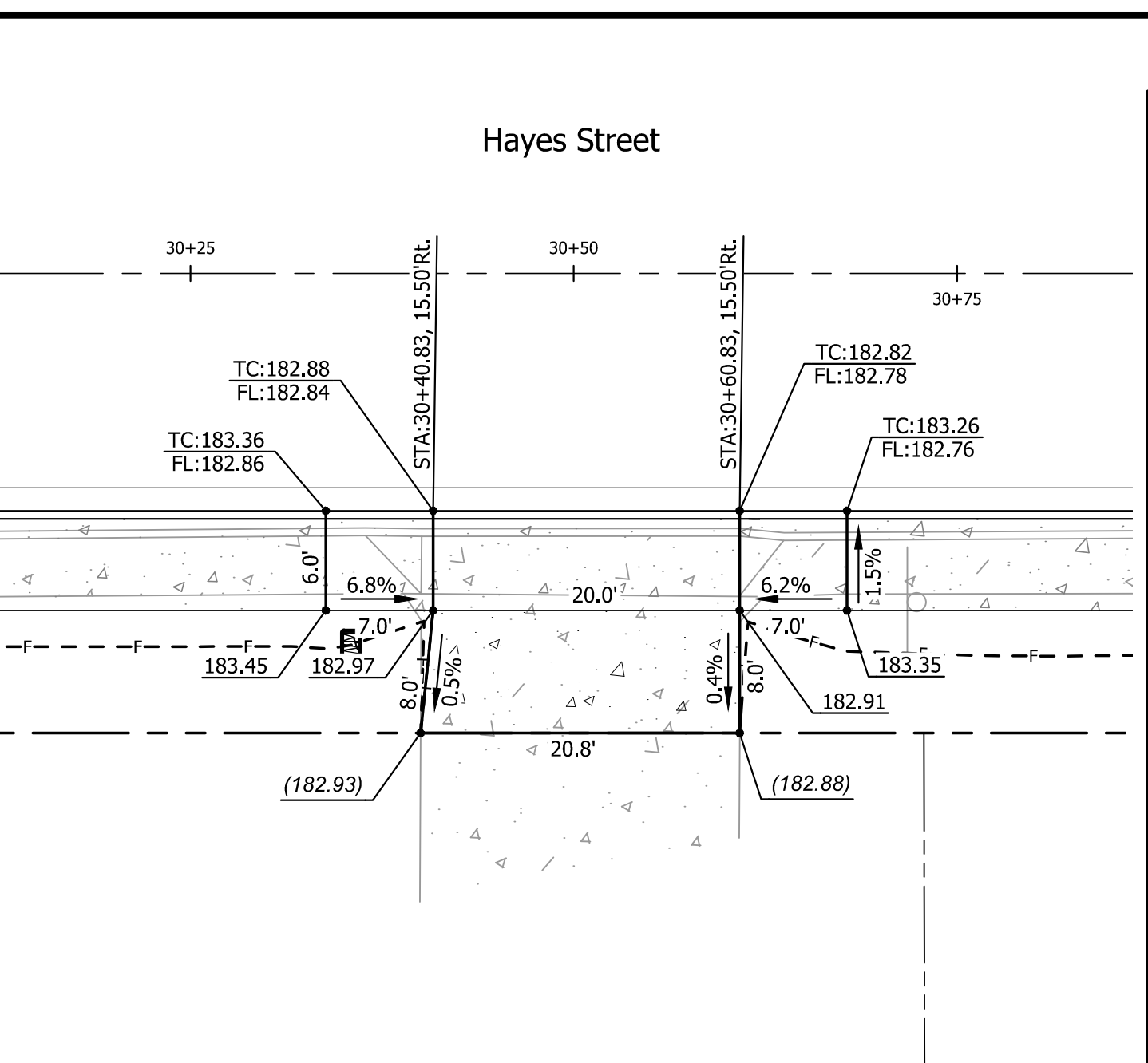

1D 1290 W Hayes St
SCALE: 1" = 10'

Driveway Construction Table

Throat Width (ft)	Width w/Wings (ft)	Driveway Area Material	Driveway Area (Sq. Ft) (D/W)	Approach Area Material	Approach Area (Sq. Ft) (D/W)
20.0	34.0	Concrete	204.0	Concrete	163.3

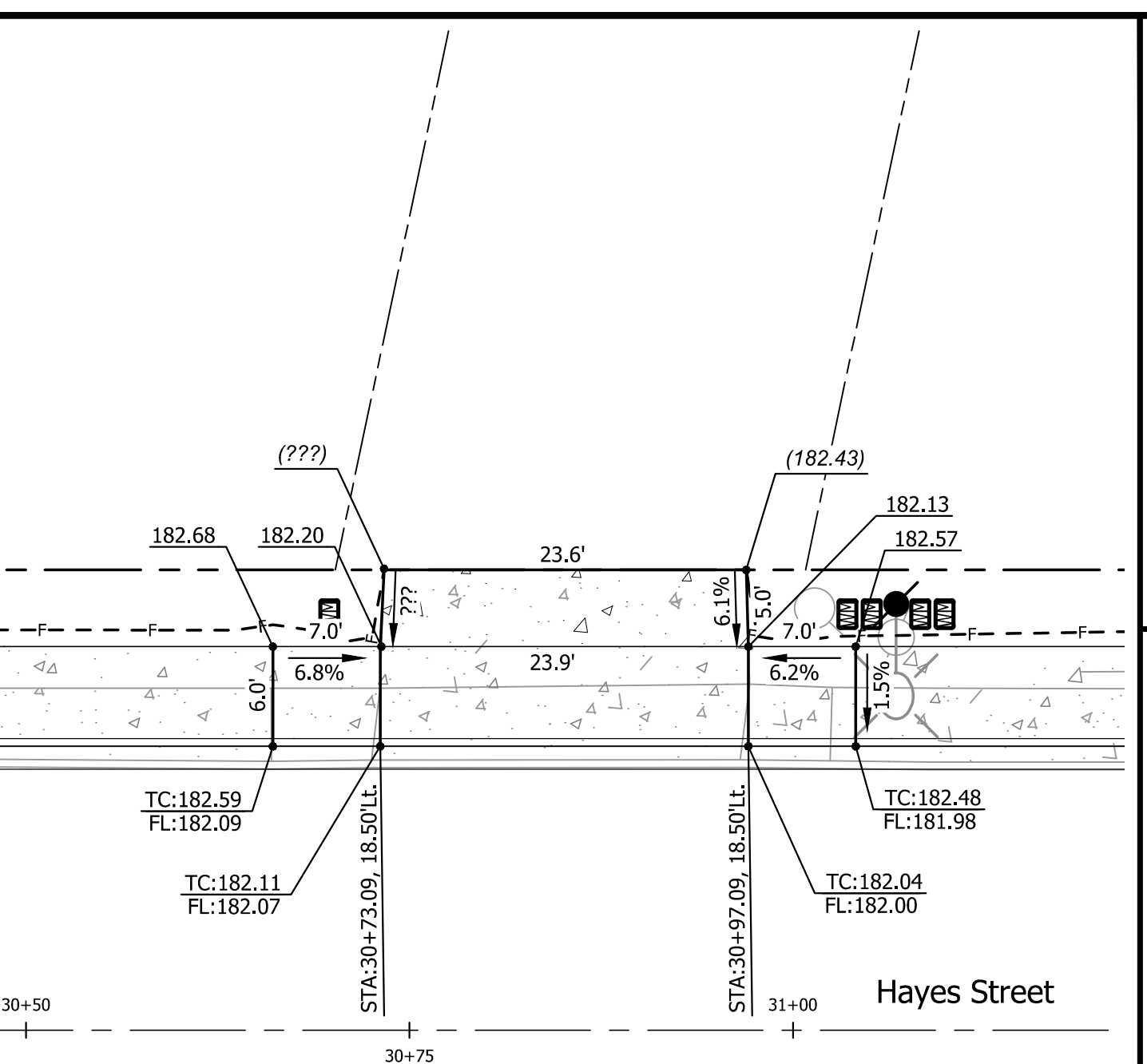

1E 1281-1277 W Hayes St
SCALE: 1" = 10'

Driveway Construction Table

Throat Width (ft)	Width w/Wings (ft)	Driveway Area Material	Driveway Area (Sq. Ft) (D/W)	Approach Area Material	Approach Area (Sq. Ft) (D/W)
23.9	37.9	Concrete	227.4	Concrete	119.1

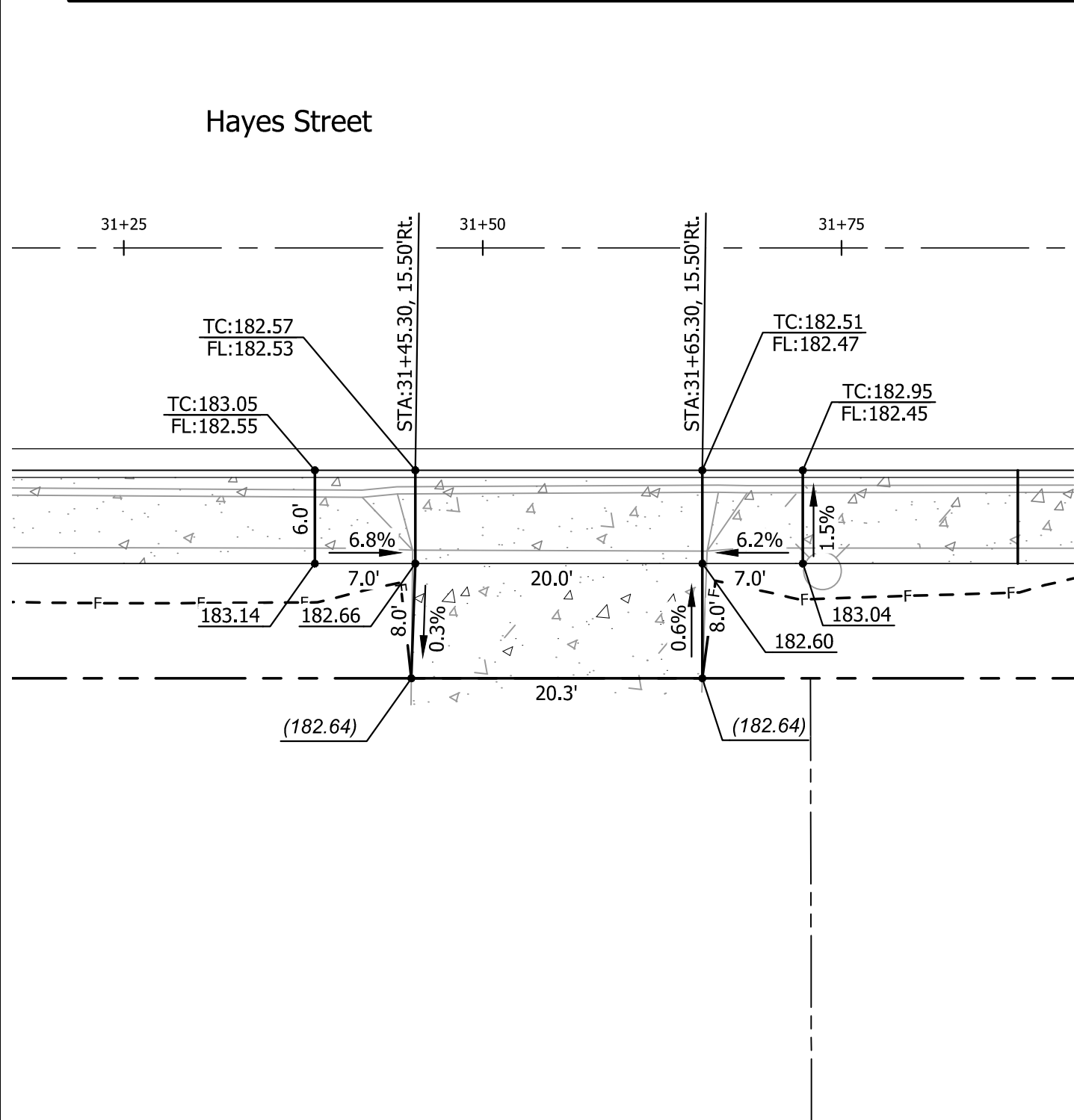

1F 1250 W Hayes St
SCALE: 1" = 10'

Driveway Construction Table

Throat Width (ft)	Width w/Wings (ft)	Driveway Area Material	Driveway Area (Sq. Ft) (D/W)	Approach Area Material	Approach Area (Sq. Ft) (D/W)
20.0	34.0	Concrete	204.0	Concrete	161.1

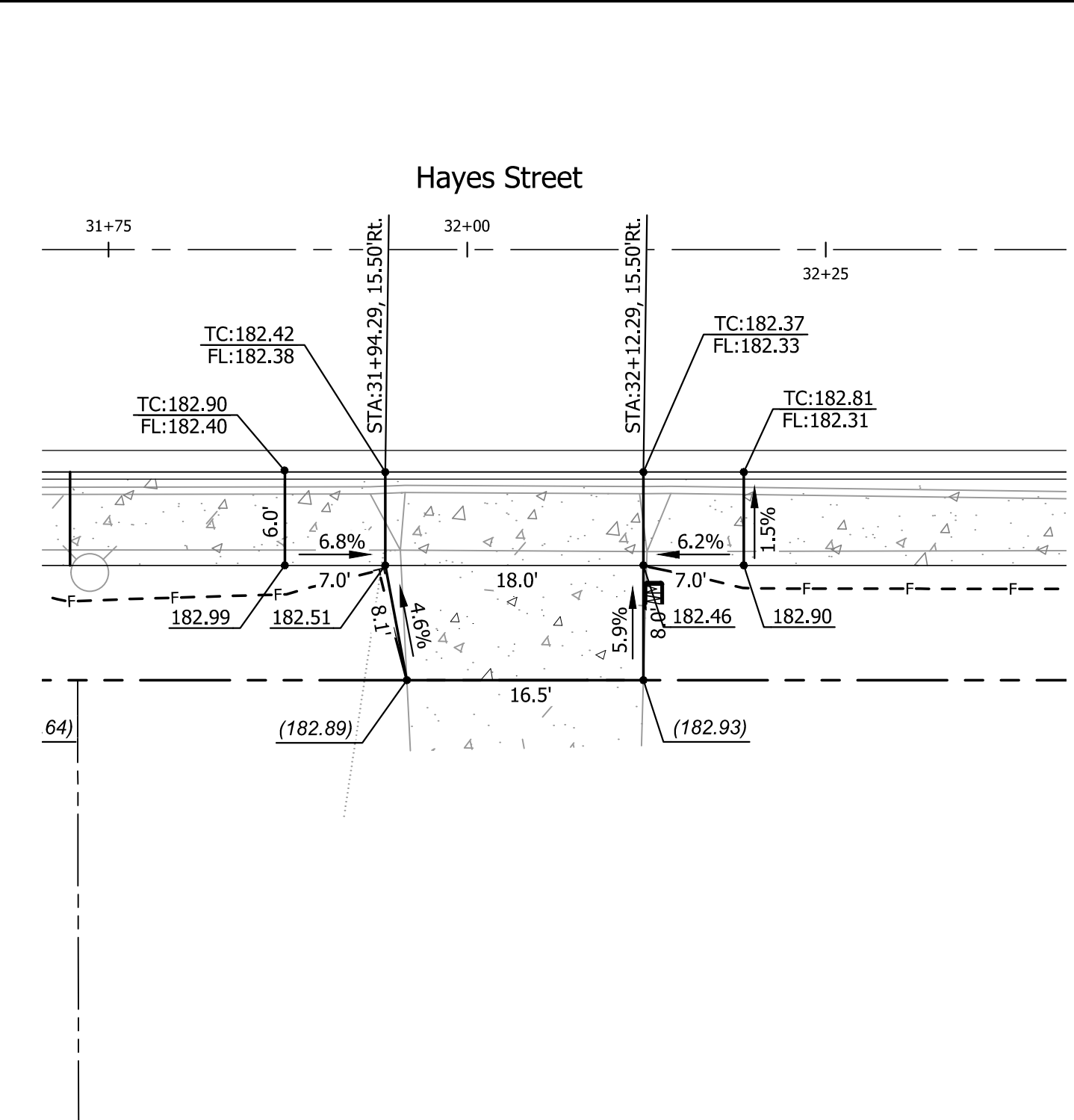

1G 1150 W Hayes St
SCALE: 1" = 10'

Driveway Construction Table

Throat Width (ft)	Width w/Wings (ft)	Driveway Area Material	Driveway Area (Sq. Ft) (D/W)	Approach Area Material	Approach Area (Sq. Ft) (D/W)
18.0	32.0	Concrete	192.0	Concrete	138.0

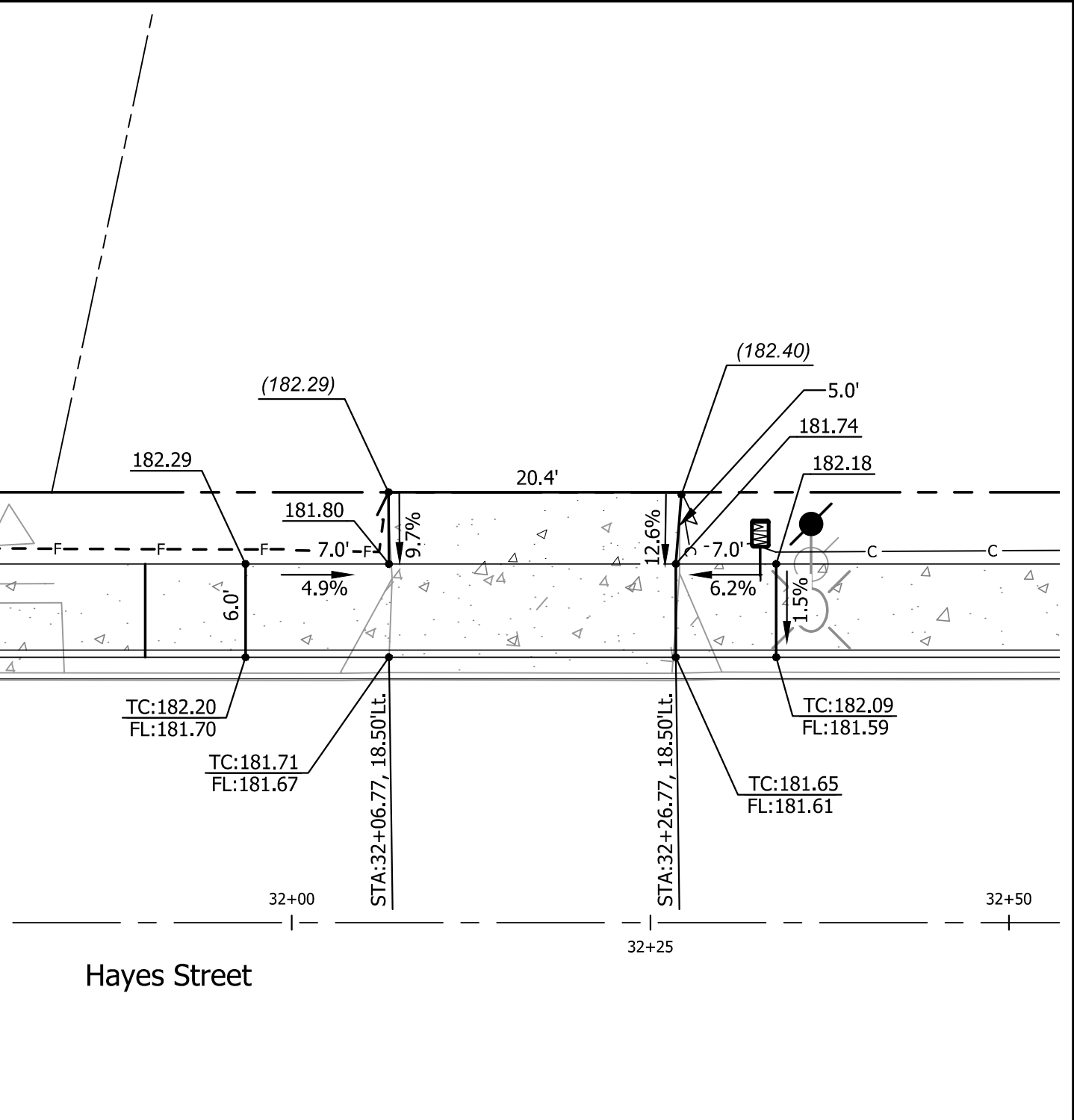

1H 1251 W Hayes St
SCALE: 1" = 10'

Driveway Construction Table

Throat Width (ft)	Width w/Wings (ft)	Driveway Area Material	Driveway Area (Sq. Ft) (D/W)	Approach Area Material	Approach Area (Sq. Ft) (D/W)
20.3	34.3	Concrete	204.0	Concrete	100.7

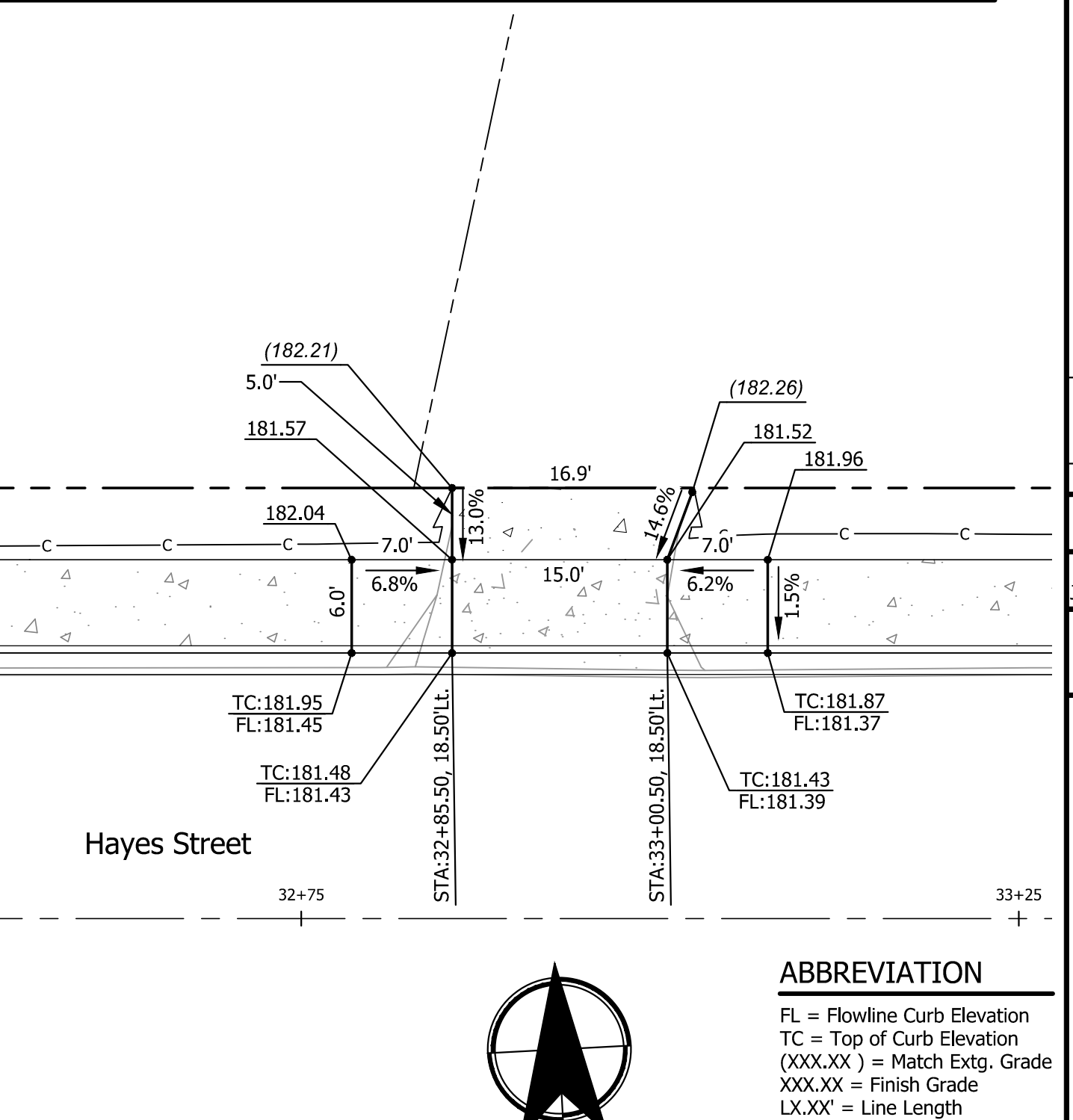

1A 507 Leasure St Garage
SCALE: 1" = 10'

Driveway Construction Table

Throat Width (ft)	Width w/Wings (ft)	Driveway Area Material	Driveway Area (Sq. Ft) (D/W)	Approach Area Material	Approach Area (Sq. Ft) (D/W)
15.0	29.0	Concrete	174.0	Concrete	80.1

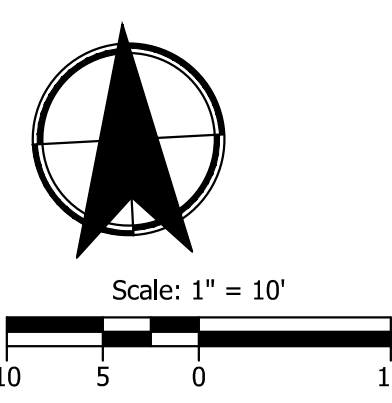

ABBREVIATION
 FL = Flowline Curb Elevation
 TC = Top of Curb Elevation
 (XXX.XX) = Match Extg. Grade
 XXX.XX = Finish Grade
 LX.XX' = Line Length
 CX.XX' = Curve Length

REGISTERED PROFESSIONAL ENGINEER
 74207PE
 Digitally Signed May 27 2022 11:41 AM
 OREGON
 JUL 8 2008
 FRED S. WISMER JR.
 EXPIRES: 06/30/24
 FINAL ELECTRONIC DOCUMENT
 AVAILABLE UPON REQUEST

NO.	DATE	REVISION	APP'D
0	05/25/22	ISSUE FOR CONSTRUCTION	FSW

Submission Date: 03/07/2022
 Drawn: JCB/RMM Designed: NRS/JBK Checked: FSW

PROJECT NO.
2015-001-20

W. Hayes Street Improvements
 Cascade Avenue to Settlemier Avenue

DETAILED DRIVEWAY GRADING PLANS

SHEET NO.
2F-13

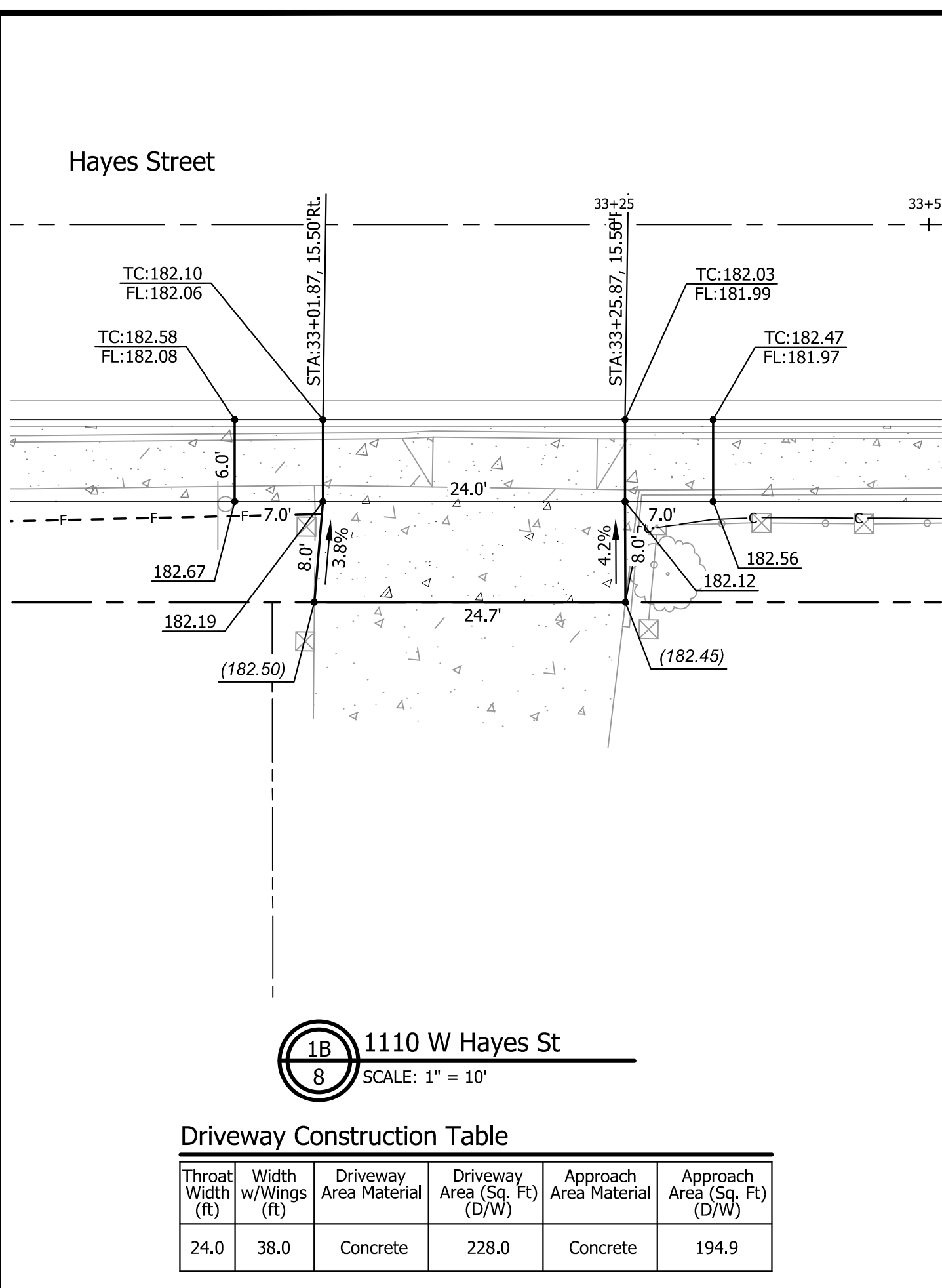

Driveway Construction Table

Throat Width (ft)	Width w/Wings (ft)	Driveway Area Material	Driveway Area (Sq. Ft) (D/W)	Approach Area Material	Approach Area (Sq. Ft) (D/W)
24.0	38.0	Concrete	228.0	Concrete	194.9

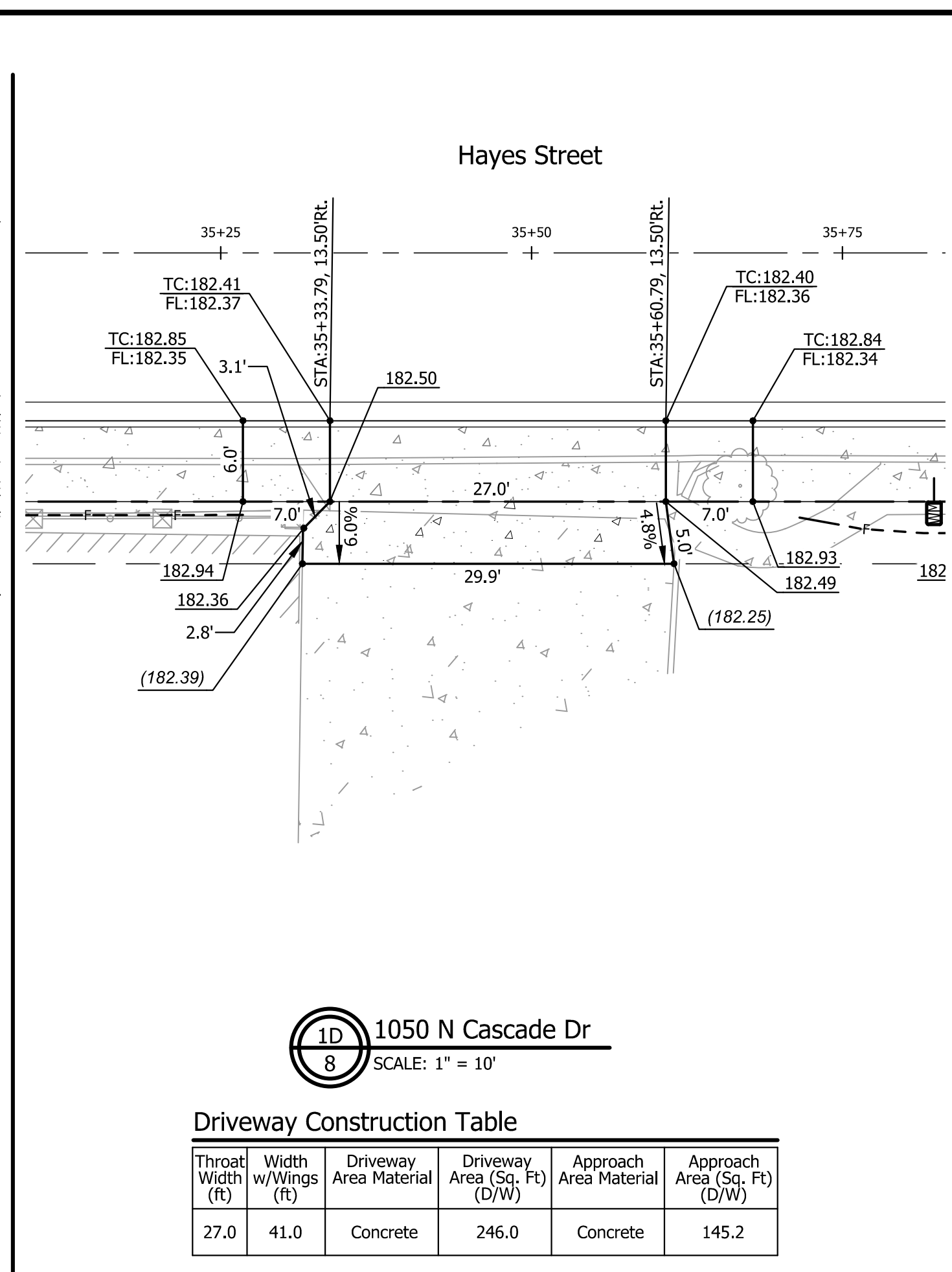

Driveway Construction Table

Throat Width (ft)	Width w/Wings (ft)	Driveway Area Material	Driveway Area (Sq. Ft) (D/W)	Approach Area Material	Approach Area (Sq. Ft) (D/W)
27.0	41.0	Concrete	246.0	Concrete	145.2

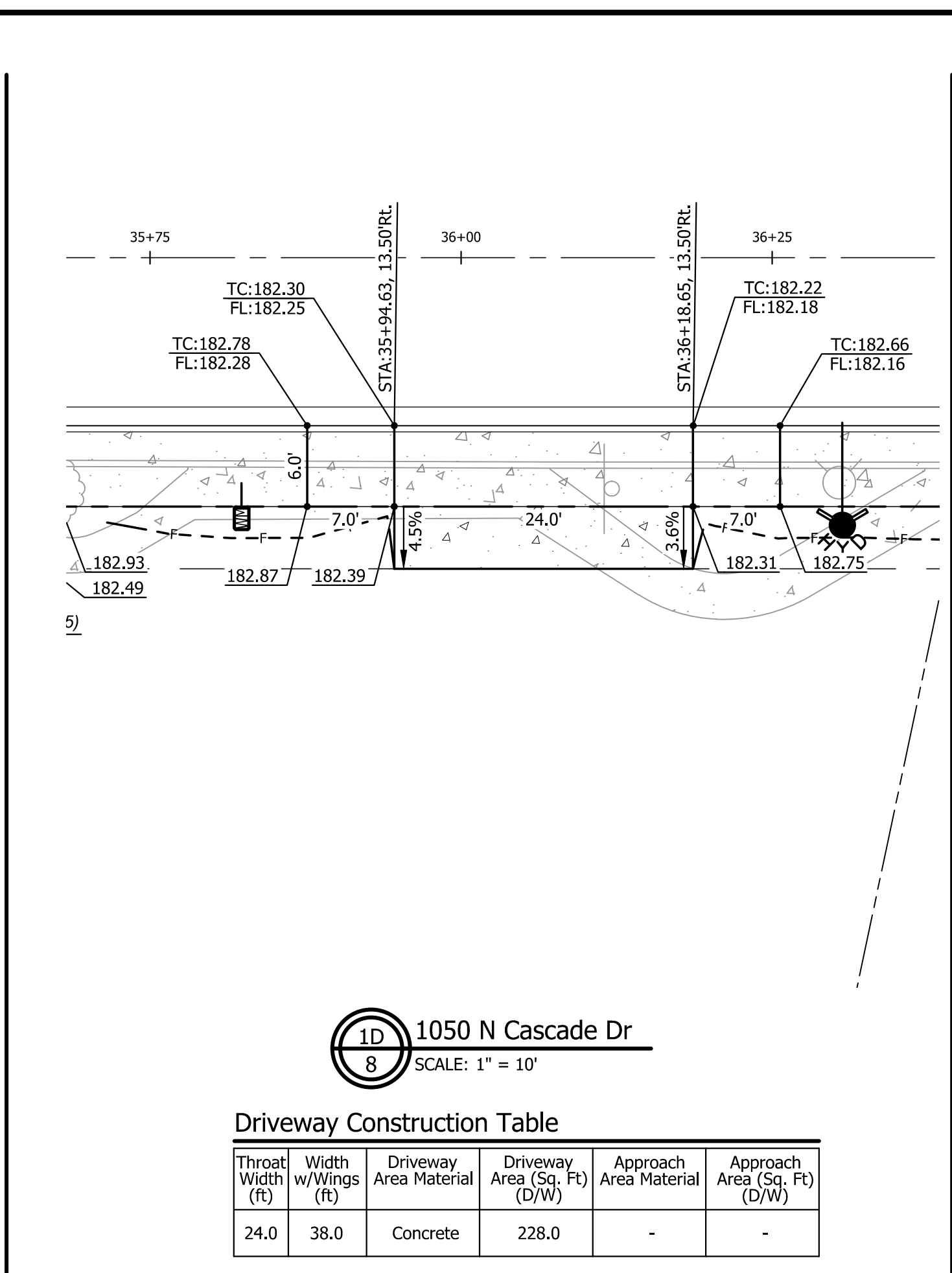

Driveway Construction Table

Throat Width (ft)	Width w/Wings (ft)	Driveway Area Material	Driveway Area (Sq. Ft) (D/W)	Approach Area Material	Approach Area (Sq. Ft) (D/W)
24.0	38.0	Concrete	228.0	-	-

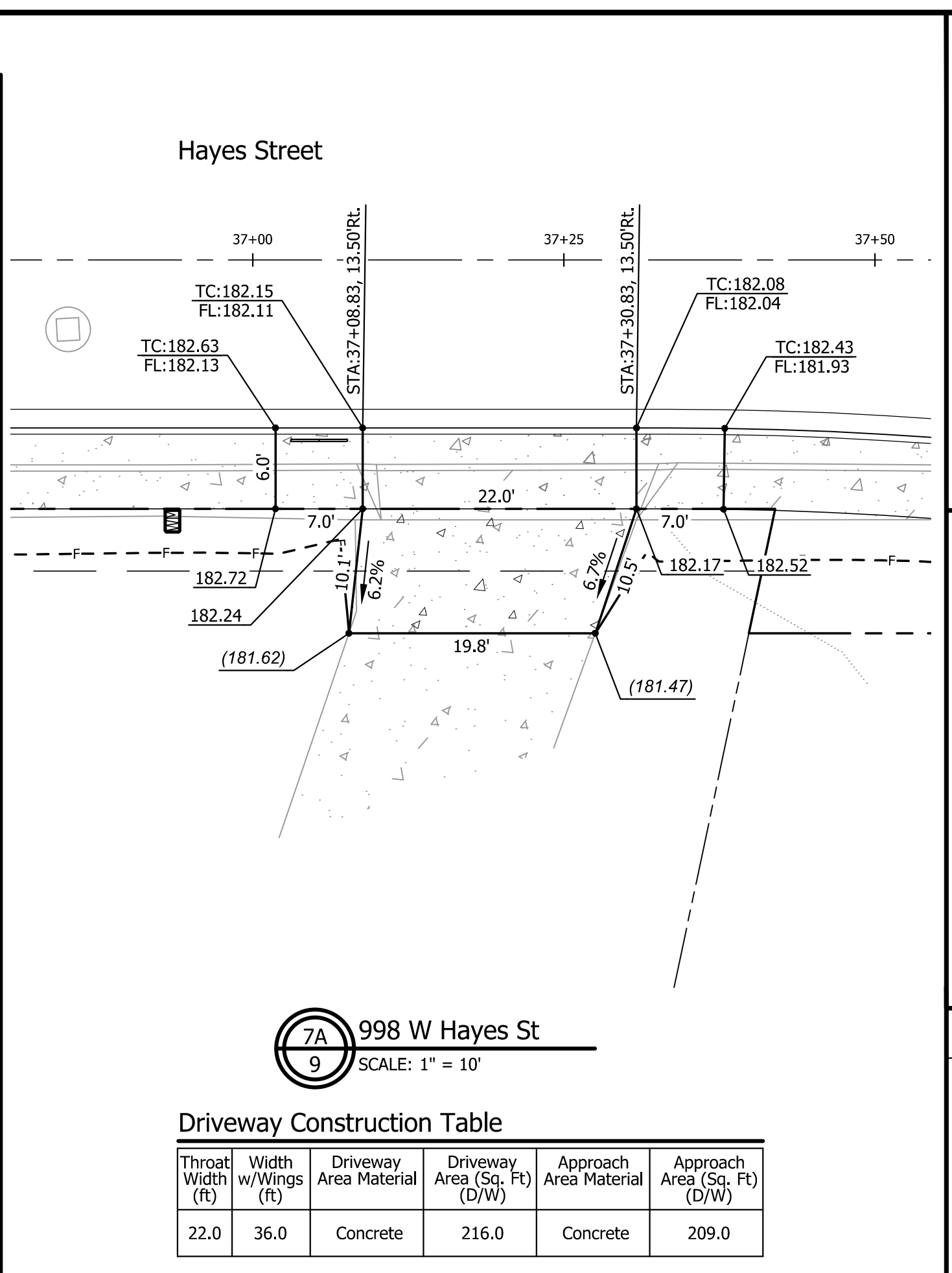

Driveway Construction Table

Throat Width (ft)	Width w/Wings (ft)	Driveway Area Material	Driveway Area (Sq. Ft) (D/W)	Approach Area Material	Approach Area (Sq. Ft) (D/W)
22.0	36.0	Concrete	216.0	Concrete	209.0

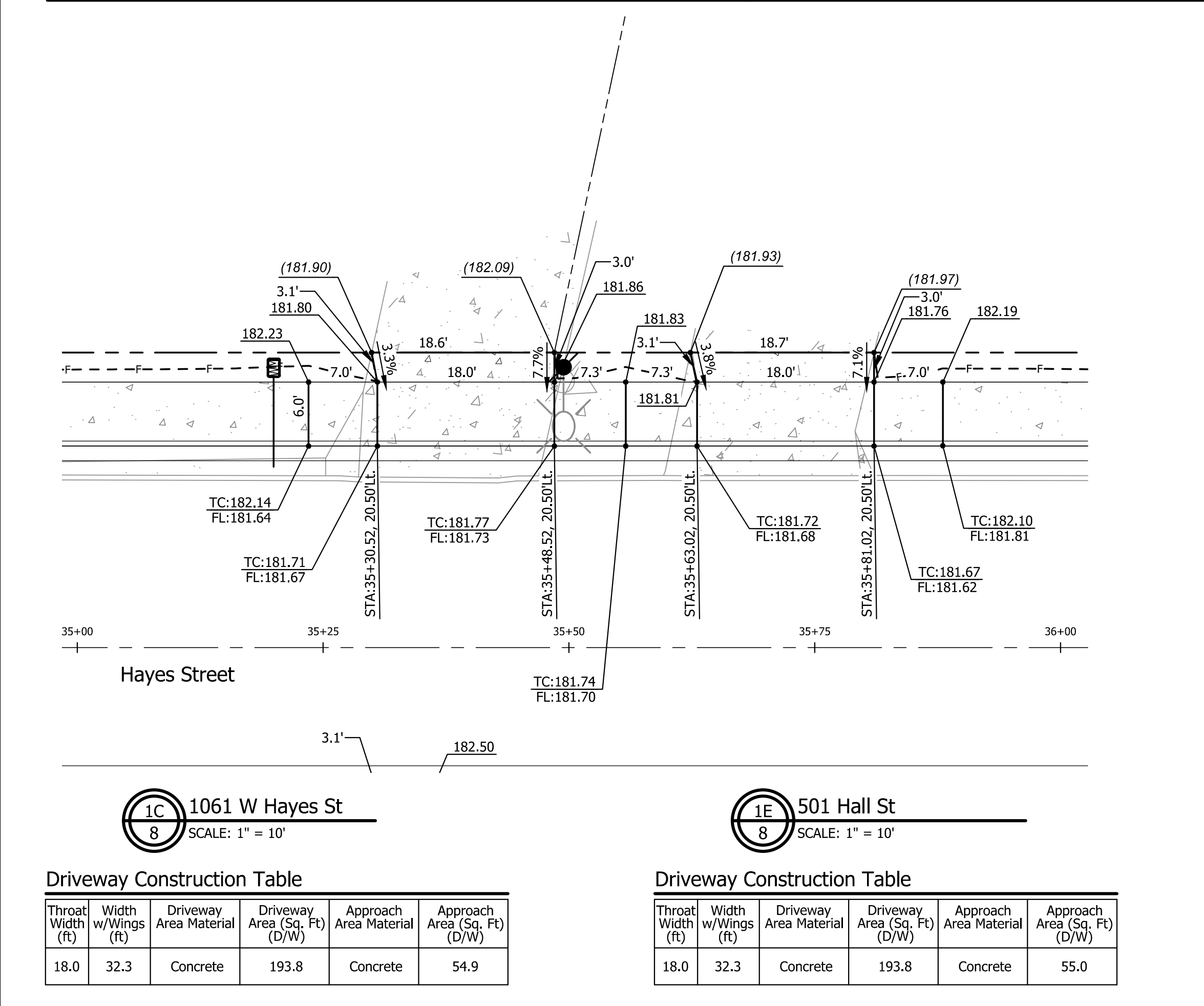

Driveway Construction Table

Throat Width (ft)	Width w/Wings (ft)	Driveway Area Material	Driveway Area (Sq. Ft) (D/W)	Approach Area Material	Approach Area (Sq. Ft) (D/W)
18.0	32.3	Concrete	193.8	Concrete	54.9

Driveway Construction Table

Throat Width (ft)	Width w/Wings (ft)	Driveway Area Material	Driveway Area (Sq. Ft) (D/W)	Approach Area Material	Approach Area (Sq. Ft) (D/W)
18.0	32.3	Concrete	193.8	Concrete	55.0

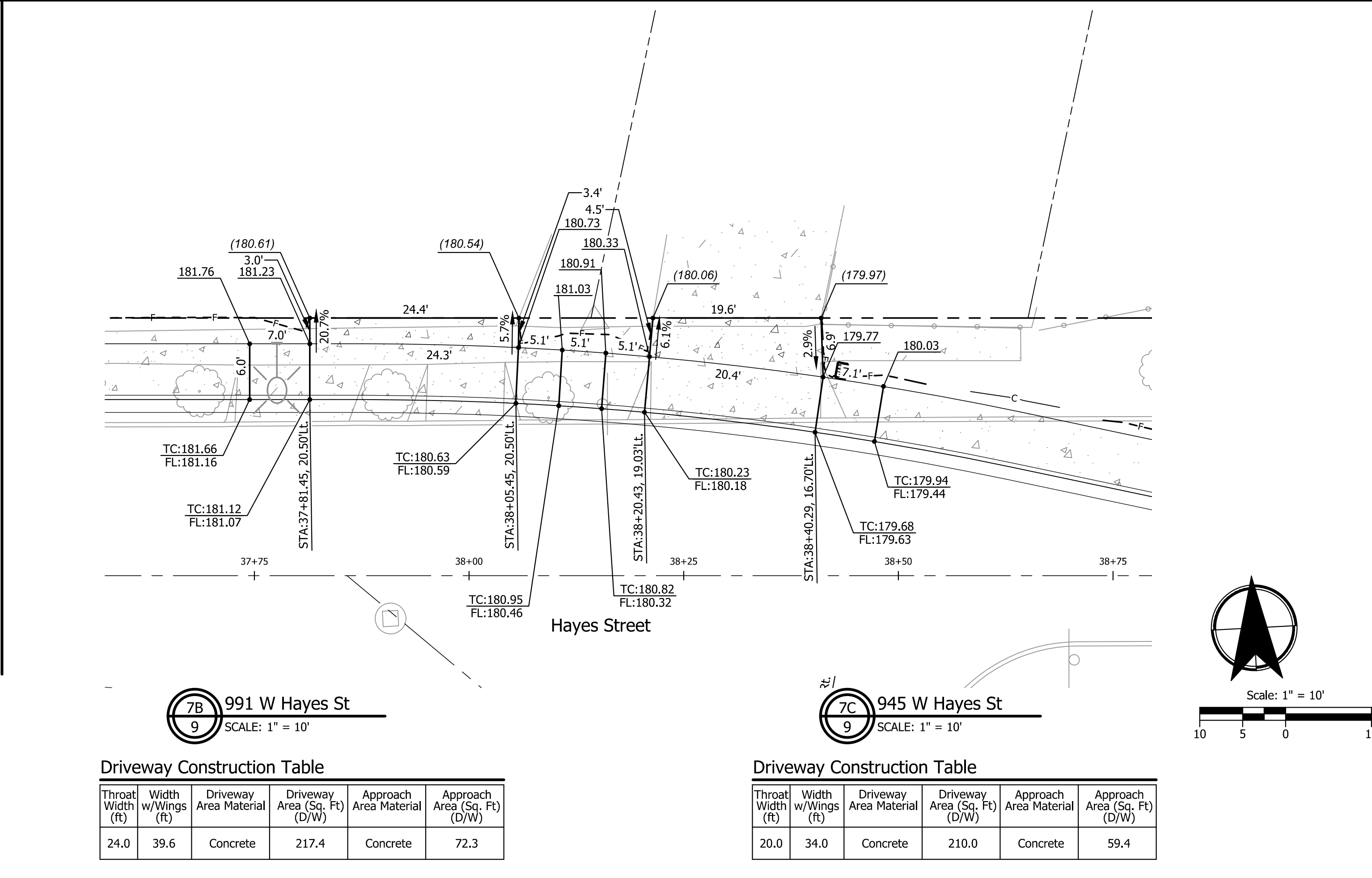

Driveway Construction Table

Throat Width (ft)	Width w/Wings (ft)	Driveway Area Material	Driveway Area (Sq. Ft) (D/W)	Approach Area Material	Approach Area (Sq. Ft) (D/W)
24.0	39.6	Concrete	217.4	Concrete	72.3

Driveway Construction Table

Throat Width (ft)	Width w/Wings (ft)	Driveway Area Material	Driveway Area (Sq. Ft) (D/W)	Approach Area Material	Approach Area (Sq. Ft) (D/W)
20.0	34.0	Concrete	210.0	Concrete	59.4

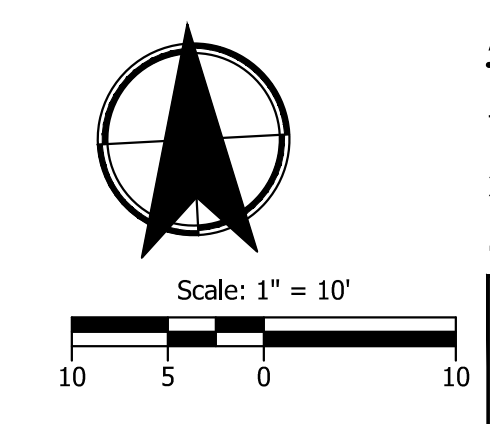

ABBREVIATION

FL = Flowline Curb Elevation
 TC = Top of Curb Elevation
 (XXX.XX) = Match Extg. Grade
 XXX.XX = Finish Grade
 LX.XX' = Line Length
 CX.XX' = Curve Length

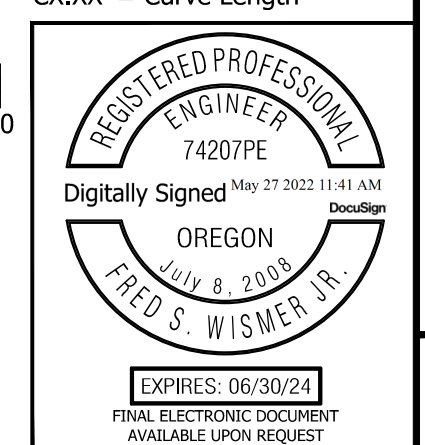

Plot Stamp: 5/27/2022 11:22:31 AM - Fred Wismer
 File: H:\24\24512 - W. Hayes Street\design\CD\CD-Detailed-Grading-Plans-DRWYS.dwg

NO.	REVISION	DATE	BY	APP'D
0	ISSUE FOR CONSTRUCTION	05/25/22	FSW	

Submission Date: 03/07/2022
 Drawn: JCB/RMM
 Designed: NRS/JBK
 Checked: FSW

PROJECT NO.
2015-001-20

W. Hayes Street Improvements
 Cascade Avenue to Settlemier Avenue

DETAILED DRIVEWAY GRADING PLANS

SHEET NO.
2E-14

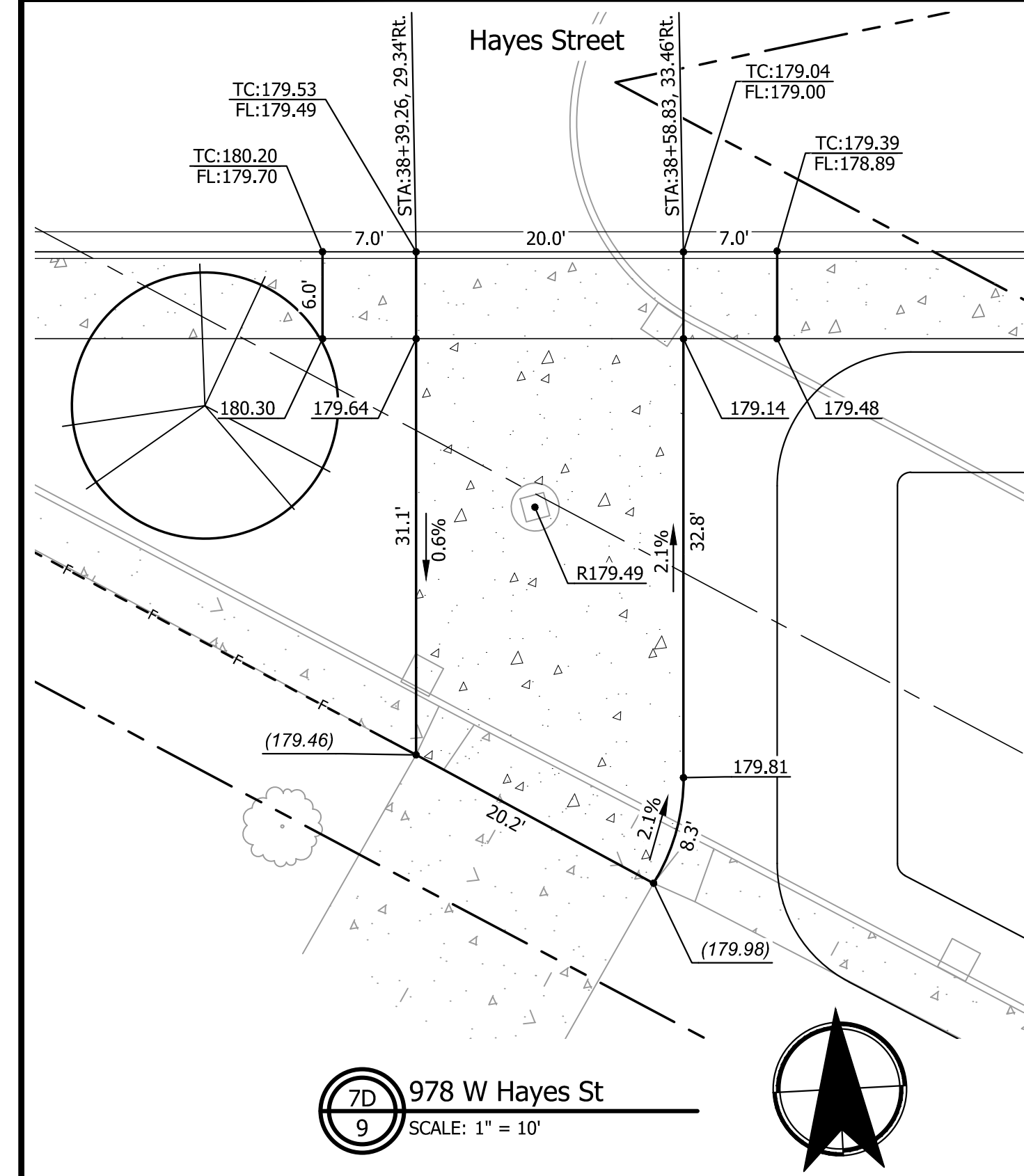

7D
9 978 W Hayes St
SCALE: 1" = 10'

Driveway Construction Table

Throat Width (ft)	Width w/Wings (ft)	Driveway Area Material	Driveway Area (Sq. Ft) (D/W)	Approach Area Material	Approach Area (Sq. Ft) (D/W)
20.0	34.0	Concrete	204.0	Concrete	723.8

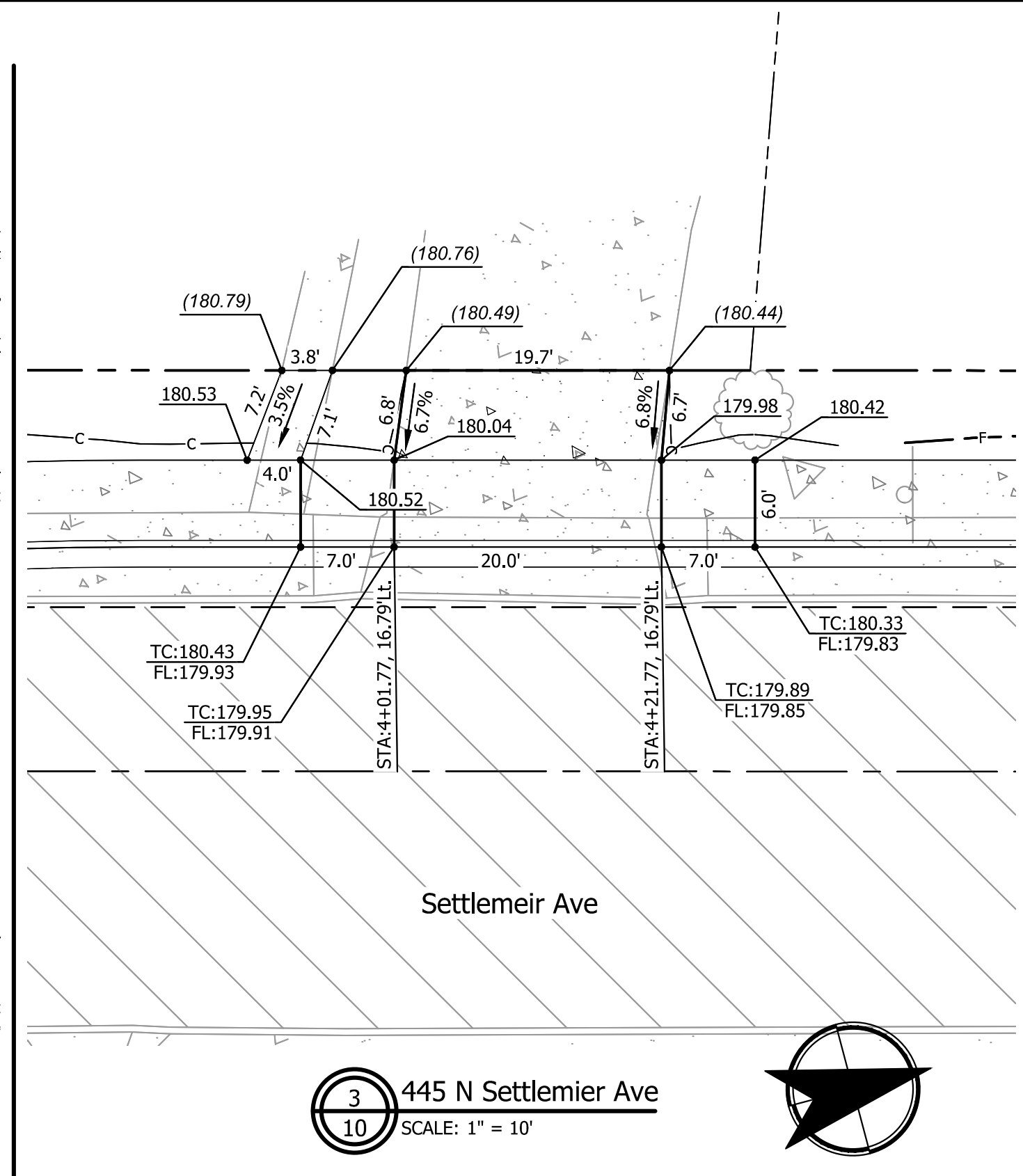

3
10 445 N Settlemier Ave
SCALE: 1" = 10'

Driveway Construction Table

Throat Width (ft)	Width w/Wings (ft)	Driveway Area Material	Driveway Area (Sq. Ft) (D/W)	Approach Area Material	Approach Area (Sq. Ft) (D/W)
20.0	34.0	Concrete	204.0	Concrete	134.0

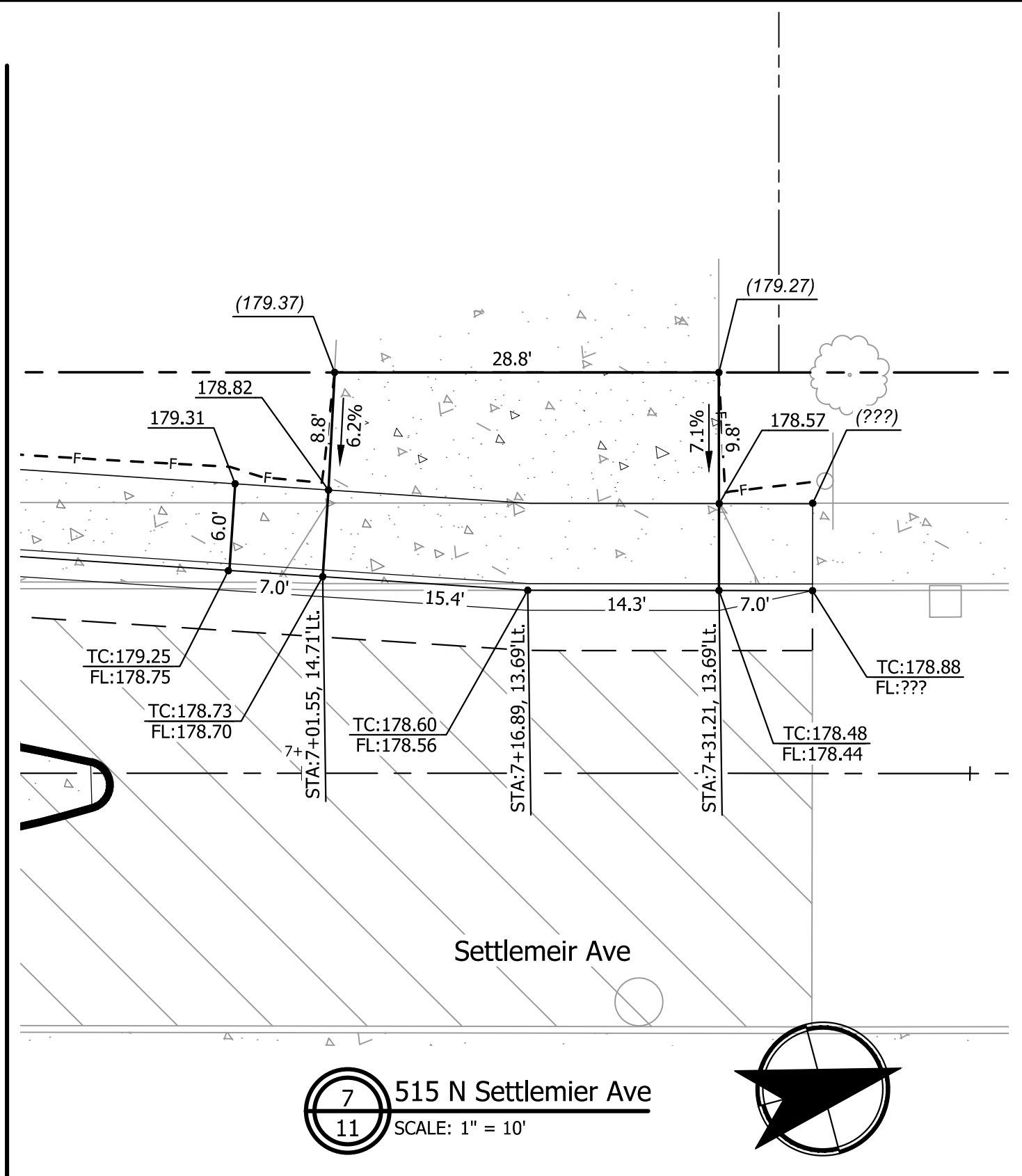

7
11 515 N Settlemier Ave
SCALE: 1" = 10'

Driveway Construction Table

Throat Width (ft)	Width w/Wings (ft)	Driveway Area Material	Driveway Area (Sq. Ft) (D/W)	Approach Area Material	Approach Area (Sq. Ft) (D/W)
29.7	43.7	Concrete	262.2	Concrete	282.3

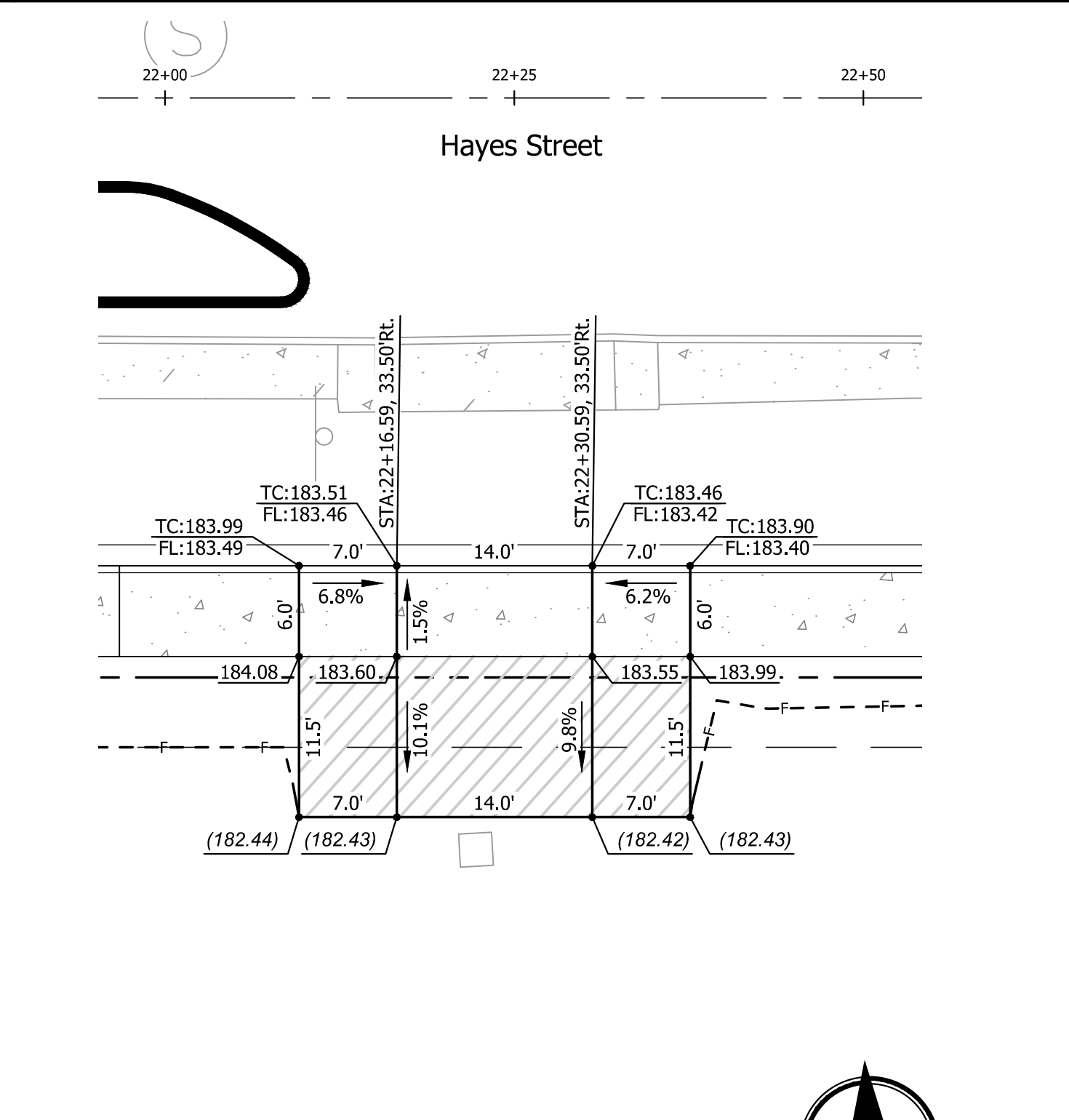

1E
5 1621 W Hayes St - West
SCALE: 1" = 10'

Driveway Construction Table

Throat Width (ft)	Width w/Wings (ft)	Driveway Area Material	Driveway Area (Sq. Ft) (D/W)	Approach Area Material	Approach Area (Sq. Ft) (D/W)
14.0	28.0	Concrete	168.0	Asphalt	322.0

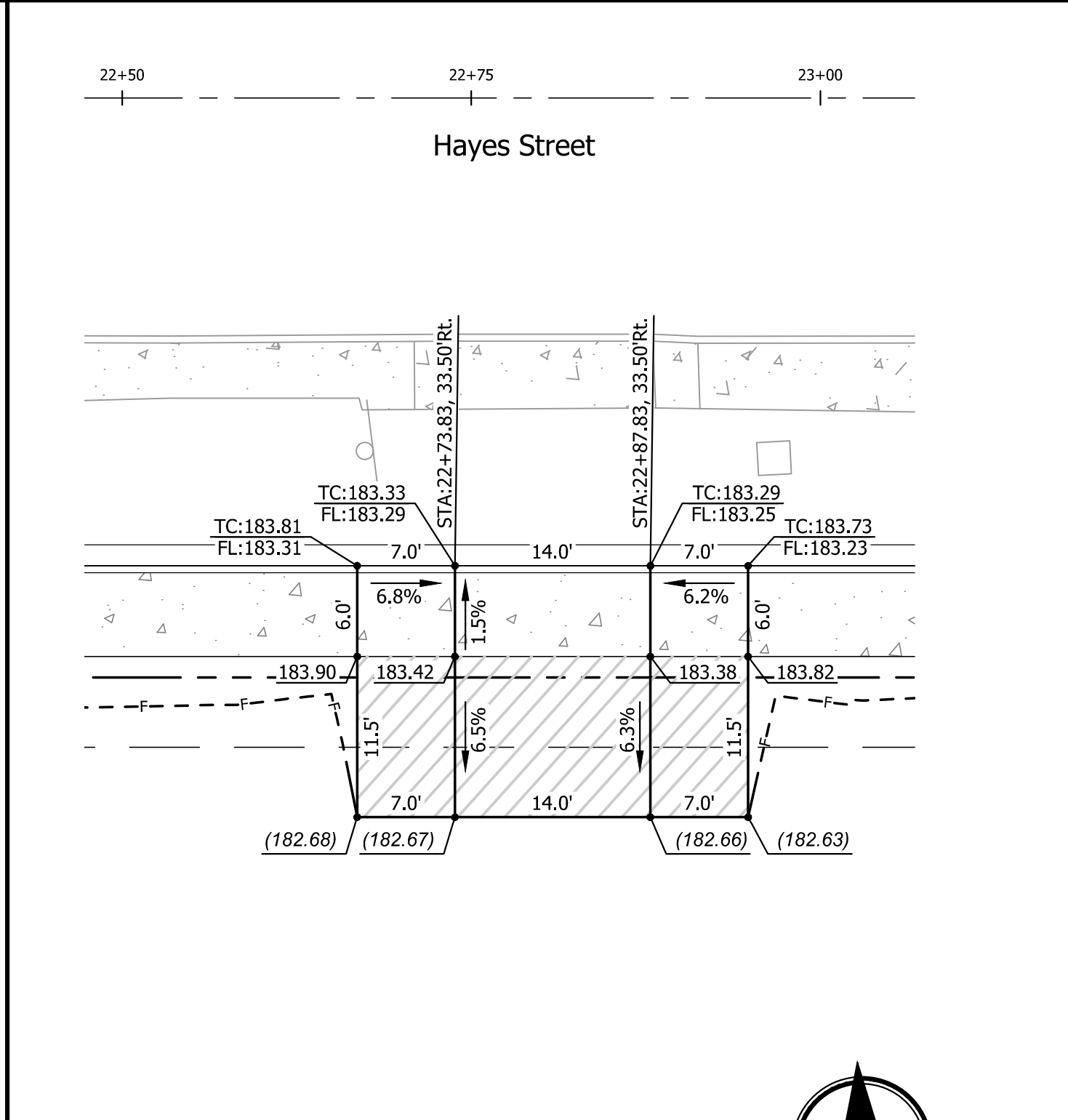

1F
5 1621 W Hayes St - East
SCALE: 1" = 10'

Driveway Construction Table

Throat Width (ft)	Width w/Wings (ft)	Driveway Area Material	Driveway Area (Sq. Ft) (D/W)	Approach Area Material	Approach Area (Sq. Ft) (D/W)
14.0	28.0	Concrete	168.0	Asphalt	322.0

ABBREVIATION

- FL = Flowline Curb Elevation
- TC = Top of Curb Elevation
- (XXX.XX) = Match Extg. Grade
- XXX.XX = Finish Grade
- LX.XX' = Line Length
- CX.XX' = Curve Length

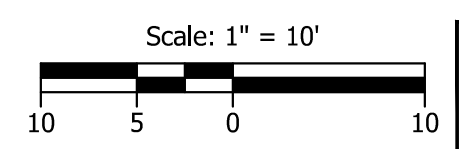

EXPIRES: 06/30/24
 FINAL ELECTRONIC DOCUMENT
 AVAILABLE UPON REQUEST

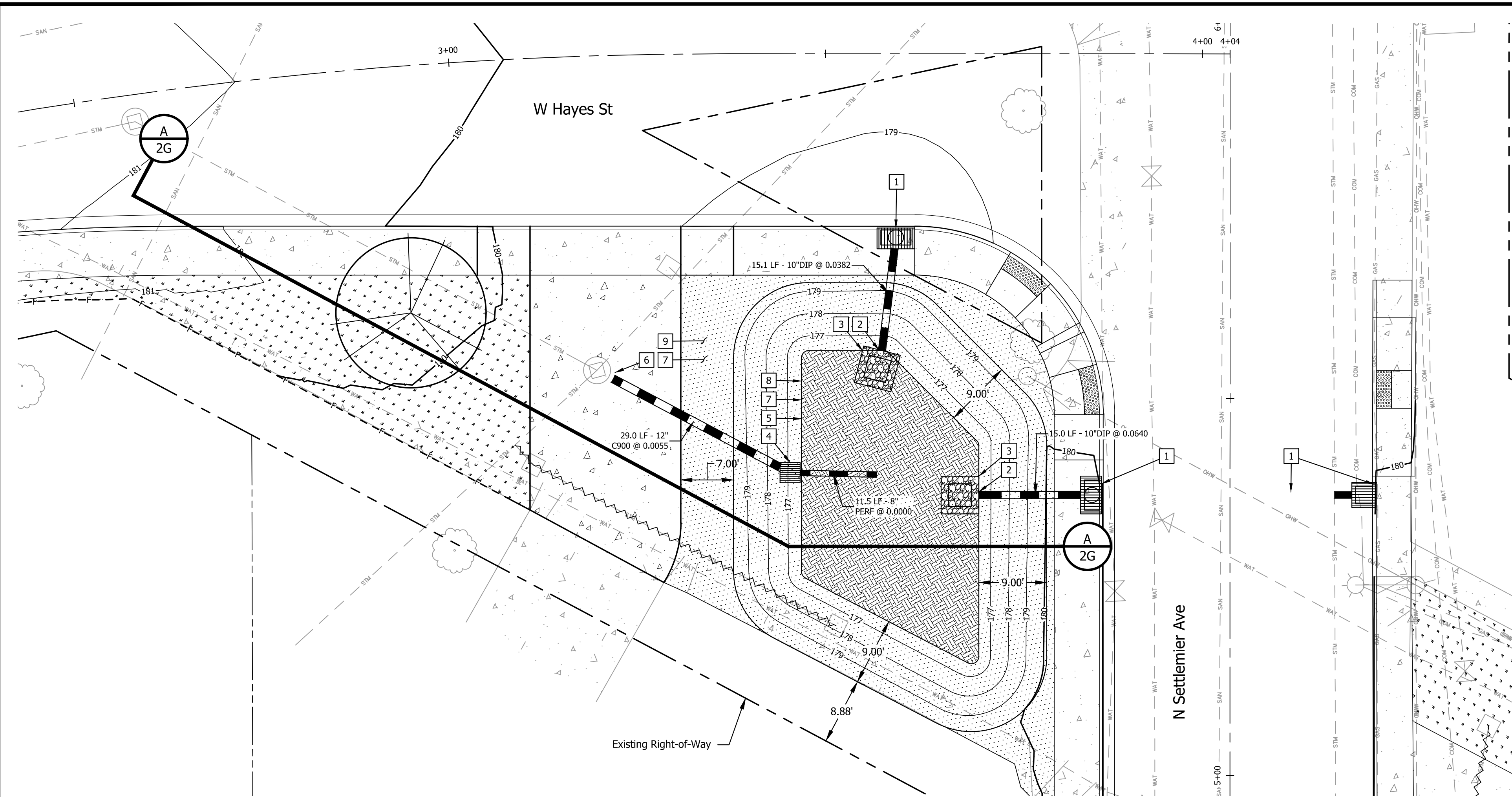

Access Grid filled with Water Quality Mix.
Access Grid to be NDS EZ Roll Grass Pavers
or Approved Equal from ODOT QPL.
Permanent Water Quality Seeding

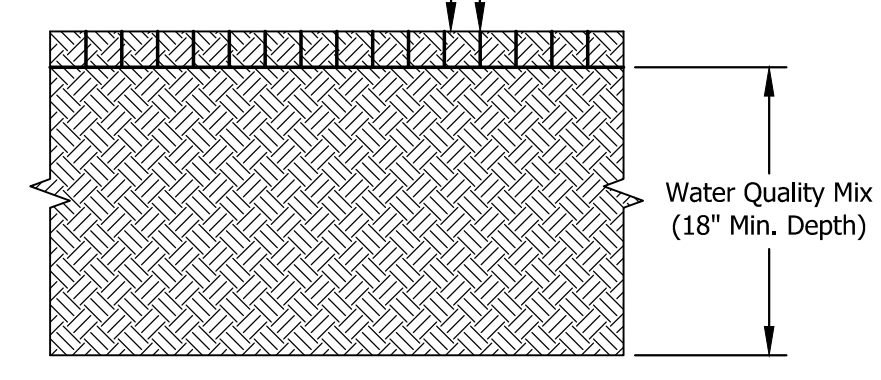

Water Quality Soil Media Properties	
Sieve Size	Percent Passing (By Weight)
No. 4	100
No. 10	95 - 100
No. 40	40 - 60
No. 100	10 - 25
No. 200	5 - 10

General Notes

- Water Quality Mix shall be 20% - 25% medium type compost with 75% - 80% water quality soil media.
- Soil sampling must meet the requirements of AASHTO T2.
- Sieve analysis must meet the requirements of AASHTO T27 and AASHTO T11.
- Soil pH range should be between 5.5 to 8.0.
- Medium type compost shall meet the requirements of Section 03020 of the 2021 Oregon Standard Specifications for Construction.
- Contractor shall use a manually operated landscape water filled roller to compact the water quality mix.
- Contractor shall rake level and remove surface rocks larger than 1-inch diameter.

Biofiltration Media Detail

SCALE: NTS

STORM CONSTRUCTION NOTES

- Proposed Storm System
See Sheets 3 thru 11 for Details and Elevation Information
- Proposed Storm Outfall with Sloped Pipe End (2 Ea.)
W. Hayes Street STA 38+81.55, 55.10' Rt. IE = 176.34
N Settlemier STA 5+37.17, 33.32' Lt. IE = 176.34
- Construct Class 50 Riprap Energy Dissipater (5' W x 5' L x 12" D) (2 Ea.)
- Construct Ditch Inlet per CWS Standard Drawing No. 390
See Sheet 2B-5 for details
- Install Access Grid and 18" of Bio-filtration Media Along Pond Bottom (±725 SF). See Detail This Sheet
- Connect to Existing Manhole (1 Ea.)
- Install Permanent Water Quality Seeding (±2,655 SF)
For Seeding Information, See Below.
- Pond Bottom Elevation = 176.34'
- Install 4" of Topsoil

LEGEND

- Permanent Lawn Seeding Area
See Sheets 3 Thru 12 for More Information
- Bio-filtration Media Area Per Detail This Sheet (±725 SF)
- Permanent Water Quality Seeding Area (±2,655 SF)
- Proposed Riprap Area per Construction Notes This Sheet

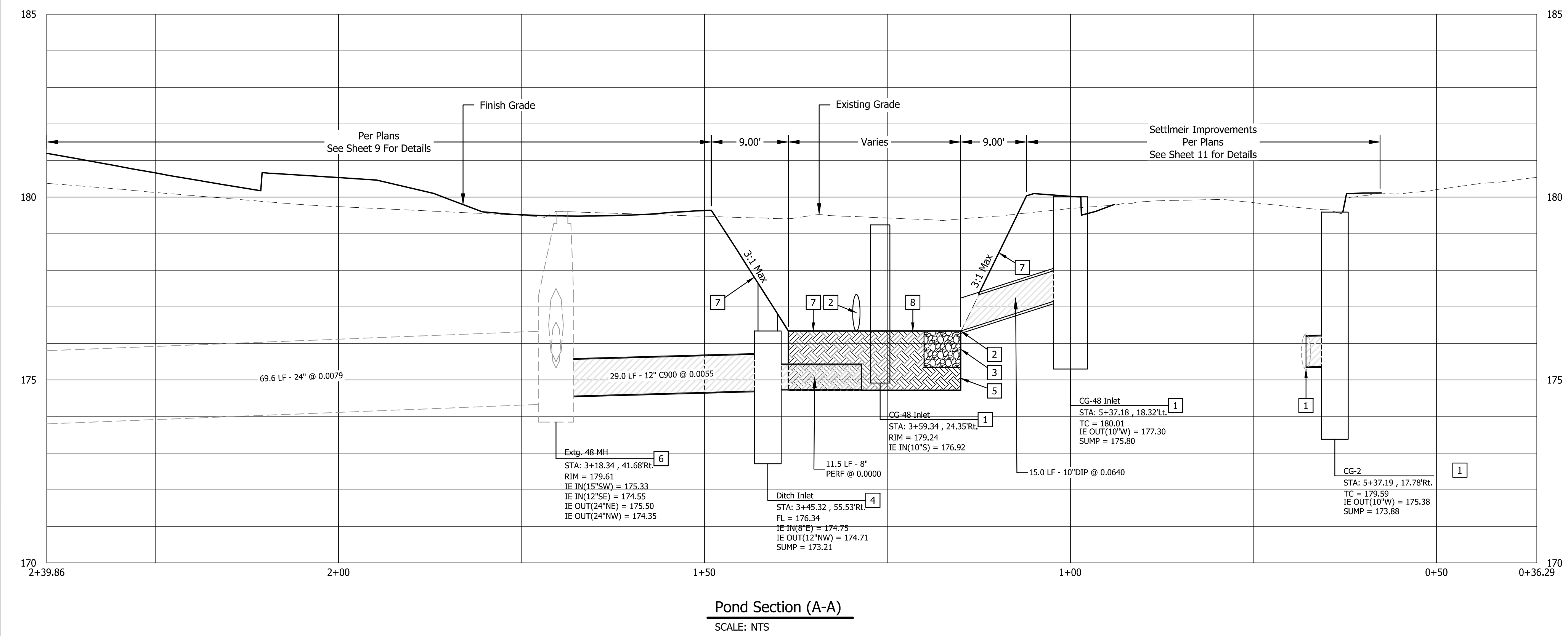

Pond Section (A-A)

SCALE: NTS

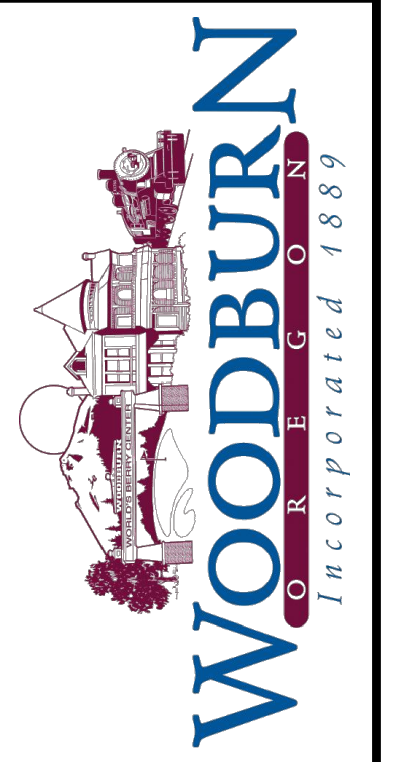
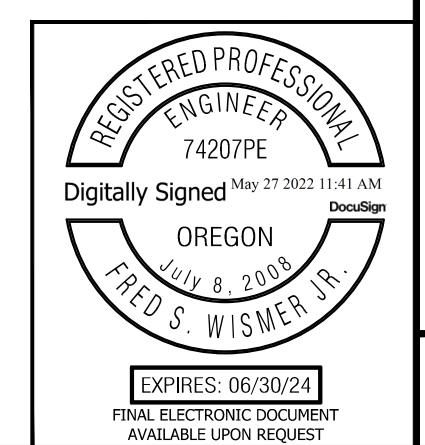
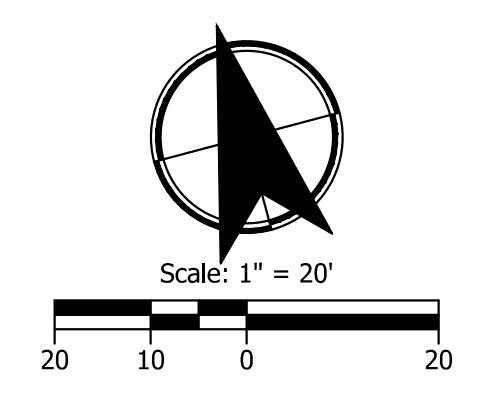

KITTELSON & ASSOCIATES
851 SW 6TH AVENUE, SUITE 600
PORTLAND, OR 97204
P 503.228.5230 F 503.273.8169

NO.	DATE	REVISION	APP'D.
0	05/25/22	ISSUE FOR CONSTRUCTION	FSW

Submission Date: 03/07/2022
Drawn: JCB/RMM, Designed: NRS/JBK, Checked: FSW

PROJECT NO. 2015-001-20

W. Hayes Street Improvements
Cascade Avenue to Settlemier Avenue
WATER QUALITY PLAN - BIORETENTION POND

SHEET NO. 2G

Plot Stamp: 5/25/2022 3:55:05 PM - Fred Wismer
File: H:\24\24512 - W. Hayes Street\design\CD\CD-Water Quality Plans-24512.dwg

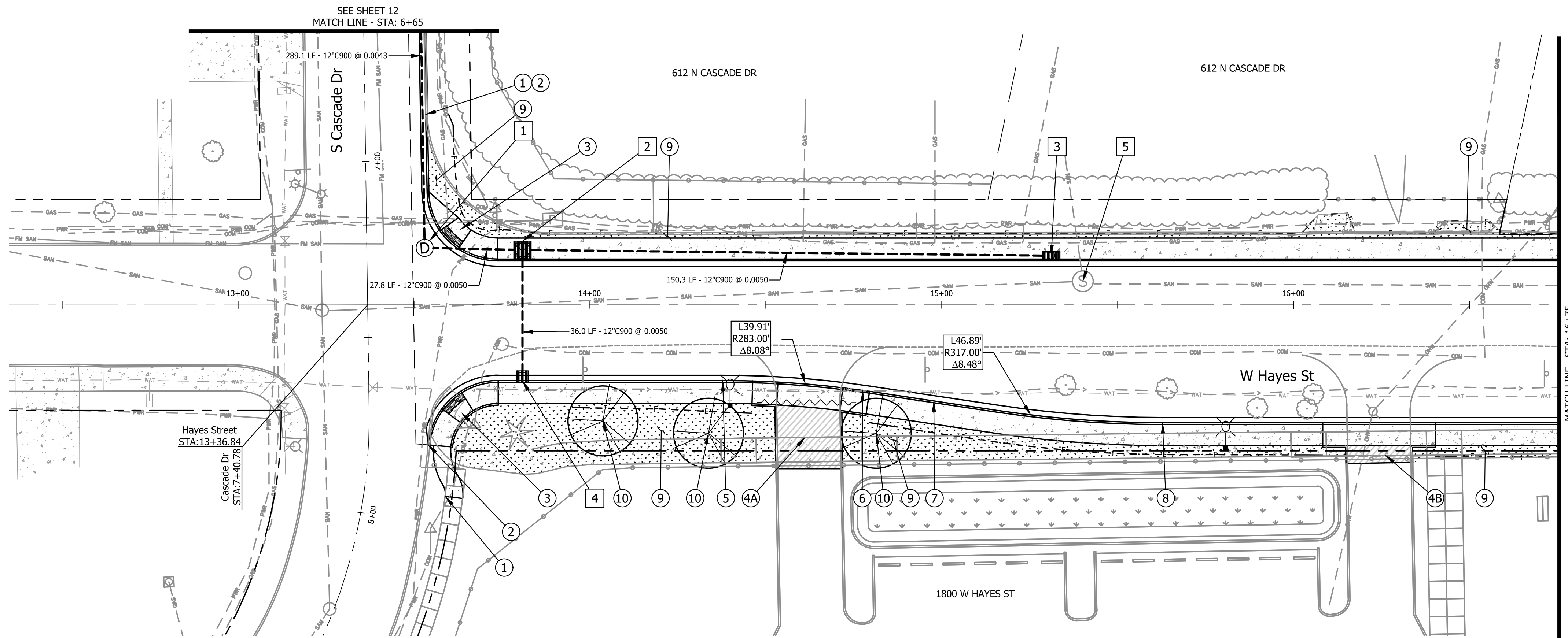

STREET CONSTRUCTION NOTES

- ① Construct Std. Curb & Gutter, & Sidewalk Match Existing (For Details, See Sht. 2B)
- ② Sawcut & Remove Extg. Pavement, Curb & Gutter, & Sidewalk
- ③ Construct Parallel Sidewalk Ramp (2 Ea.) (For Standard Details, See Sht. 2B-6)
- ④ Construct Driveway
A - Sta. 14+46.27, 21.63'Rt - Sta. 14+79.48, 24.59'Rt
B - Sta. 16+08.29, 33.50'Rt - Sta. 16+40.29, 33.50'Rt (For Details, See Sht. 2B)
- ⑤ Curb Point of Curvature STA: 14+37.76, 21.50'Rt.
- ⑥ Curb Point of Tangency STA: 14+77.54, 24.31'Rt.
- ⑦ Curb Point of Curvature STA: 15+16.04, 30.04'Rt.
- ⑧ Curb Point of Tangency STA: 15+60.57, 33.50'Rt.
- ⑨ Install Permanent Lawn Seeding (±3,210 SF)
- ⑩ Install Permanent Street Tree 'Kwanzan Cherry Plum' [Prunus 'Kwanza'] (3 Ea.) (For Details, See Sht. 2B)
STA: 14+03.73, 33.00'Rt.
STA: 14+33.72, 36.50'Rt.
STA: 14+81.38, 36.50'Rt.

STORM CONSTRUCTION NOTES

- ① Install 48" Flat-Top Manhole (1 Ea.), Rotate Cone so Manhole entrance is within Roadway (For Details, See Sht. 2B-3)
- ② Install CG-48 Manhole Inlet (1 Ea.) (For Details, See Sht. 2B-4)
- ③ Install CG-48 Inlet (1 Ea.) (For Details, See Sht. 2B-4)
- ④ Install CG-2 Inlet (1 Ea.) (For Details, See Sht. 2B-3)
- ⑤ Adjust to Grade (Major) (1 Ea.) (For Details, See Sht. 2B-3)

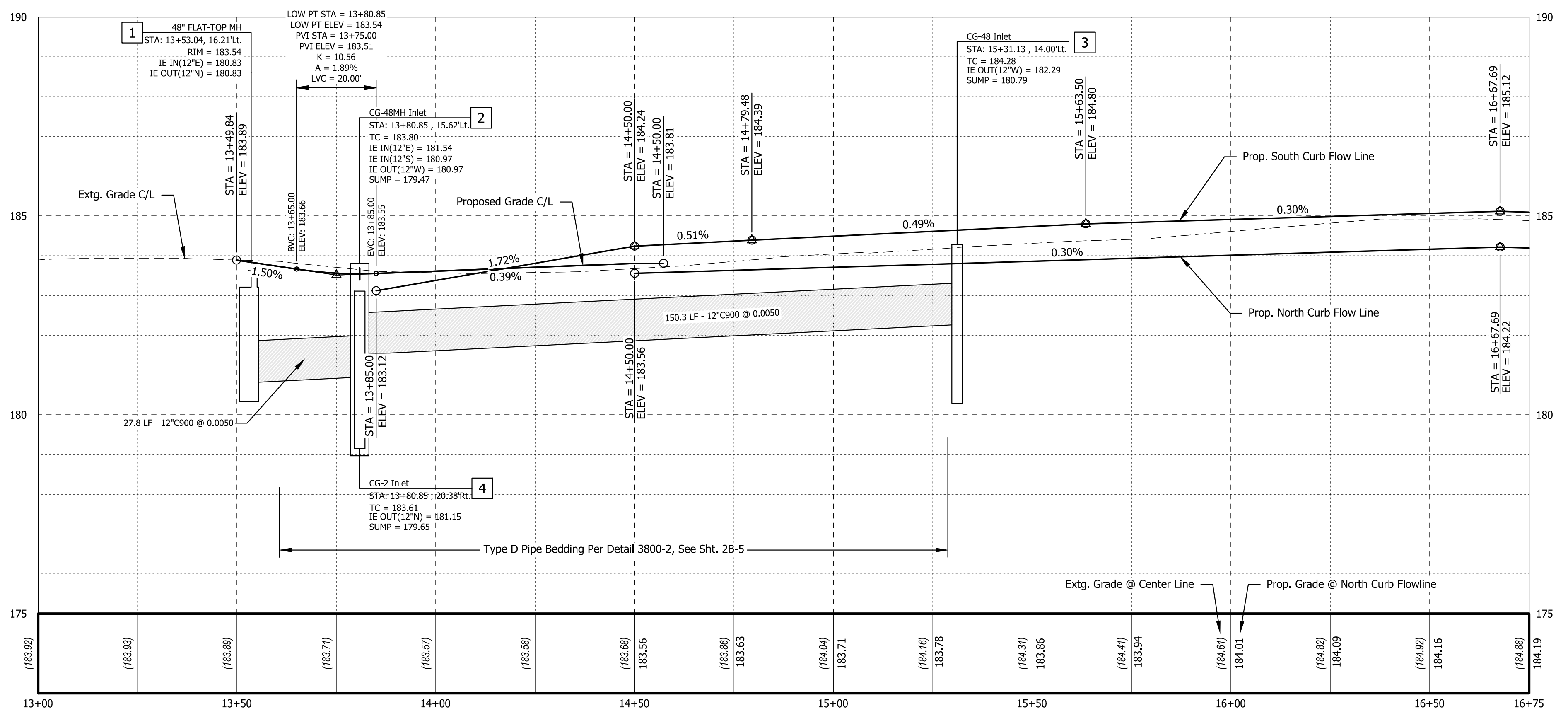

Hayes Street Profile
Horz: 1"=20', Vert: 1"=2'

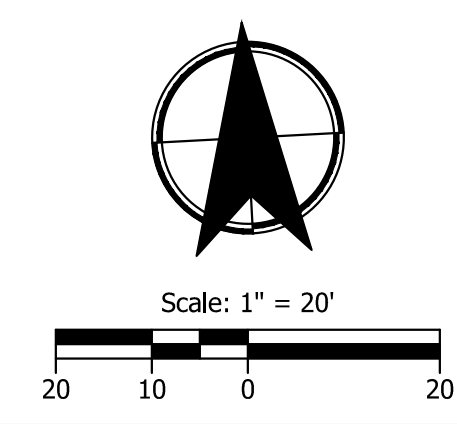

Earthworks	Excavation	617.4 CY
	Embankment	27.5 CY

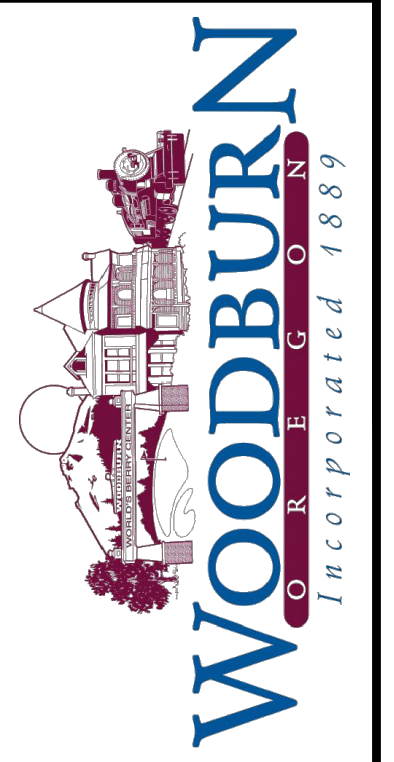
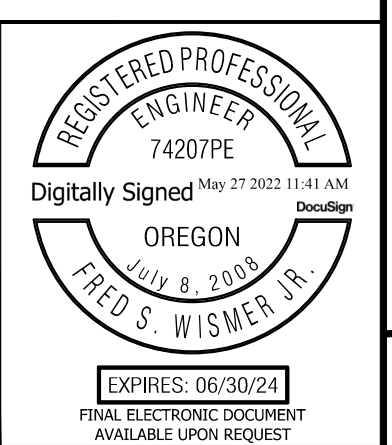

KITTELSON & ASSOCIATES
851 SW 6TH AVENUE, SUITE 600
PORTLAND, OR 97204
P 503.228.5230 F 503.273.8169

#	DATE	REVISION	FSW	APP'D
0	05/25/22	ISSUE FOR CONSTRUCTION		

Submission Date: 03/07/2022
Drawn: JCB/RMM, Designed: NRS/JBK, Checked: FSW
PROJECT NO. 2015-001-20

W. Hayes Street Improvements
Cascade Avenue to Settlemier Avenue
HAYES PLAN AND PROFILE
SHEET NO. 3

Plot Stamp: 5/27/2022 11:30:18 AM - Fred Wismer
File: H:\24\24512 - W. Hayes Street\design\CD\CD-Street\Plans-24512.dwg

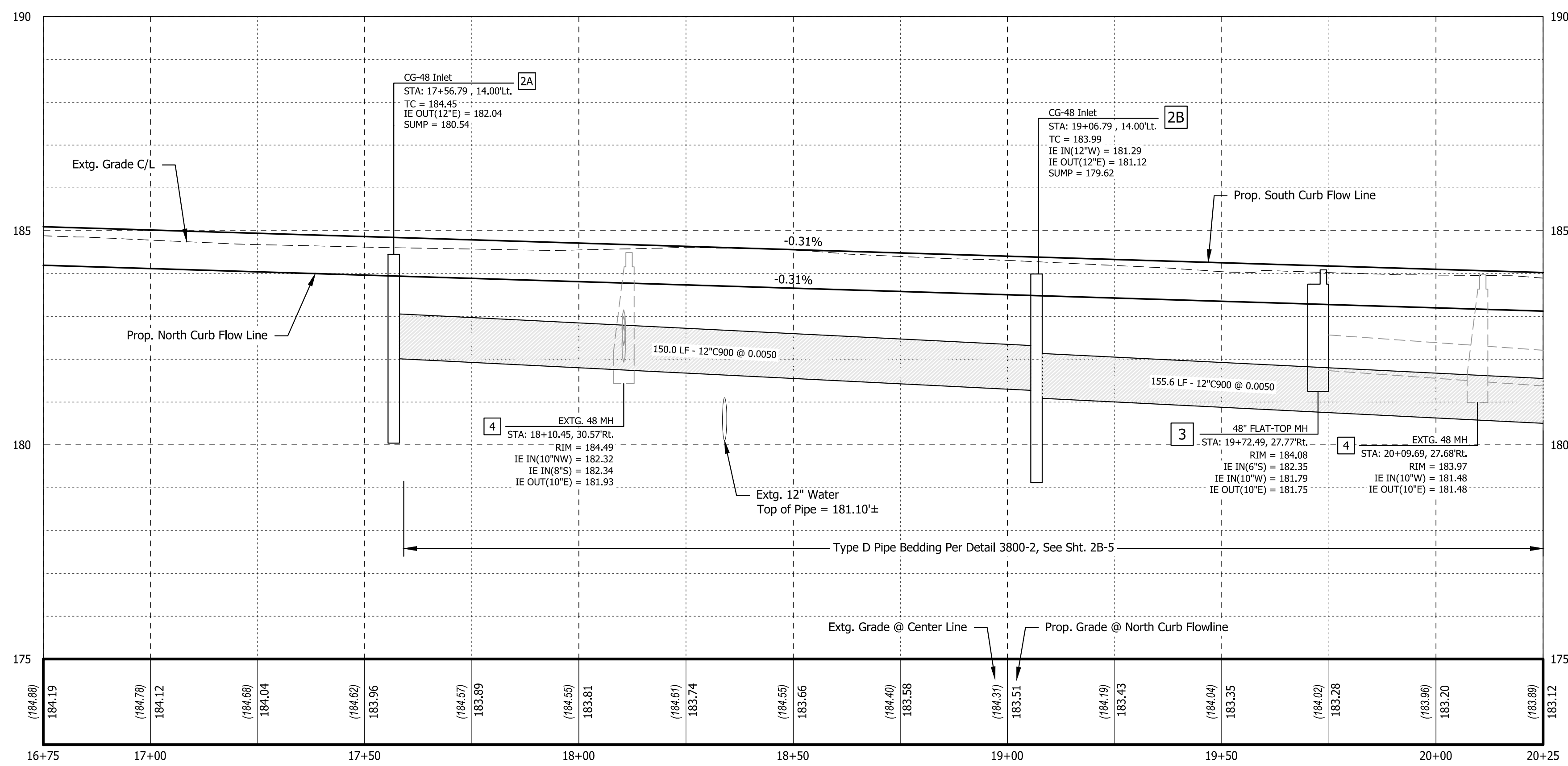
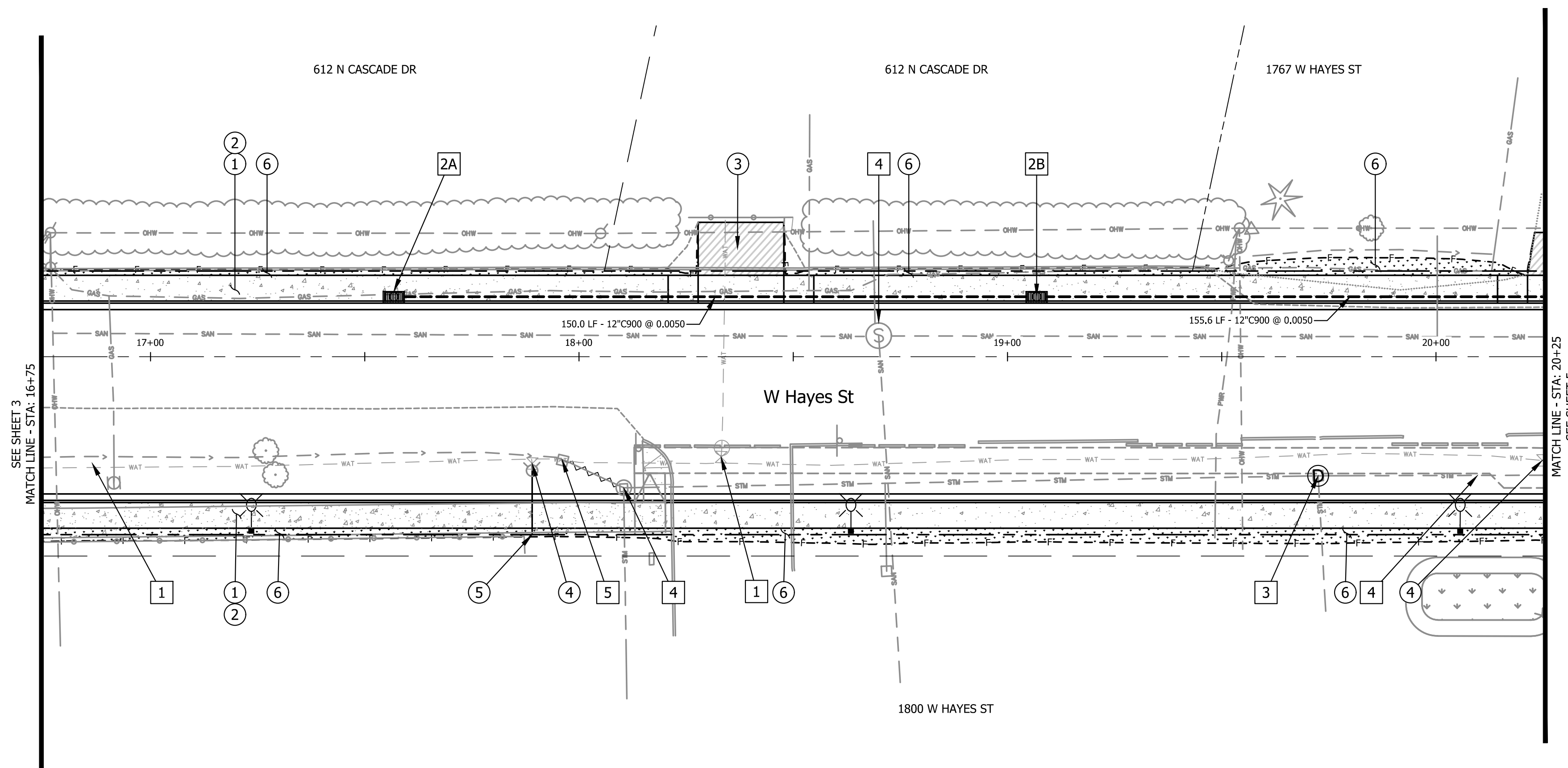

Hayes Street Profile
Horz: 1"=20', Vert: 1"=2'

STREET CONSTRUCTION NOTES

- ① Construct Std. Curb & Gutter, & Sidewalk (For Details, See Sht. 2B)
- ② Remove Extg. Pavement, Curb & Gutter, & Sidewalk
- ③ Construct Driveway Sta. 18+20.79, 12.50'Lt - Sta. 18+54.79, 12.50'Lt (For Details, See Sht. 2B)
- ④ Adjust Water Valve to Grade (Minor) (2 Ea.)
- ⑤ Construct Fire Hydrant (For Details, See Sht. 2B-5)
- ⑥ Install Permanent Lawn Seeding (±1,880 SF)

STORM CONSTRUCTION NOTES

- ① Adjust Water Valve to Grade (Minor)(1 Ea.)
- ② Install CG-48 Inlet (2 Ea.) (For Details, See Sht. 2B-4)
- ③ Remove Extg. Inlet and Install 48" Flat Top Manhole (1 Ea.) (For Details, See Sht. 2B-3)
- ④ Adjust Manhole Rim to Grade (Major)(2 Ea.)
- ⑤ Remove Catch Basin (1 Ea.)

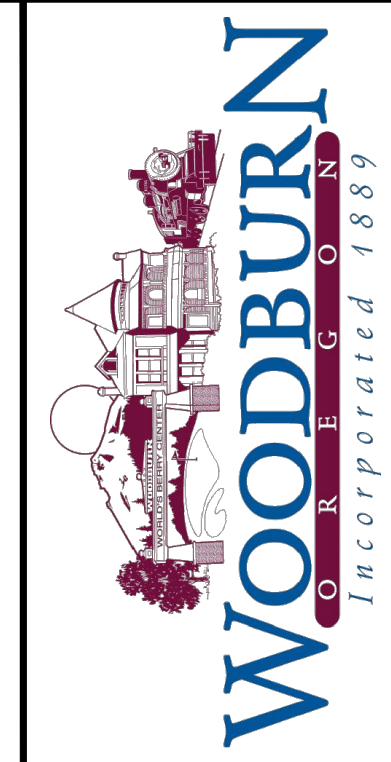

KITTELSON & ASSOCIATES
851 SW 6TH AVENUE, SUITE 600
PORTLAND, OR 97204
P 503.228.5230 F 503.273.8169

NO.	DATE	REVISION	APP'D.
0	05/25/22	ISSUE FOR CONSTRUCTION	FSW

Submission Date: 03/07/2022
Drawn: JCB/RMM, Designed: NRS/JBK, Checked: FSW
PROJECT NO. 2015-001-20

W. Hayes Street Improvements
Cascade Avenue to Settlemier Avenue
HAYES PLAN AND PROFILE

SHEET NO. 4

Earthworks
Excavation 862.3 CY
Embankment 37.4 CY

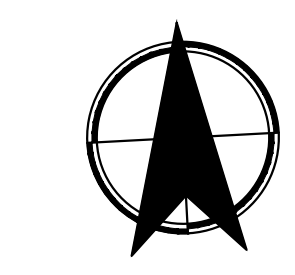
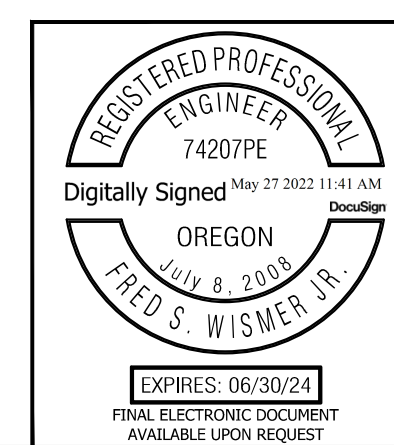

#	DATE	REVISION	ISSUE FOR CONSTRUCTION	FSW	APP'D

Submission Date: 03/07/2022

Drawn: JCB/RMM Designed: NRS/JBK Checked: FSW

PROJECT NO. 2015-001-20

W. Hayes Street Improvements
Cascade Avenue to Settlemier Avenue

HAYES PLAN AND PROFILE

SHEET NO. 5

STREET CONSTRUCTION NOTES

- ① Construct Driveway
A - Sta. 20+14.34, 12.50'Lt. - Sta. 20+41.34, 12.50'Lt.
B - Sta. 21+01.87, 12.50'Lt. - Sta. 21+35.87, 12.50'Lt.
C - Sta. 22+81.09, 12.50'Lt. - Sta. 23+19.09, 12.50'Lt.
D - Sta. 23+88.79, 13.33'Lt. - Sta. 24+02.74, 13.33'Lt.
E - Sta. 22+16.59, 33.50'Rt. - Sta. 22+30.59, 33.50'Rt.
F - Sta. 22+73.83, 33.50'Rt. - Sta. 22+87.83, 33.50'Rt.
(For Details, See Sht. 2B)
- ② Construct Std. Curb & Gutter, & Sidewalk (For Details, See Sht. 2B)
- ③ Construct Std. Curb & Gutter (For Details, See Sht. 2B)
- ④ Construct Std. Sidewalk Match Existing (For Details, See Sht. 2B)
- ⑤ Sawcut and Remove Extg. Pavement, Curb & Gutter, & Sidewalk
- ⑥ Remove Extg. Pavement, Curb & Gutter, & Sidewalk
- ⑦ Adjust Water Valve to Grade (Minor) (3 Ea.)
- ⑧ Construct Parallel Sidewalk Ramp (5 Ea.) (For Detailed Grading, See Sht. 2B-6)
- ⑨ Construct Doweled Median Island (For Details, See Sht. 2B-2)
- ⑩ Remove Extg. Mailbox Upon Installation of the Proposed Mailbox Cluster
- ⑪ Prop. Light Fixture (Refer to Sheets IL-2 Thru IL-6)
- ⑫ Curb Point of Curvature STA: 23+49.24, 33.50'Rt.
- ⑬ Curb Point of Tangency STA: 23+95.51, 28.35'Rt.
- ⑭ Curb Point of Curvature STA: 24+33.83, 19.84'Rt.
- ⑮ Curb Point of Tangency STA: 24+73.47, 15.50'Rt.
- ⑯ Curb Point of Curvature STA: 23+49.24, 12.50'Lt.
- ⑰ Curb Point of Tangency STA: 23+57.43, 12.73'Lt.
- ⑱ Curb Point of Curvature STA: 24+62.15, 18.20'Lt.
- ⑲ Curb Point of Tangency STA: 24+73.47, 18.50'Lt.
- ⑳ Preserve and Protect Culvert
- ㉑ See Sht. TS-4 for RRRFB Plan
- ㉒ Construct Fire Hydrant STA: 20+29.30, 41.50' Rt. Back of Walk Elevation = 184.62 (For Details, See Sht. 2B-5)
- ㉓ Water Meter Relocation, By City Forces (1 Ea.)
- ㉔ Install Permanent Lawn Seeding (±3,028 SF)
- ㉕ Salvage and Reinstall Existing Church Sign. Contractor to expose, connect, and extend existing conduit & wiring to relocated sign. Contractor to coordinate power shutdown with church.

STORM CONSTRUCTION NOTES

- 1 Install CG-48 Inlet (1 Ea.) (For Details, See Sht. 2B-4)
- 2 Adjust Manhole Rim to Grade (Major) (3 Ea.)
- 3 Install CG-48 Manhole Inlet (2 Ea.) (For Details, See Sht. 2B-4)
- 4 Install 48 In. Flat Top Manhole (3 Ea.) (For Details, See Sht. 2B-3)
- 5 Remove Extg. Inlet (1 Ea.)
- 6 Adjust Water Service Vertically
- 7 Connect to Extg. Structure (1 Ea.)
- 8 Install Manhole over Extg. Sewer (1 Ea.)

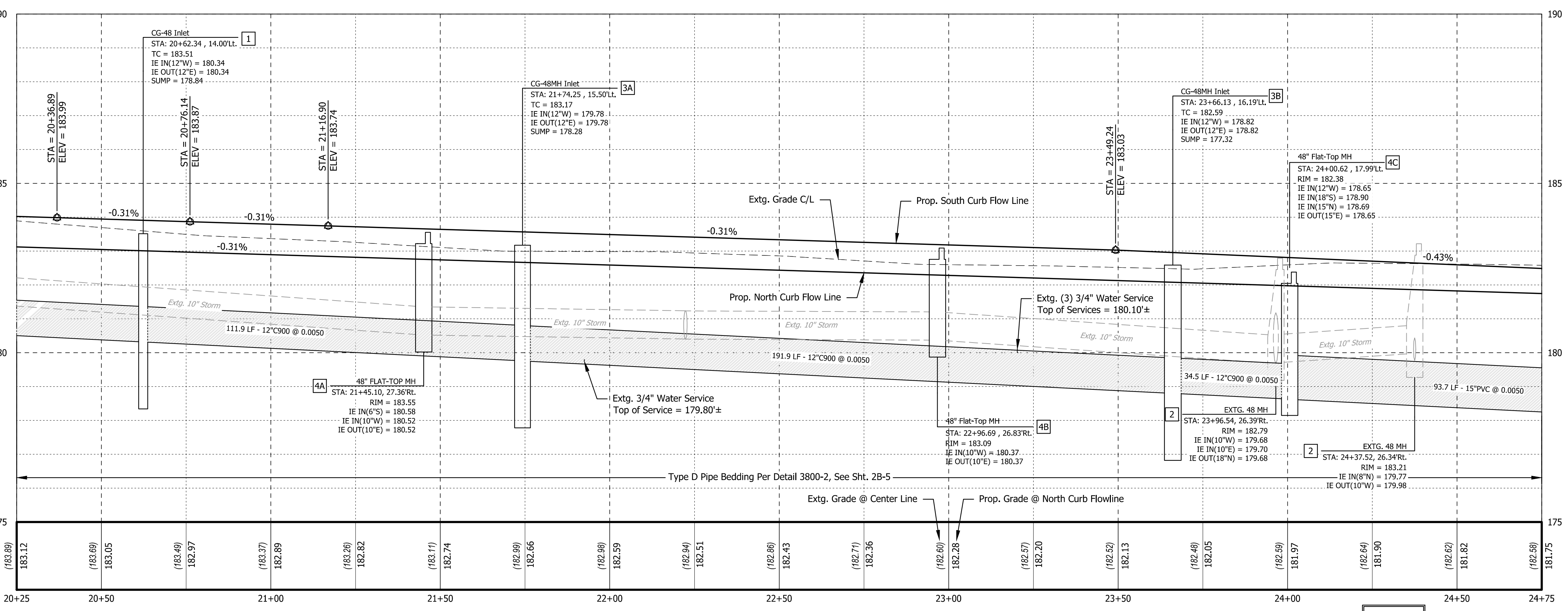
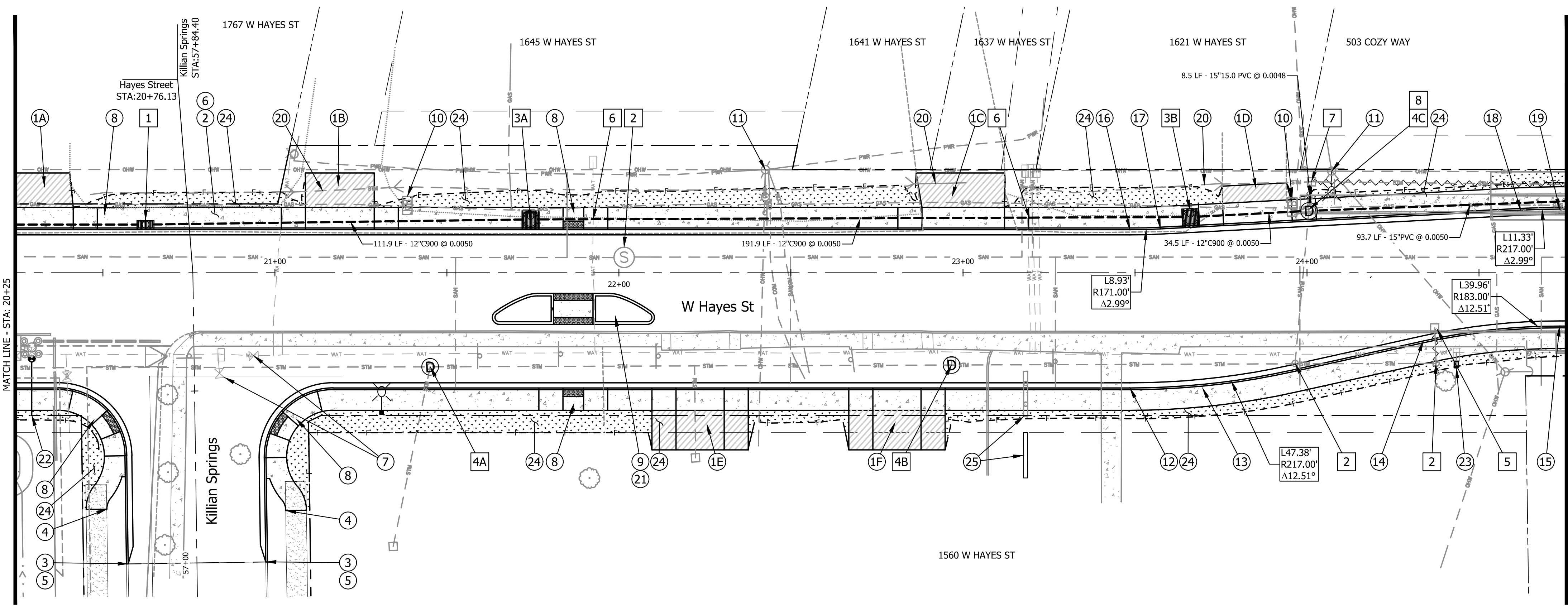
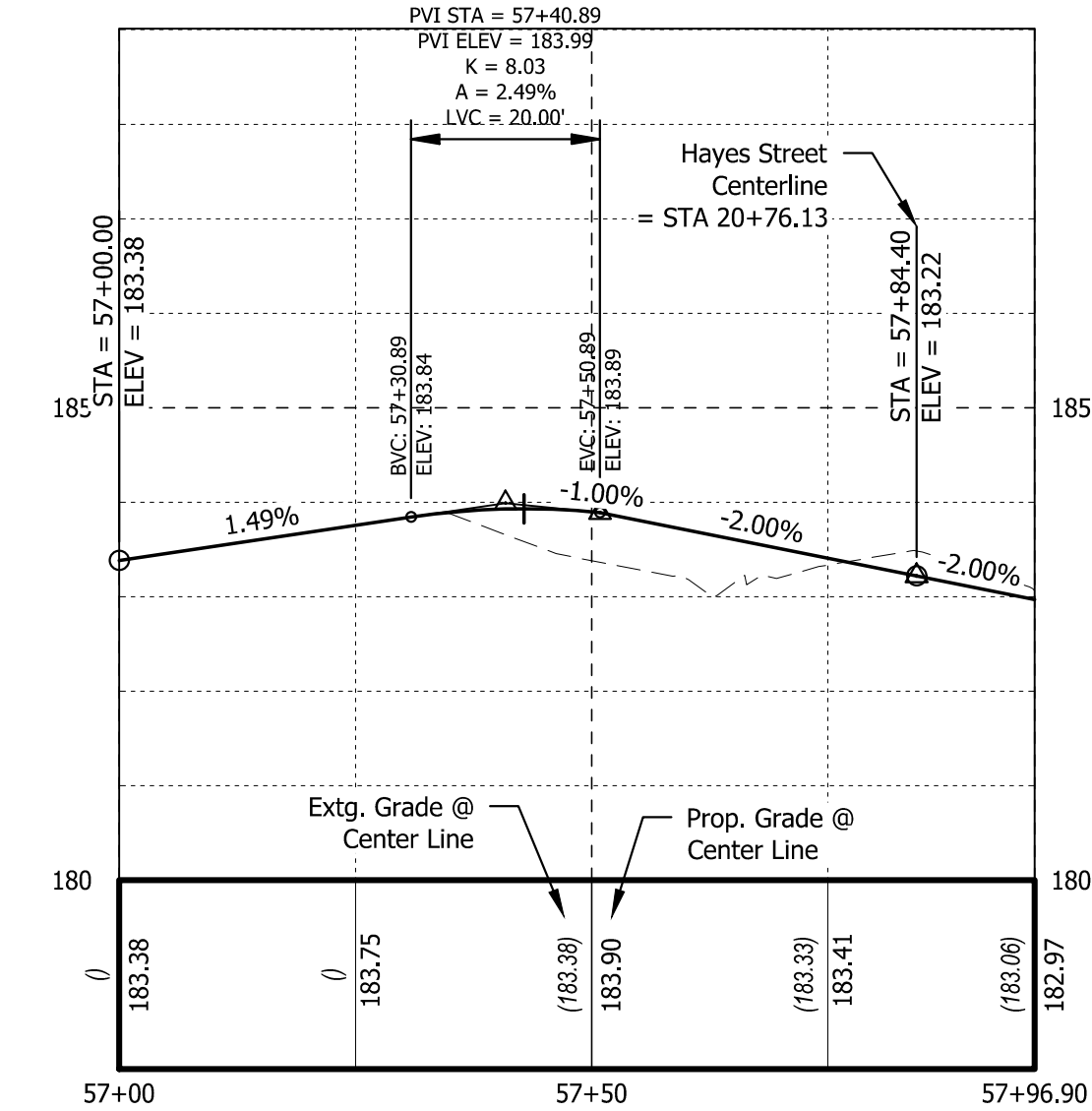

Earthworks
Excavation
961.8 CY
Embankment
73.5 CY

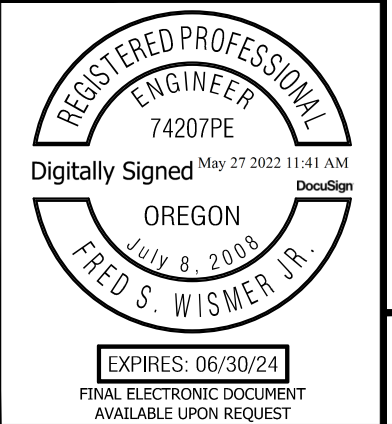
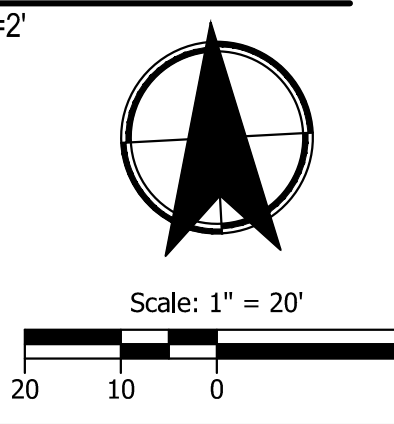

Plot Stamp: 5/27/2022 11:30:40 AM - Fred Wismer
File: H:\24\24512 - W. Hayes Street\design\CD\CD-Street_Plans-24512.dwg

Plot Stamp: 5/27/2022 11:30:51 AM - Fred Wismer
 File: H:\24\24512 - W. Hayes Street\design\CD\CD-Street\Plans-24512.dwg

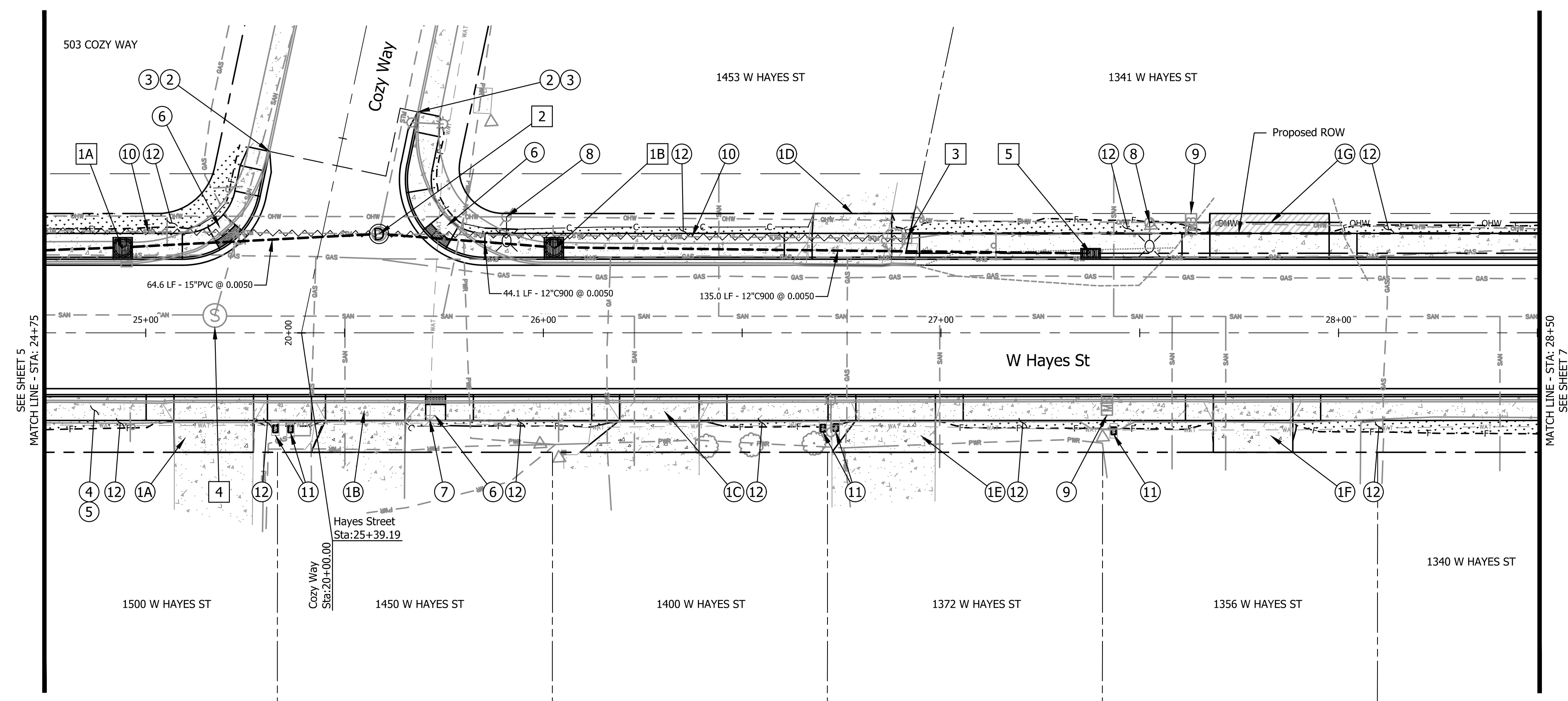

STREET CONSTRUCTION NOTES

- ① Construct Driveway
 A - Sta. 25+00.12, 15.50 'Rt. - Sta. 26+12.18, 15.50 'Rt.
 B - Sta. 25+41.72, 15.53 'Rt. - Sta. 25+65.22, 15.50 'Rt.
 C - Sta. 26+12.18, 15.50 'Rt. - Sta. 26+46.18, 15.50 'Rt.
 D - Sta. 26+60.62, 18.50 'Lt. - Sta. 26+94.62, 18.50 'Lt.
 E - Sta. 26+71.60, 15.50 'Rt. - Sta. 27+05.60, 15.50 'Rt.
 F - Sta. 27+61.50, 15.50 'Rt. - Sta. 27+95.50, 15.50 'Rt.
 G - Sta. 27+60.63, 18.50 'Lt. - Sta. 28+04.63, 18.50 'Lt.
 (For Details, See Sht. 2B)
- ② Construct Std. Curb & Gutter, & Sidewalk
 Match Existing
 (For Details, See Sht. 2B)
- ③ Sawcut and Remove Extg. Pavement, Curb & Gutter, & Sidewalk
- ④ Construct Std. Curb & Gutter, & Sidewalk
 (For Details, See Sht. 2B)
- ⑤ Remove Extg. Pavement, Curb & Gutter, & Sidewalk
- ⑥ Construct Parallel Sidewalk Ramp (3 Ea.)
 (For Detailed Grading, See Sht. 2B-6)
- ⑦ Adjust Water Valve to Grade (Minor) (2 Ea.)
- ⑧ Prop. Light Fixture
 (Refer to Sheets IL-2 Thru IL-6)
- ⑨ Remove Extg. Mailbox Upon Installation of the Proposed Mailbox Cluster
- ⑩ Abandon Extg. Sewer Line
- ⑪ Water Meter Relocation, By City Forces (Ea. 5)
- ⑫ Install Permanent Lawn Seeding (±1,350 SF)

STORM CONSTRUCTION NOTES

- ① Install CG-48 Manhole Inlet (2 Ea.)
 (For Details, See Sht. 2B-4)
- ② Install 48 In. Flat Top Manhole (1 Ea.)
 Install over Extg. Sewer (1 Ea.)
 (For Details, See Sht. 2B-3)
- ③ Remove Extg. Inlet
- ④ Adjust Manhole Rim to Grade (Major) (1 Ea.)
- ⑤ Install CG-48 Inlet
 (For Details, See Sht. 2B-4)

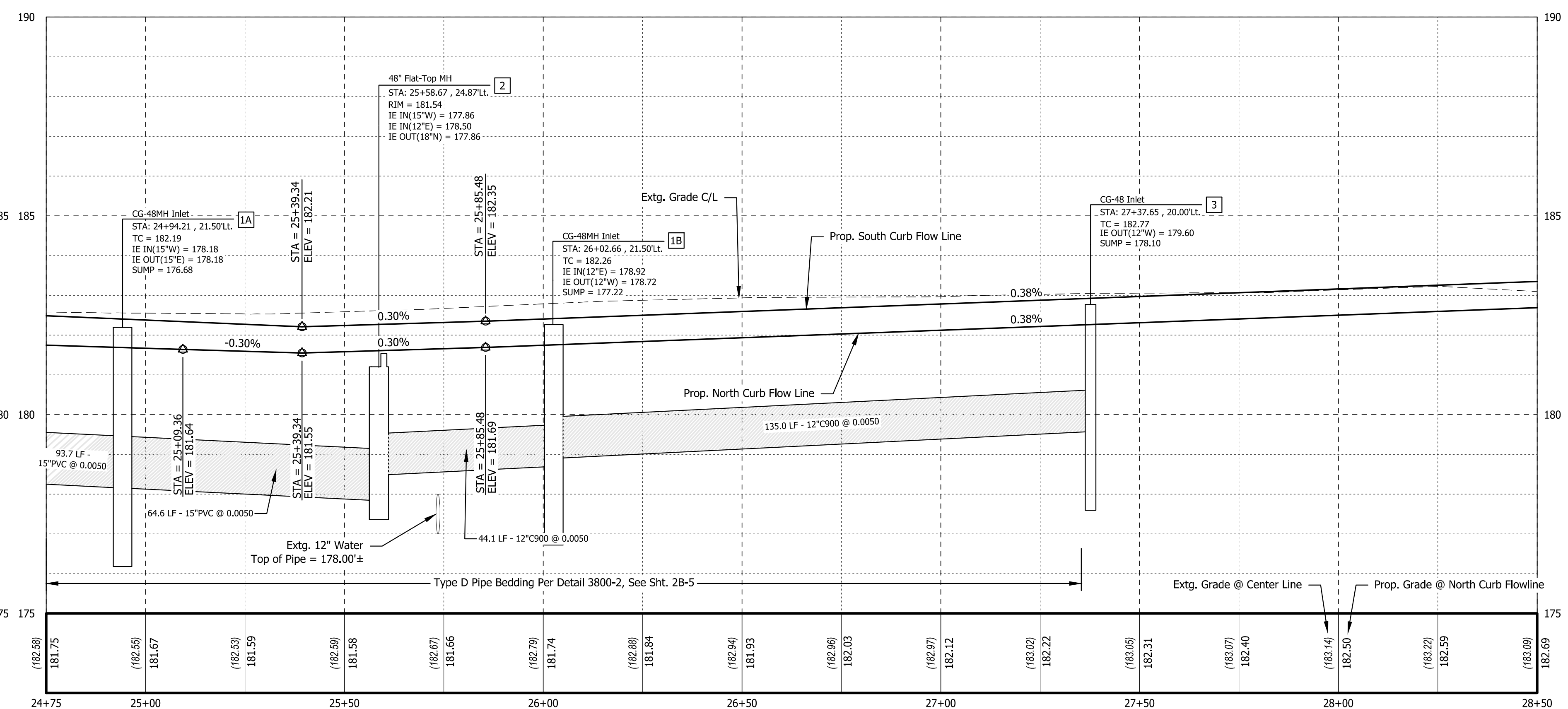
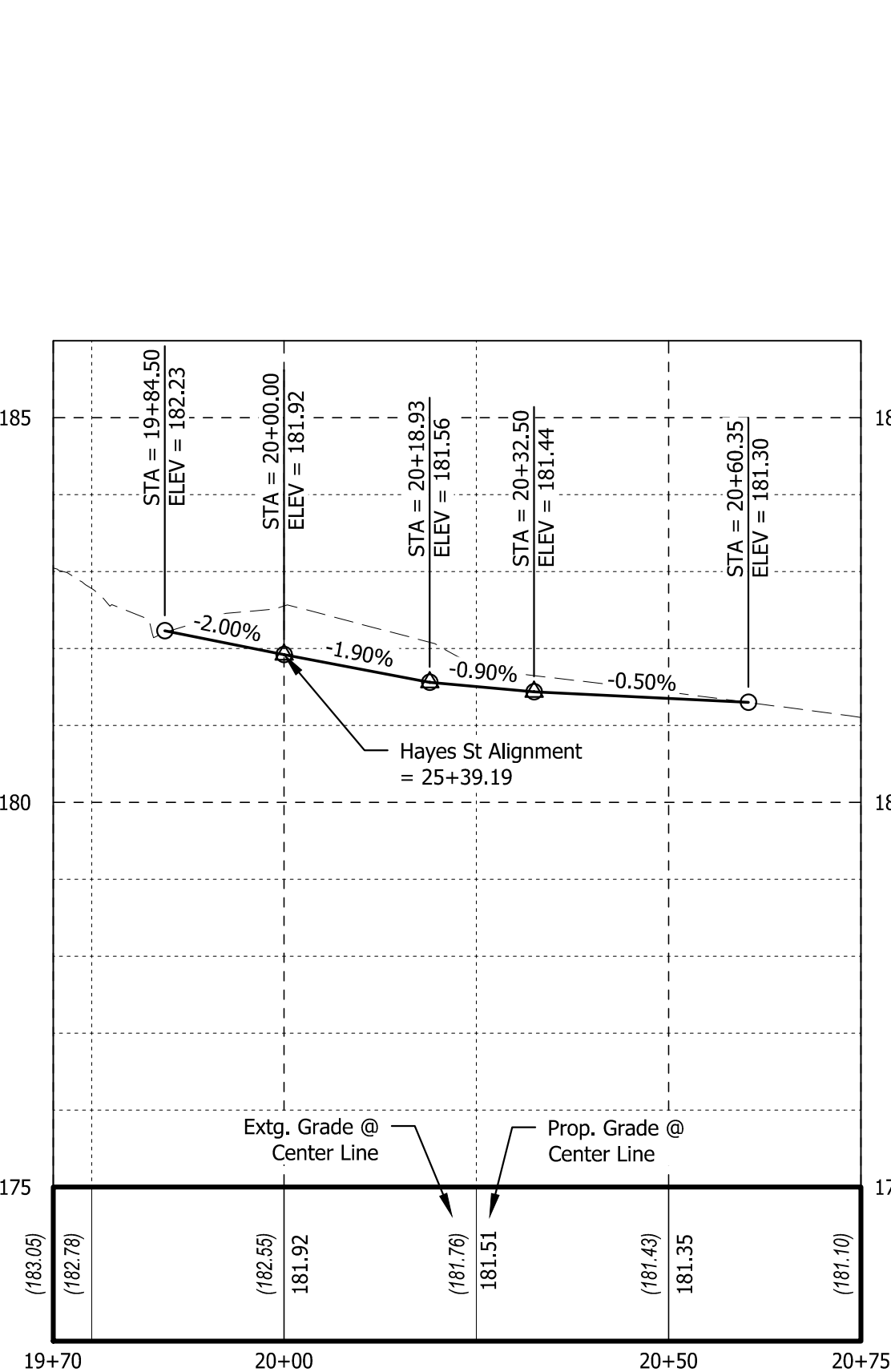

Cozy Way Connection Profile

Hayes Street Profile

Horz: 1"=20', Vert: 1"=2'

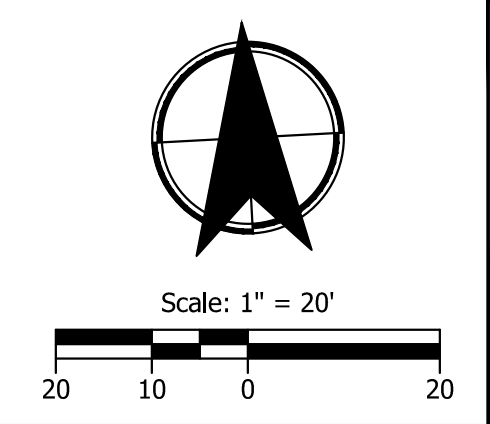

Earthworks	Excavation	954.8 CY
Embankment		18.3 CY

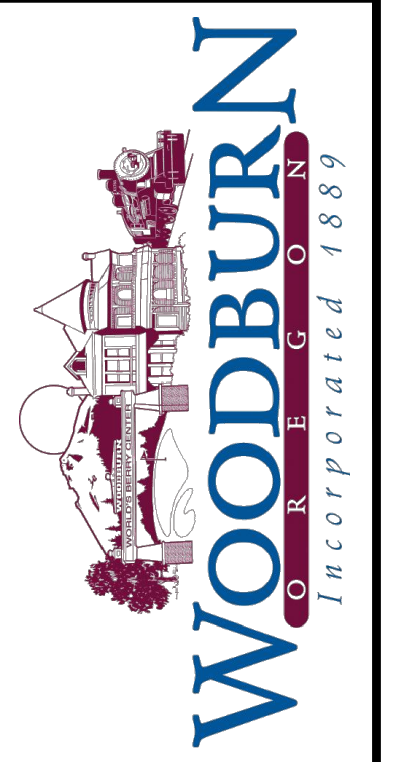
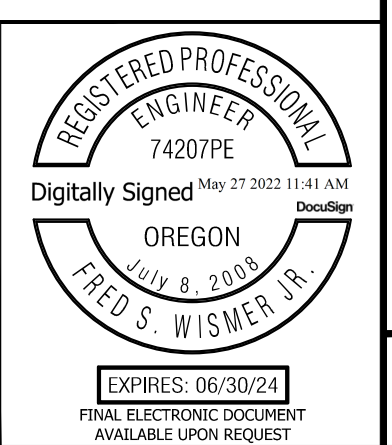

KITTELSON & ASSOCIATES
 851 SW 6TH AVENUE, SUITE 600
 PORTLAND, OR 97204
 P 503.228.5230 F 503.273.8169

DATE	REVISION	APP'D
05/25/22	ISSUE FOR CONSTRUCTION	FSW

Submission Date: 03/07/2022
 Drawn: JCB/RMM, Designed: NRS/JBK, Checked: FSW

PROJECT NO. 2015-001-20

W. Hayes Street Improvements
 Cascade Avenue to Settlemier Avenue
 HAYES PLAN AND PROFILE

NO.	DATE	REVISION	APP'D
0	05/25/22	ISSUE FOR CONSTRUCTION	FSW

Submission Date: 03/07/2022
 Drawn: JCB/RMM Designed: NRS/JBK Checked: FSW

PROJECT NO. 2015-001-20

W. Hayes Street Improvements
 Cascade Avenue to Settlemier Avenue

HAYES PLAN AND PROFILE

SHEET NO. 7

STREET CONSTRUCTION NOTES

- ① Construct Driveway
 A - Sta. 28+50.61, 15.50'Rt. - Sta. 28+83.61, 15.50'Rt
 B - Sta. 28+74.30, 18.50'Lt. - Sta. 29+04.30, 18.50'Lt.
 C - Sta. 29+64.77, 18.50'Lt. - Sta. 29+91.77, 18.50'Lt.
 D - Sta. 30+33.83, 15.50'Rt. - Sta. 30+67.83, 15.50'Rt.
 E - Sta. 30+66.09, 18.50'Lt. - Sta. 31+04.09, 18.50'Lt.
 F - Sta. 31+38.30, 15.50'Rt. - Sta. 31+72.30, 15.50'Rt.
 G - Sta. 31+87.29, 15.50'Rt. - Sta. 32+19.29, 15.50'Rt.
 H - Sta. 31+99.77, 18.50'Lt. - Sta. 32+33.77, 18.50'Lt.
 (For Details, See Sht. 2B)
- ② Construct Std. Curb & Gutter Match Existing (For Details, See Sht. 2B)
- ③ Construct Std. Sidewalk Match Existing (For Details, See Sht. 2B)
- ④ Construct Std. Curb & Gutter, & Sidewalk Match Existing (For Details, See Sht. 2B)
- ⑤ 5.0' Transition from Std. Curb & Gutter to Std. Curb
- ⑥ Remove Extg. Pavement, Curb & Gutter, & Sidewalk
- ⑦ Construct Parallel Sidewalk Ramp (3 Ea.) (For Detailed Grading, See Sht. 2B)
- ⑧ Prop. Light Fixture (Refer to Sheets IL-2 Thru IL-6)
- ⑨ Remove Extg. Mailbox Upon Installation of the Proposed Mailbox Cluster
- ⑩ Water Meter Relocation, By City Forces (Ea. 11)
- ⑪ Adjust Fire Hydrant to Grade (1 Ea.) Finish Grade at Base is 182.73.
- ⑫ Construct Std. Curb, Match Existing STA: 29+07.02, 99.93' Rt. (For Details, See Sht. 2B)
- ⑬ End Std. Curb, Match Existing STA: 29+41.03, 100.08' Rt. (For Details, See Sht. 2B)
- ⑭ Install Permanent Lawn Seeding (±1,975 SF)

STORM CONSTRUCTION NOTES

- ① Adjust Manhole Rim to Grade (Major) (1 Ea.)
- ② Install CG-48 Inlet Catch Basin (Ea. 2) (For Details, See Sht. 2B-3)

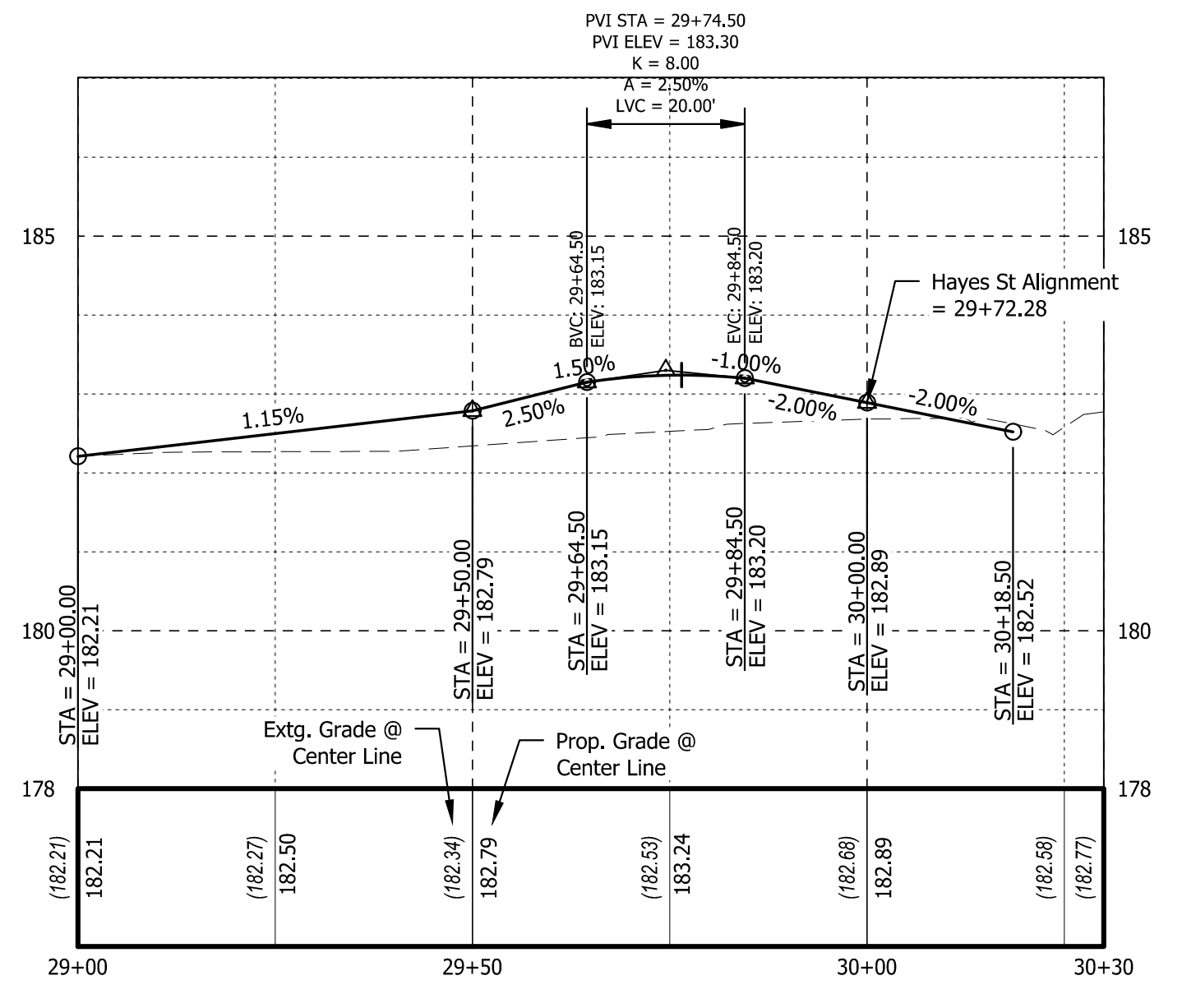
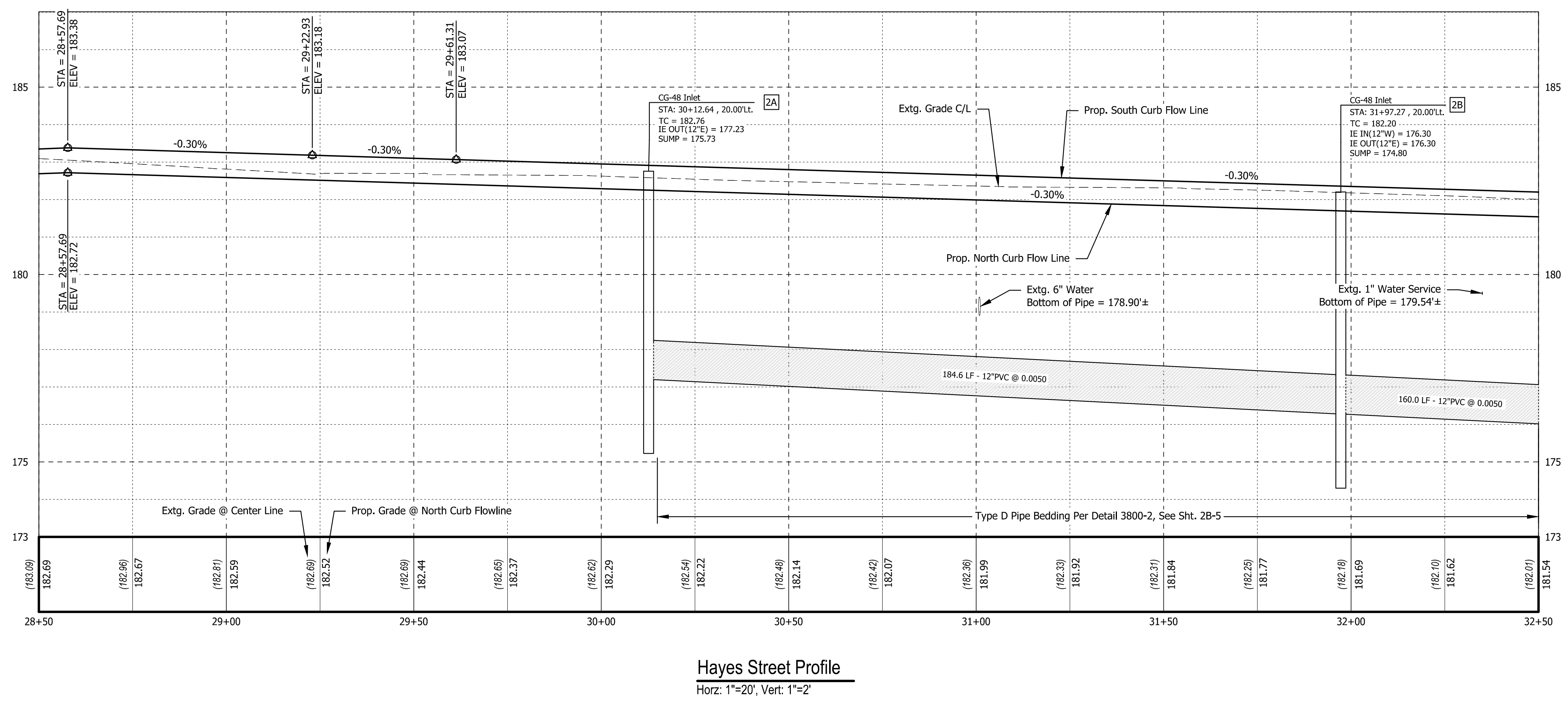
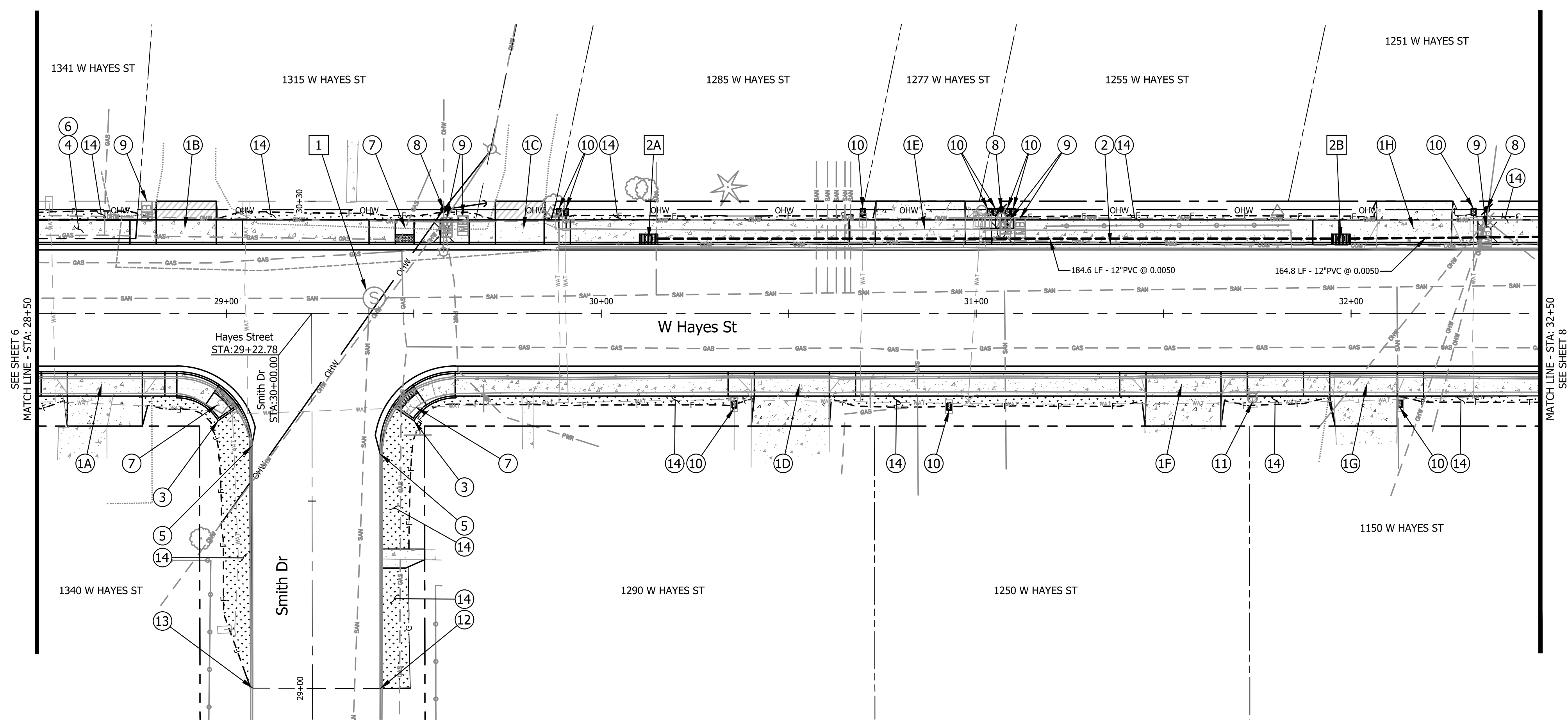

Smith Dr Connection Profile
 SCALE: 1:20

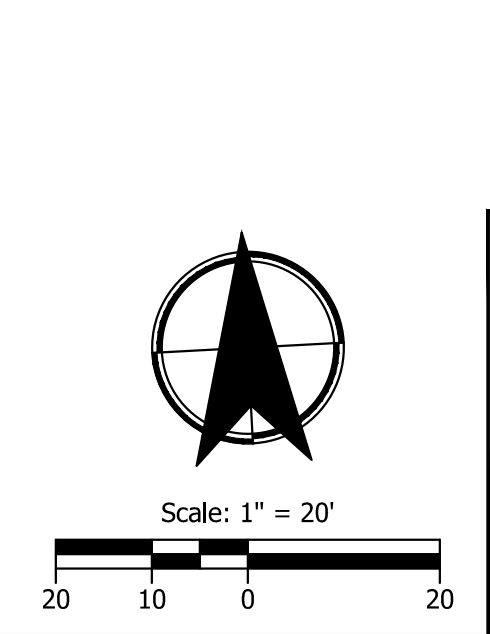

Earthworks	Excavation	819.0 CY
Embankment		22.0 CY

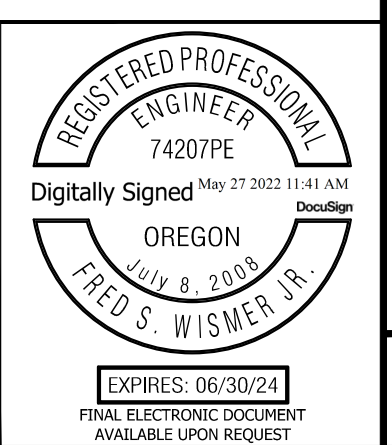

Plot Stamp: 5/27/2022 11:31:15 AM - Fred Wismer
 File: H:\24\24512 - W. Hayes Street\design_CD\CD-Street-Plans-24512.dwg

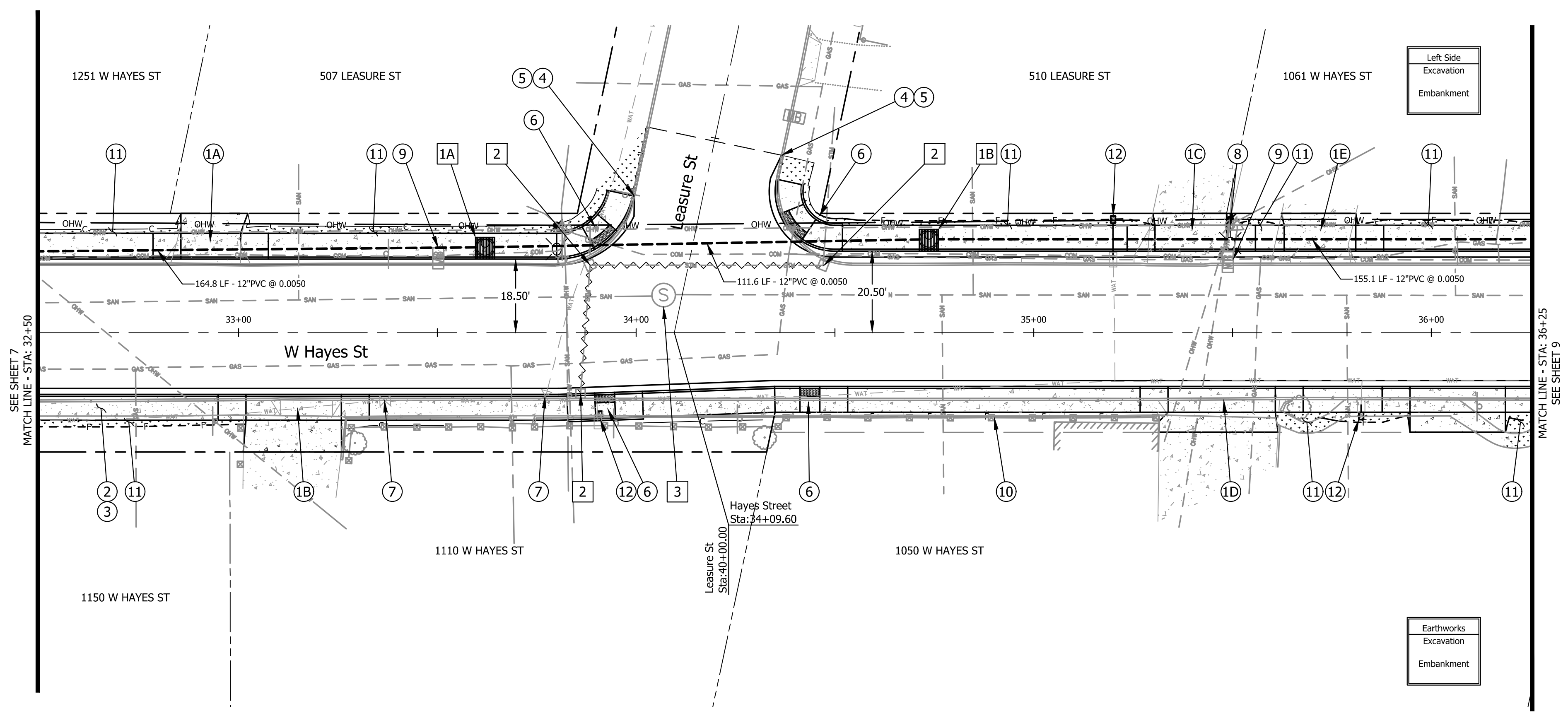

STREET CONSTRUCTION NOTES

- ① Construct Driveway
 A - Sta. 32+78.50, 18.50'Lt. - Sta. 33+07.50, 18.50'Lt
 B - Sta. 32+98.87, 15.50'Rt. - Sta. 33+32.87, 15.50'Rt.
 C - Sta. 35+23.52, 20.50'Lt. - Sta. 35+55.77, 20.50'Lt.
 D - Sta. 35+26.79, 13.50'Rt. - Sta. 35+67.79, 13.50'Rt.
 E - Sta. 35+55.77, 20.50'Lt. - Sta. 35+88.02, 20.50'Lt.
 (For Details, See Sht. 2B)
- ② Construct Std. Curb & Gutter, & Sidewalk
 Match Existing
 (For Details, See Sht. 2B)
- ③ Remove Extg. Pavement, Curb & Gutter, & Sidewalk
- ④ Construct Std. Curb & Gutter, & Sidewalk
 Match Existing
 (For Details, See Sht. 2B)
- ⑤ Sawcut and Remove Extg. Pavement, Curb & Gutter, & Sidewalk
- ⑥ Construct Parallel Sidewalk Ramp (4 Ea.)
 (For Detailed Grading, See Sht. 2B)
- ⑦ Adjust Water Valve to Grade (Minor) (2 Ea.)
- ⑧ Prop. Light Fixture
 (Refer to Sheets IL-2 Thru IL-6)
- ⑨ Remove Extg. Mailbox Upon Installation of the Proposed Mailbox Cluster
- ⑩ Retain and Protect Existing Fence
- ⑪ Install Permanent Lawn Seeding (±770 SF)
- ⑫ Water Meter Relocation, By City Forces (3 Ea.)

STORM CONSTRUCTION NOTES

- 1 Install CG-48 Manhole Inlet (2 Ea.)
 (For Details, See Sht. 2B-3)
- 2 Remove Extg. Storm Structure (2 Ea.)
- 3 Adjust Manhole Rim to Grade (Major) (1 Ea.)

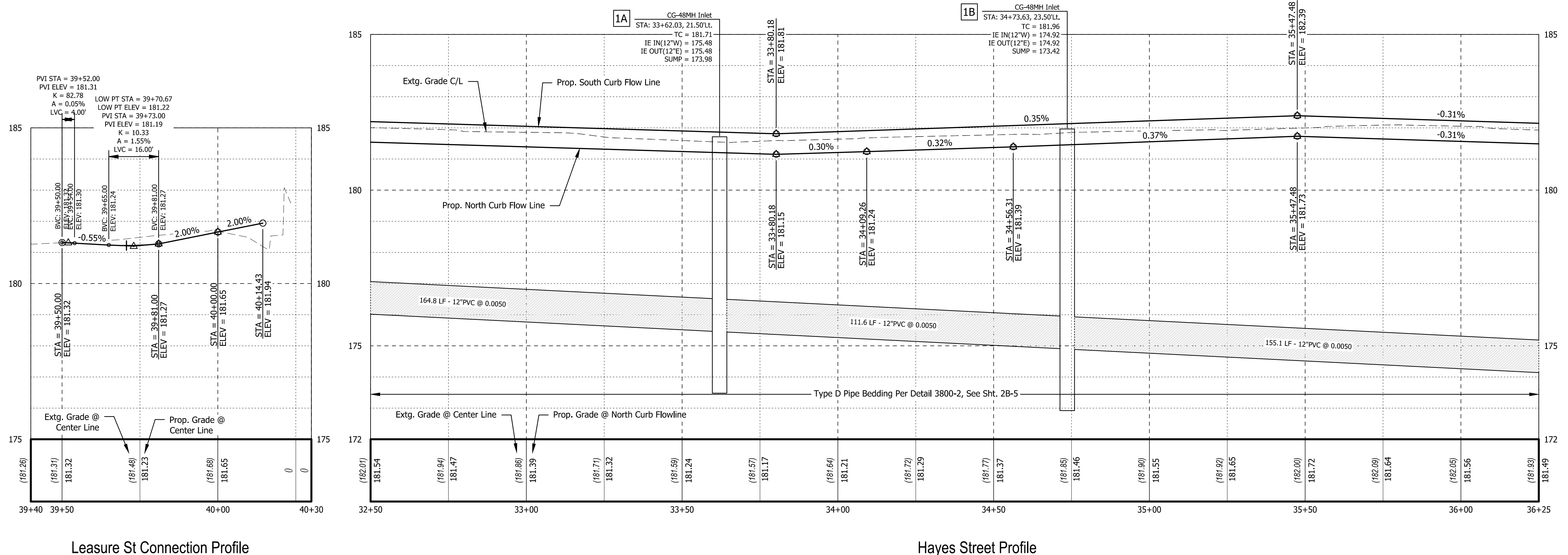

Leasure St Connection Profile

Hayes Street Profile

Horz: 1"=20', Vert: 1"=2'

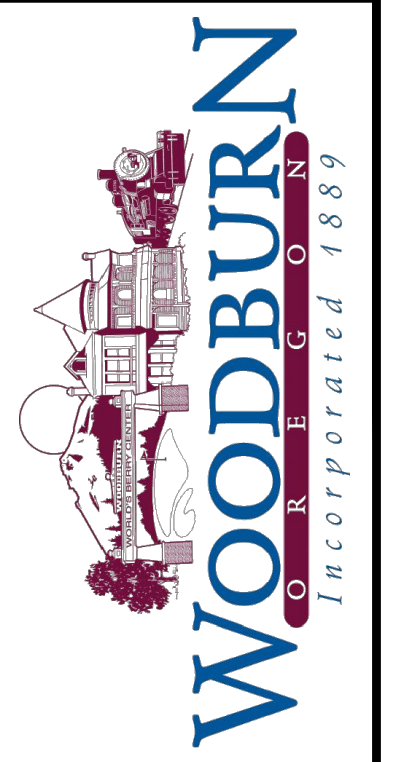
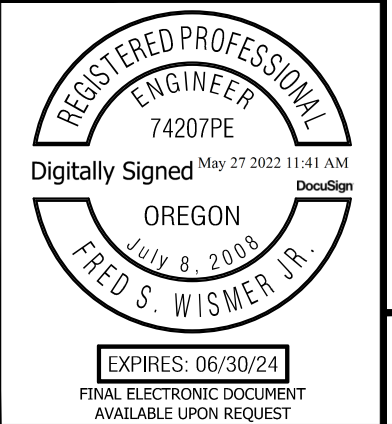
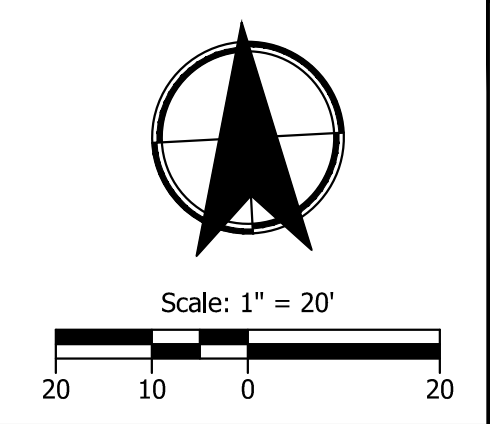

KITTELSON & ASSOCIATES
 851 SW 6TH AVENUE, SUITE 600
 PORTLAND, OR 97204
 P 503.228.5230 F 503.273.8169

NO.	REVISION	DATE	BY	APP'D.
0	ISSUE FOR CONSTRUCTION	05/25/22	FSW	APP'D.

Submission Date: 03/07/2022
 Drawn: JCB/RMM, Designed: NRS/JBK, Checked: FSW

PROJECT NO. 2015-001-20
W. Hayes Street Improvements
 Cascade Avenue to Settlemier Avenue
 HAYES PLAN AND PROFILE
 SHEET NO. 8

Plot Stamp: 5/27/2022 11:31:26 AM - Fred Wismer
 File: H:\24\24512 - W. Hayes Street\design\CD\CD-Street\Plans-24512.dwg

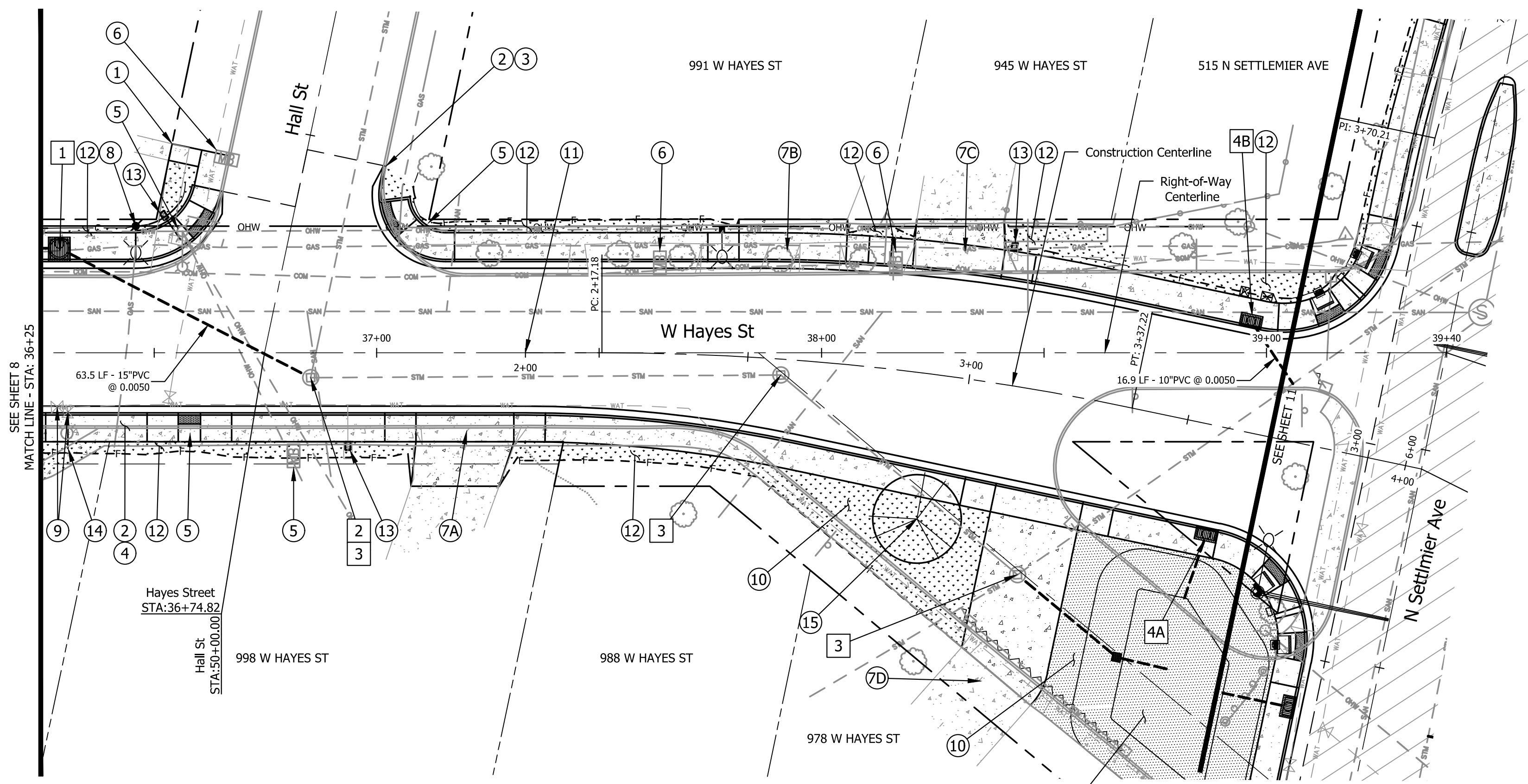

STREET CONSTRUCTION NOTES

- ① Construct Std. Sidewalk
Match Existing
(For Details, See Sht. 2B)
- ② Construct Std. Curb & Gutter, & Sidewalk
Match Existing
(For Details, See Sht. 2B)
- ③ Sawcut and Remove Extg. Pavement, Curb & Gutter, & Sidewalk
- ④ Remove Extg. Pavement, Curb & Gutter, & Sidewalk
- ⑤ Construct Parallel Sidewalk Ramp (3 Ea.)
(For Detailed Grading, See Sht. 2B-6)
- ⑥ Remove Extg. Mailbox Upon Installation of the Proposed Mailbox Cluster
- ⑦ Construct Driveway
A - Sta. 37+01.83, 13.50'Rt. - Sta. 37+37.83, 13.50'Rt.
B - Sta. 37+74.45, 20.50'Lt. - Sta. 38+14.00, 20.50'Lt.
C - Sta. 38+14.00, 20.50'Lt. - Sta. 38+48.00, 20.50'Lt.
D - Sta. 38+14.00, 20.50'Lt. - Sta. 38+48.00, 20.50'Lt.
(For Details, See Sht. 2B)
- ⑧ Prop. Light Fixture
(Refer to Sheets IL-2 Thru IL-6)
- ⑨ Adjust Water Valve to Grade (Minor) (2 Ea.)
- ⑩ Remove Extg. Pavement, Curb, and Sidewalk
- ⑪ STA: 33+33.45
Begin Construction Centerline at STA 2+00.00
- ⑫ Install Permanent Lawn Seeding (±2,265 SF)
- ⑬ Water Meter Relocation, By City Forces
- ⑭ Install Fire Hydrant
STA: 36+30.63, 21.50' Rt.
Back of Walk Elevation = 182.73
(For Details, See Sht. 2B-5)
- ⑮ STA: 38+21.42, 37.34'Rt.
Install Permanent Street Tree 'Kwanzan Cherry Plum' [Prunus 'Kwanza'] (3 Ea.)
(For Details, See Sht. 2B)

STORM CONSTRUCTION NOTES

- ① Install CG-48 Manhole Inlet (1 Ea.)
(For Details, See Sht. 2B-4)
- ② Connect to Extg. Structure (1 Ea.)
(For Details, See Sht. 2B-4)
- ③ Adjust Manhole Rim to Grade (Major) (3 Ea.)
- ④ Install CG-48 Inlet (2 Ea.)
(For Details, See Sht. 2B-4)
- ⑤ Construct Water Quality Facility
See Sheet 2G for Details

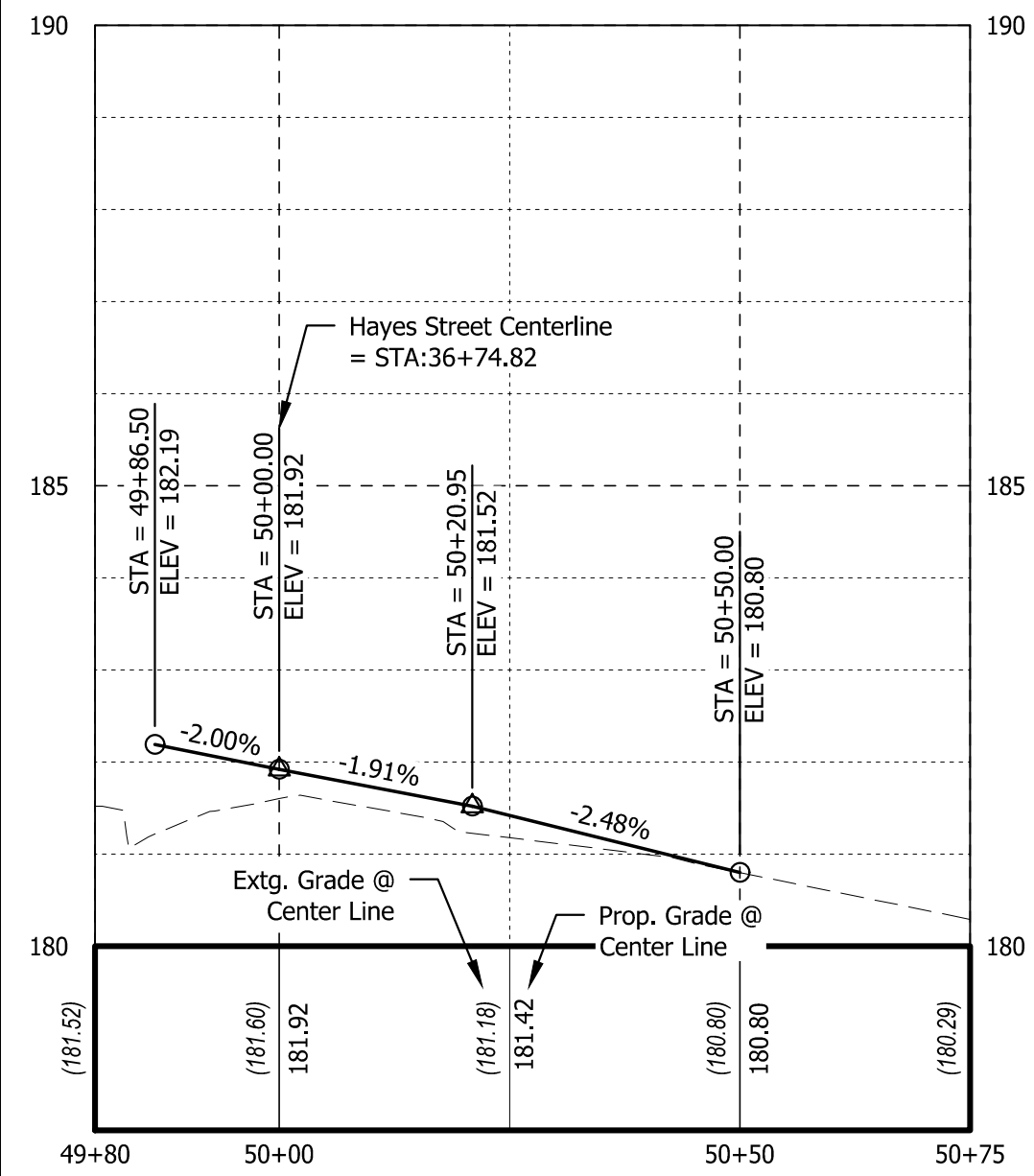

Hall St Connection Profile

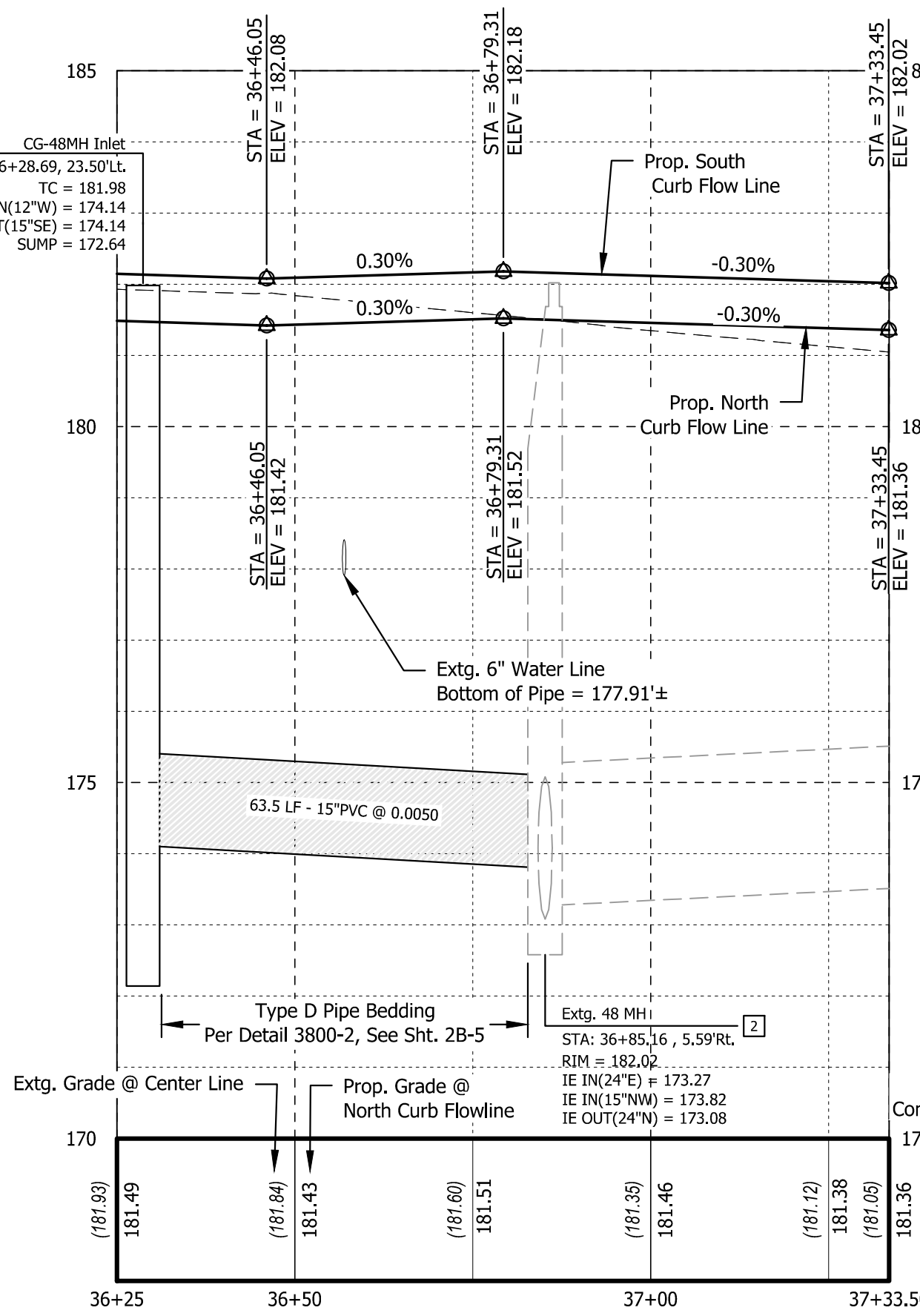

Hayes Street Profile
 Horz: 1"=20', Vert: 1"=2'

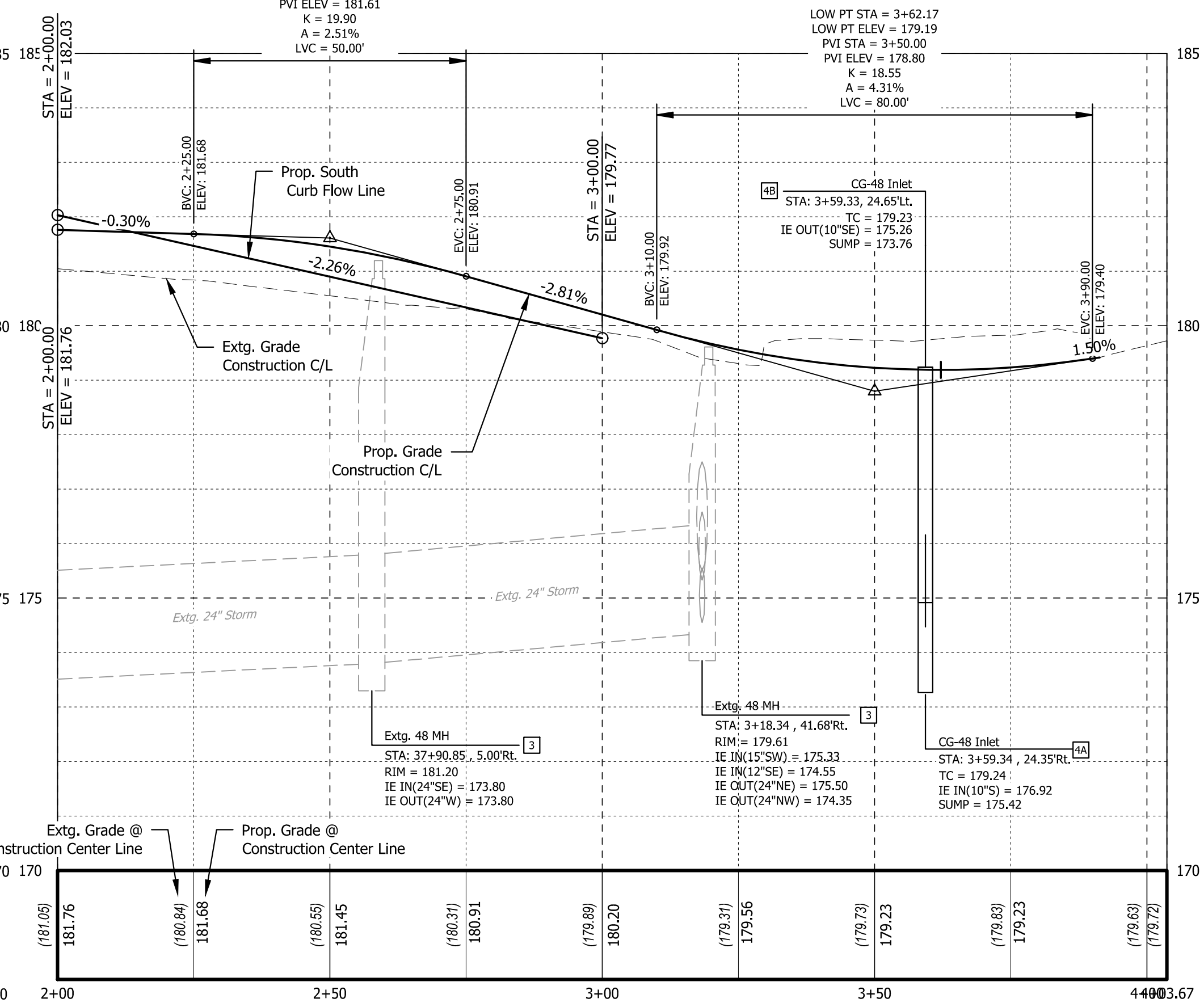

Hayes Street Construction Profile
 Horz: 1"=20', Vert: 1"=2'

Earthworks
 Excavation 651.9 CY
 Embankment 35.8 CY

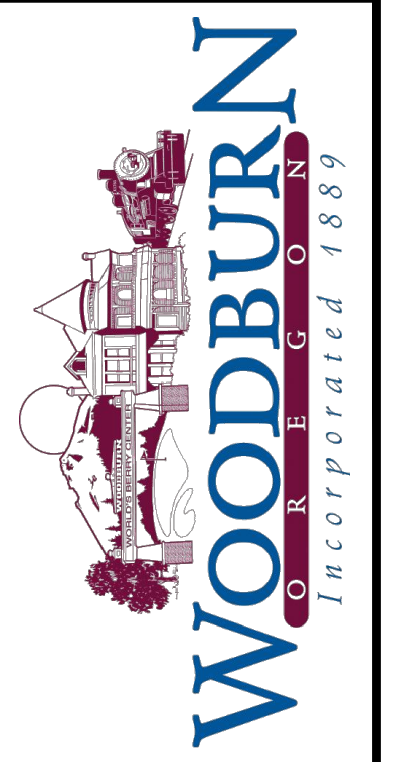
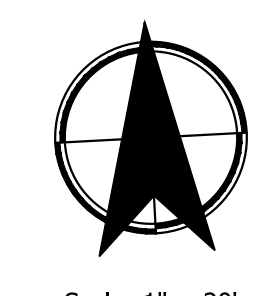

KITTELSON & ASSOCIATES
 851 SW 6TH AVENUE, SUITE 600
 PORTLAND, OR 97204
 P 503.228.5230 F 503.273.8169

NO.	REVISION	DATE	BY	APP'D.
01	ISSUE FOR CONSTRUCTION	05/25/22	FSW	APP'D.

Submission Date: 03/07/2022
 Drawn: JCB/RMM, Designed: NRS/JBK, Checked: FSW

PROJECT NO. 2015-001-20

W. Hayes Street Improvements
 Cascade Avenue to Settlemier Avenue
 HAYES PLAN AND PROFILE

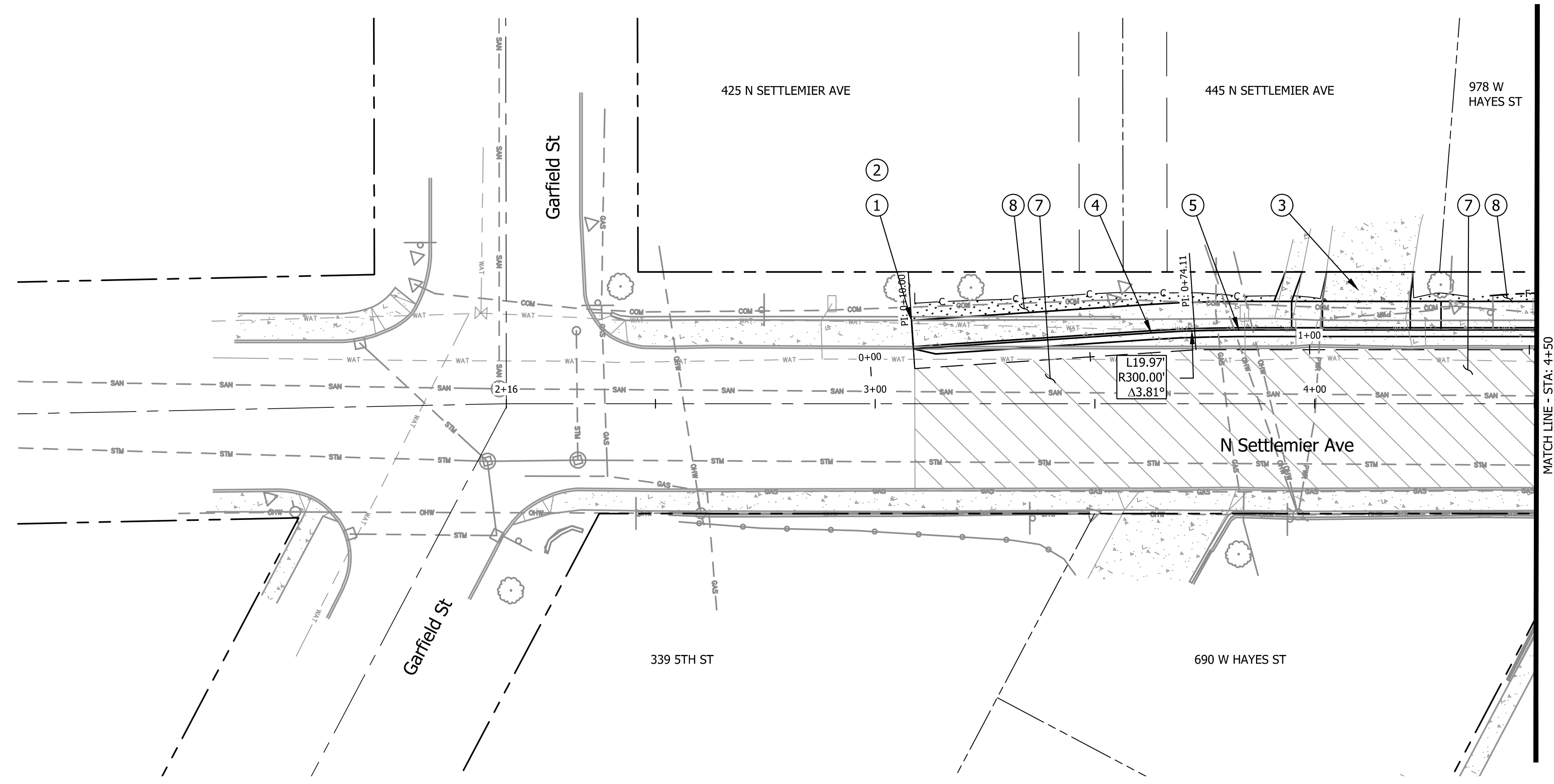

CONSTRUCTION NOTES

- ① Construct Std. Curb & Gutter, & Sidewalk
Match Existing
(For Details, See Sht. 2B)
- ② Sawcut & Remove Extg. Pavement, Curb & Gutter, & Sidewalk
- ③ Construct Driveway
Sta. 3+94.77, 16.78'Lt - Sta. 3+28.77, 16.79'Lt
(For Details, See Sht. 2B)
- ④ Curb Point of Curvature
STA: 3+62.85, 16.11'Lt.
- ⑤ Curb Point of Tangency
STA: 3+82.81, 16.78'Lt.
- ⑥ Curb Point of Tangency
STA: 3+82.81, 16.78'Lt.
- ⑦ 2" Grind and Inlay
Per Typical Sections, See Sheet 2A
- ⑧ Install Permanent Lawn Seeding (±285 SF)

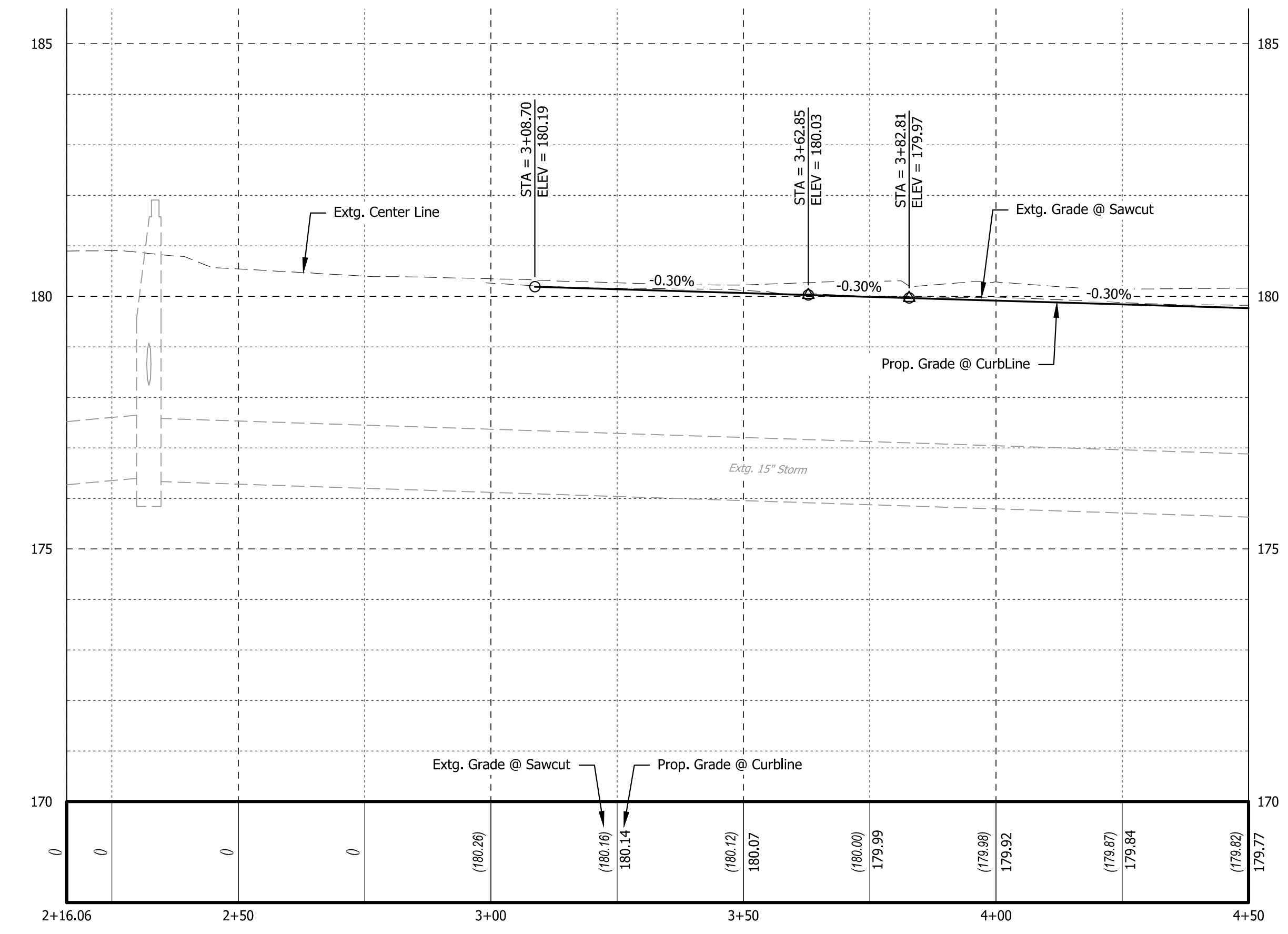

Settlemier Ave Profile
Horz: 1"=20', Vert: 1"=2'

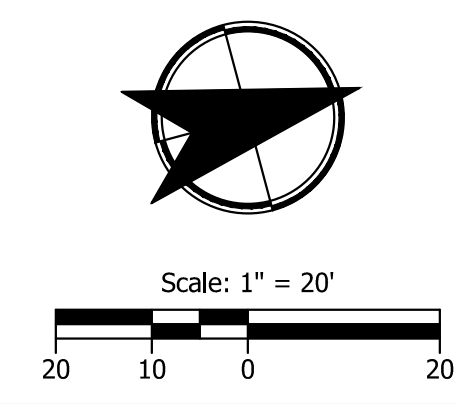

Earthworks
Excavation 91.1 CY
Embankment 0.0 CY

REGISTERED PROFESSIONAL ENGINEER
74207PE
Digitally Signed May 27 2022 11:41 AM
OREGON
JULY 8 2008
FRED S. WISMER JR.
EXPIRES: 06/30/24
FINAL ELECTRONIC DOCUMENT
AVAILABLE UPON REQUEST

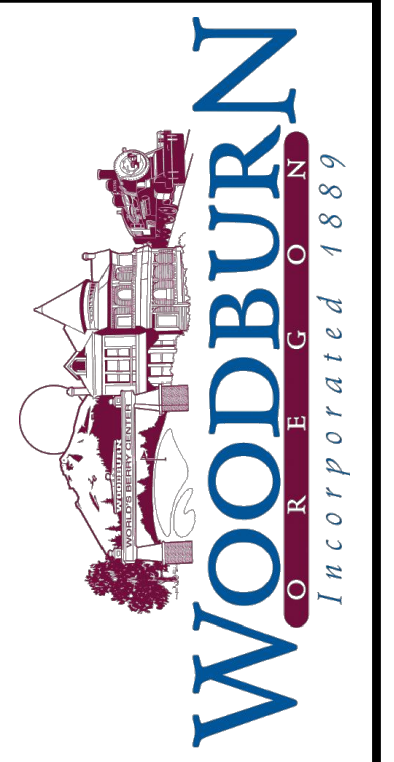

KITTELSON & ASSOCIATES
851 SW 6TH AVENUE, SUITE 600
PORTLAND, OR 97204
P 503.228.5230 F 503.273.8169

#	DATE	REVISION	APP'D
0	05/25/22	ISSUE FOR CONSTRUCTION	FSW

Submission Date:
03/07/2022

Drawn: JCB/RMM
Designed: NRS/JBK
Checked: FSW

PROJECT NO.
2015-001-20

W. Hayes Street Improvements
Cascade Avenue to Settlemier Avenue

SETTLEMIER PLAN AND PROFILE

SHEET NO.
10

Plot Stamp: 5/27/2022 11:31:35 AM - Fred Wismer
File: H:\24\24512 - W. Hayes Street\design\CD\CD-Street\Plans-24512.dwg

NO.	DATE	REVISION	APP'D.
0	05/25/22	ISSUE FOR CONSTRUCTION	FSW

Drawn:	Designed:	Checked:
JCB/RMM	NRS/JBK	FSW

PROJECT NO.
2015-001-20

W. Hayes Street Improvements
Cascade Avenue to Settlemier Avenue

SETTLEMIER PLAN AND PROFILE

SHEET NO.
11

CONSTRUCTION NOTES

- ① Construct Std. Curb & Gutter, & Sidewalk (For Details, See Sht. 2B)
- ② Remove Extg. Pavement, Curb & Gutter, & Sidewalk
- ③ Sawcut & Remove Extg. Pavement, Curb & Gutter, & Sidewalk
- ④ Construct Parallel Sidewalk Ramp (6 Ea.) (For Detailed Grading, See Sht. 2B)
- ⑤ Construct Standard Curb (For Detailed Grading, See Sht. 2B)
- ⑥ Construct Doweled Median Island (For Details, See Sht. 2B-2)
- ⑦ Construct Driveway Sta. 6+94.56, 15.18'Lt - Sta. 7+38.21, 14.18'Lt (For Details, See Sht. 2B)
- ⑧ Install 6" Reinforced Concrete Section Over 4" of 1"-0 Minus Aggregate
- ⑨ 2" Grind and Inlay Per Typical Sections, See Sheet 2A
- ⑩ Install Permanent Lawn Seeding (±1,140 SF)

STORM CONSTRUCTION NOTES

- ① Install CG-48 Inlet (Ea. 1) (For Details, See Sht. 2B-4)
- ② Install CG-2 Inlet (Ea. 3) (For Details, See Sht. 2B-3)
- ③ Connect to Extg. Structure (Ea. 1) (For Details, See Sht. 2B-4)
- ④ N Settlemier Ave Sta. 5+37.12, 13.85' Rt. Tee into Extg. 15" Stormwater Pipe (Ea. 1) (For Details, See Sht. 2B-4)
- ⑤ W Hayes St. Sta. 39+05.92, 6.95' Rt. Tee into Extg. 24" Stormwater Pipe (Ea. 1) (For Details, See Sht. 2B-4)

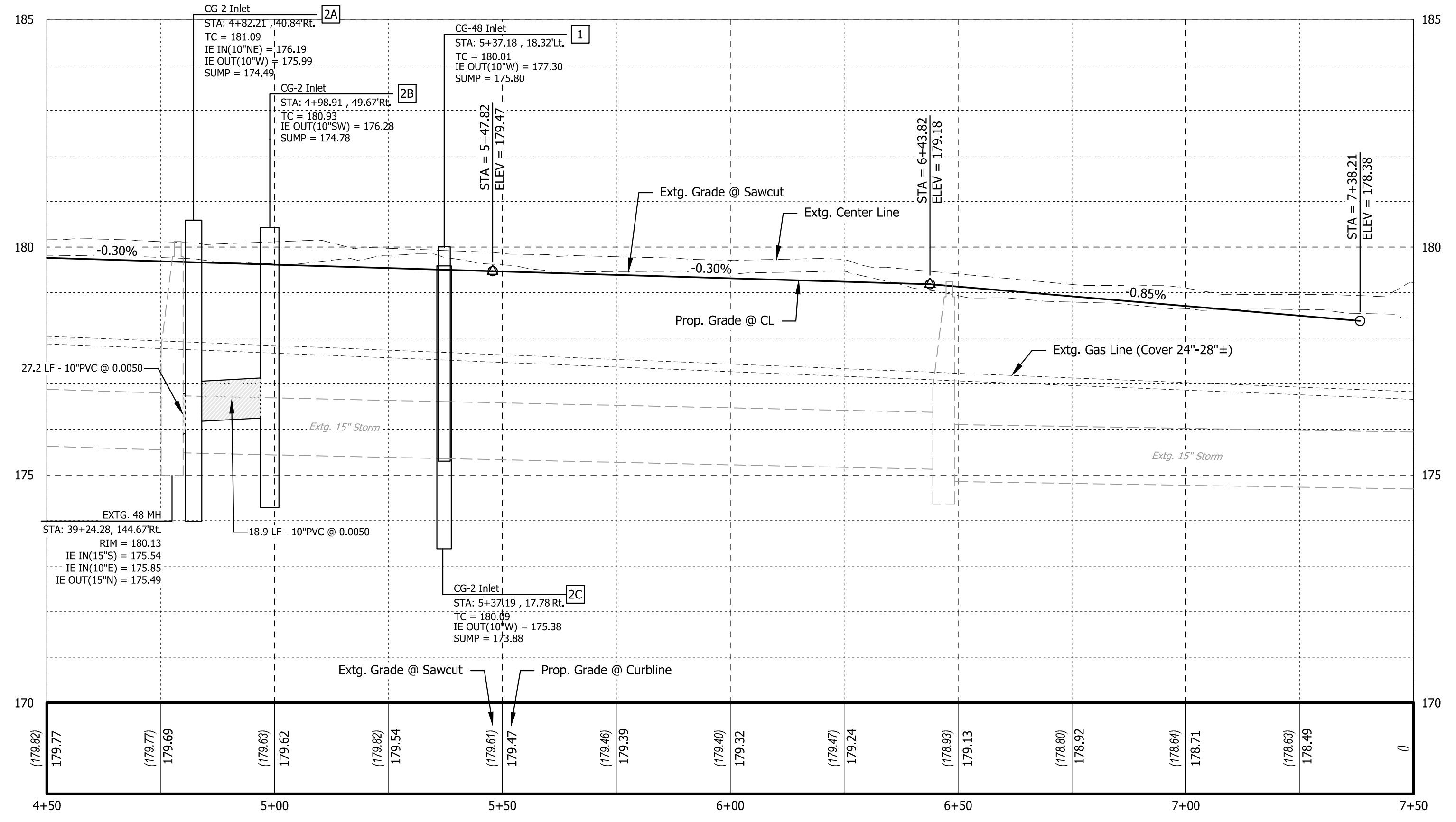
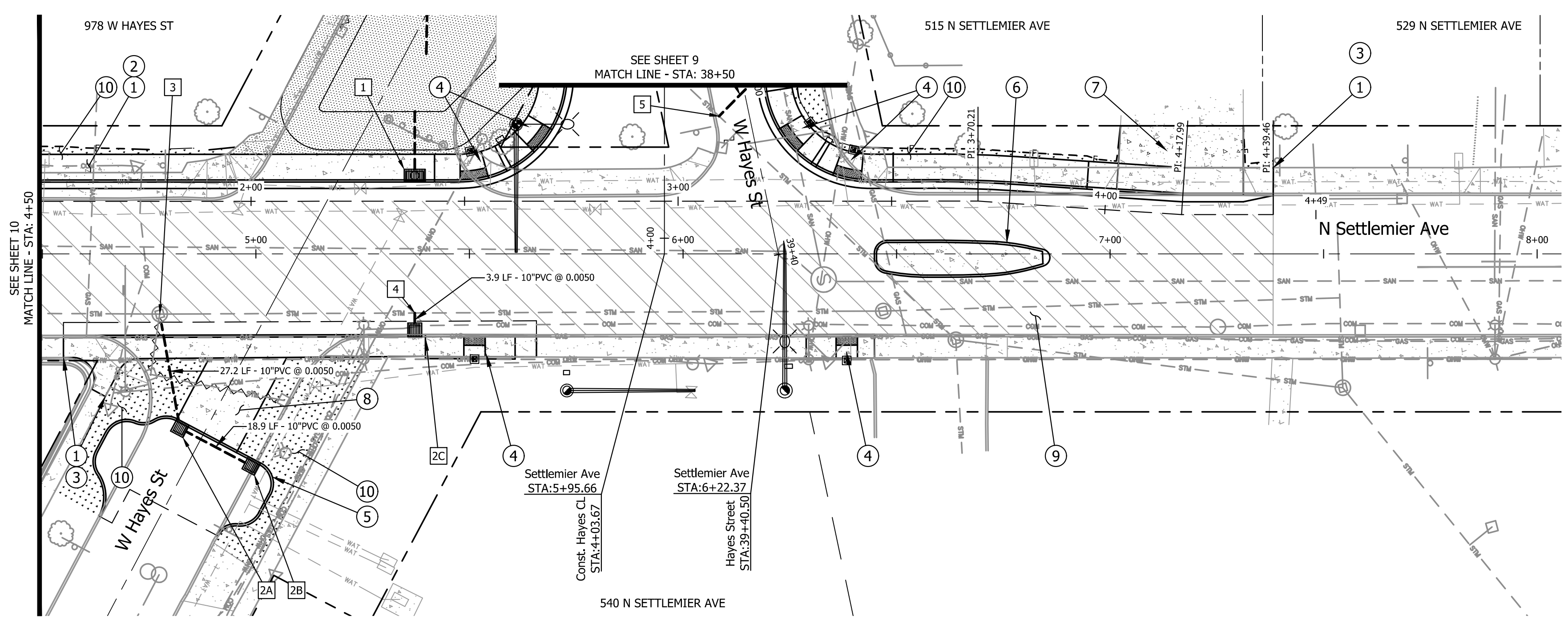

Settlemier Ave Profile
Horz: 1"=20', Vert: 1"=2'

Earthworks
Excavation
329.7 CY
Embankment
6.6 CY

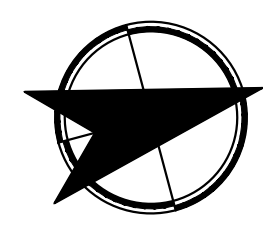

Scale: 1" = 20'

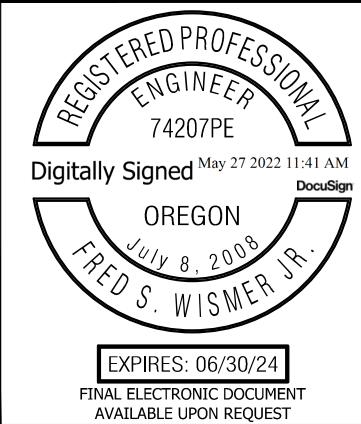

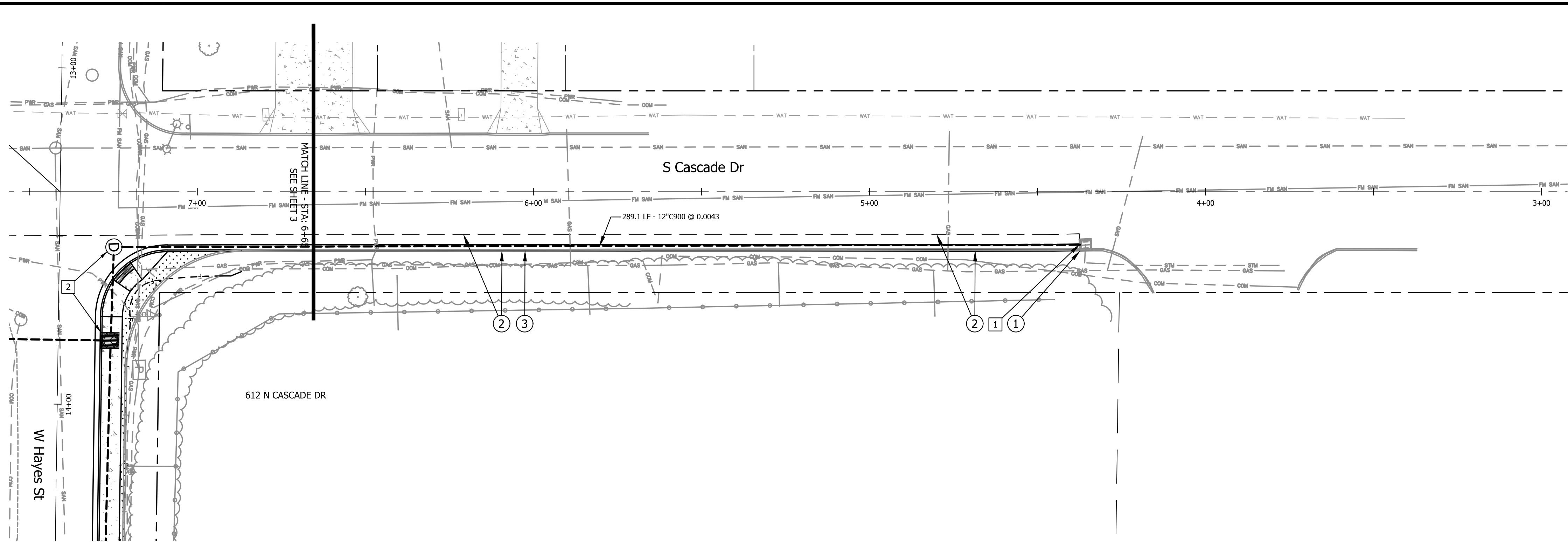

CONSTRUCTION NOTES

- ① Cascade Dr Sta: 4+37.47, 17.00' Lt.
End Construct Std. Curb & Gutter, Match Extg.
For Details, See Sht. 2B)
- ② Sawcut & Remove Extg. Pavement, Curb & Gutter
- ③ Construct Std. Curb & Gutter, & Sidewalk
(For Details, See Sht. 2B)

STORM CONSTRUCTION NOTES

- ① Connect to Extg. Structure (Ea. 1)
(For Details, See Sht. 2B-4)
- ② Proposed Storm Structure
See Sheet 3 for Details

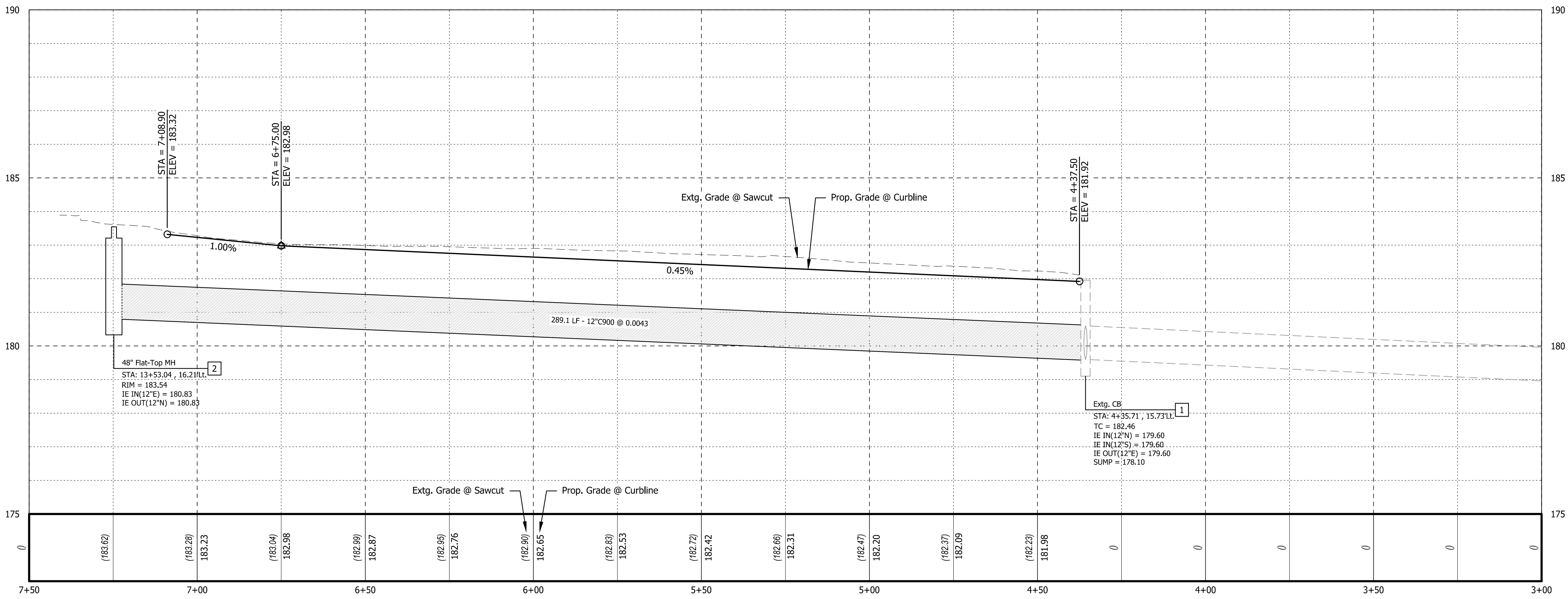

S Cascade Profile
Horz: 1"=20', Vert: 1"=2'

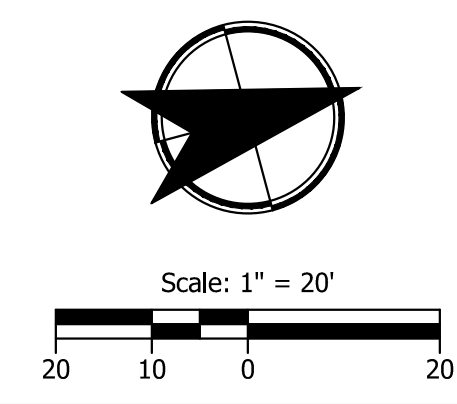

Earthworks	Excavation	86 CY
Embankment	0	

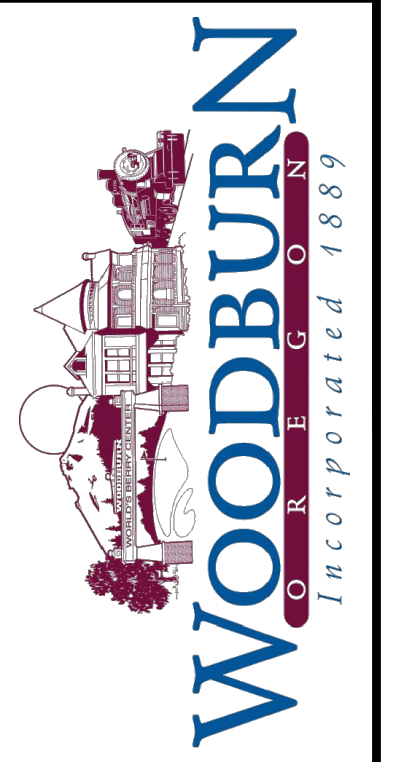
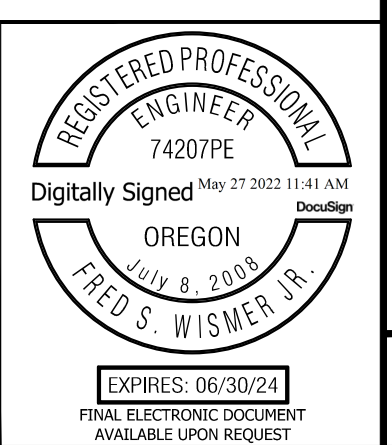

KITTELSON & ASSOCIATES
851 SW 6TH AVENUE, SUITE 600
PORTLAND, OR 97204
P 503.228.5230 F 503.273.8169

#	DATE	REVISION	FSW	APP'D
0	05/25/22	ISSUE FOR CONSTRUCTION		

Submission Date: 03/07/2022
Drawn: JCB/RMM, Designed: NRS/JBK, Checked: FSW
PROJECT NO. 2015-001-20

W. Hayes Street Improvements
Cascade Avenue to Settlemier Avenue
CASCADE PLAN AND PROFILE

SHEET NO. 12

Plot Stamp: 5/27/2022 11:33:03 AM - Fred Wismer
 File: H:\24\24512 - W. Hayes Street\design\CD\CD-Signing and Striping-24512.dwg

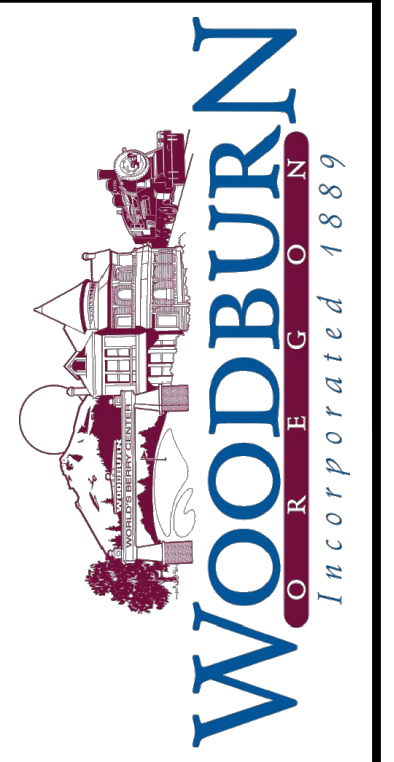
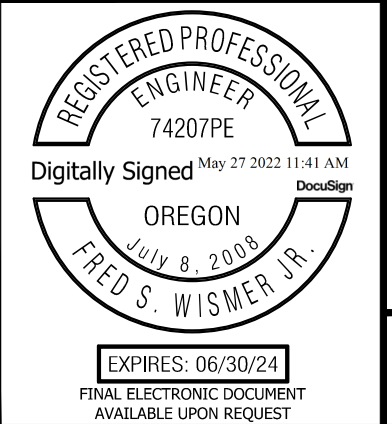
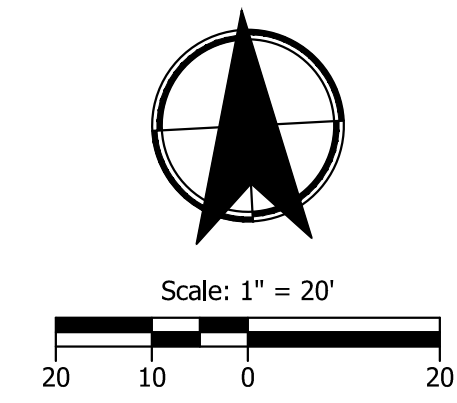
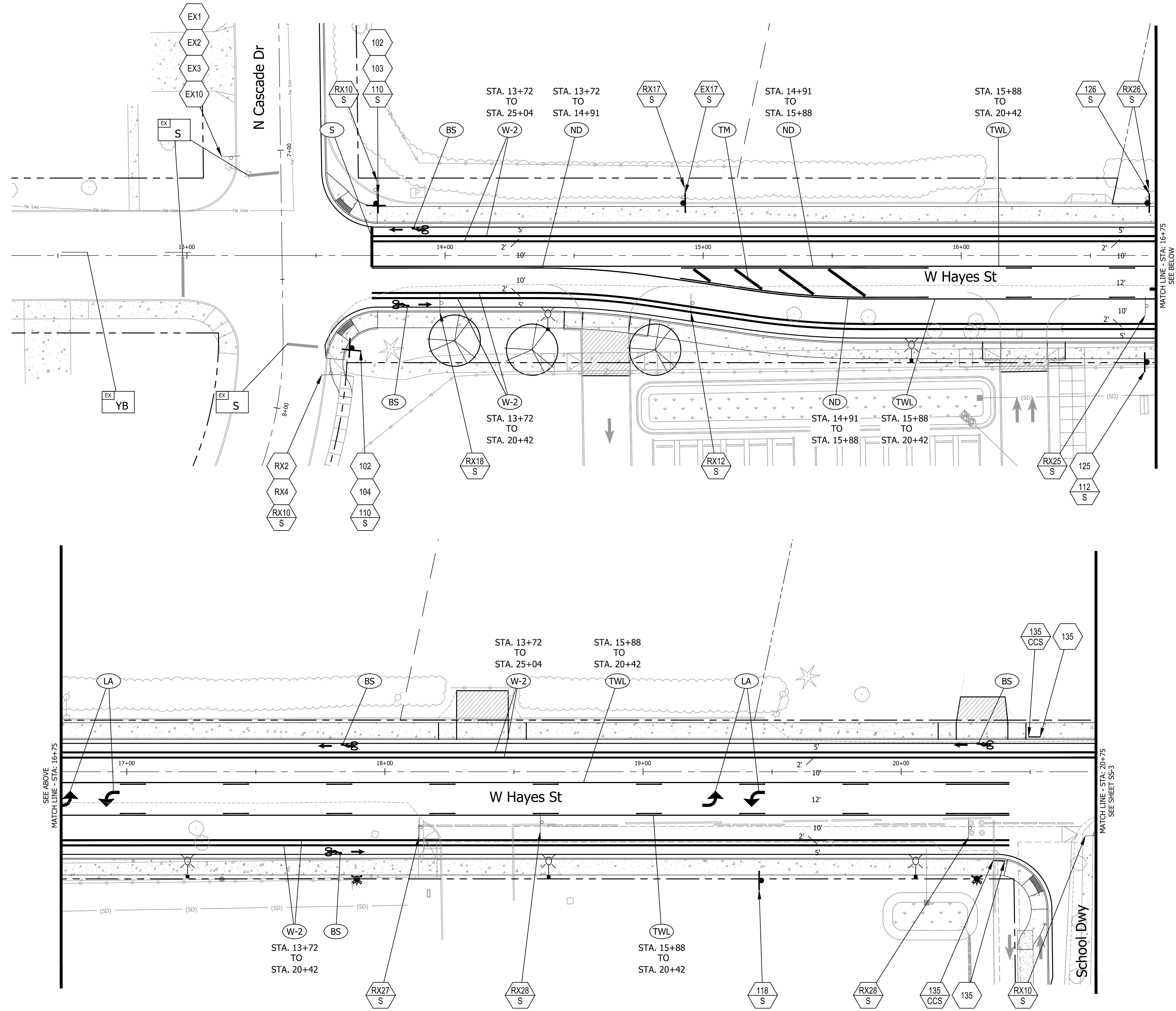

KITTELSON & ASSOCIATES
 851 SW 6TH AVENUE, SUITE 600
 PORTLAND, OR 97204
 P 503.228.5230 F 503.273.8169

#	DATE	REVISION	APP'D
0	05/25/22	ISSUE FOR CONSTRUCTION	FSW

Submission Date: 03/07/2022
 Drawn: JCB/RMM
 Designed: NRS/JBK
 Checked: FSW

PROJECT NO.
2015-001-20
W. Hayes Street Improvements
 Cascade Avenue to Settlemier Avenue
 SIGNING AND STRIPING PLAN
 SHEET NO.
SS-2

Plot Stamp: 5/27/2022 11:33:16 AM - Fred Wismer
 File: H:\24\24512 - W. Hayes Street\design\CD\CD-Signing and Striping-24512.dwg

Install ten (10) yellow bi-directional raised pavement markers on top of the curb as shown

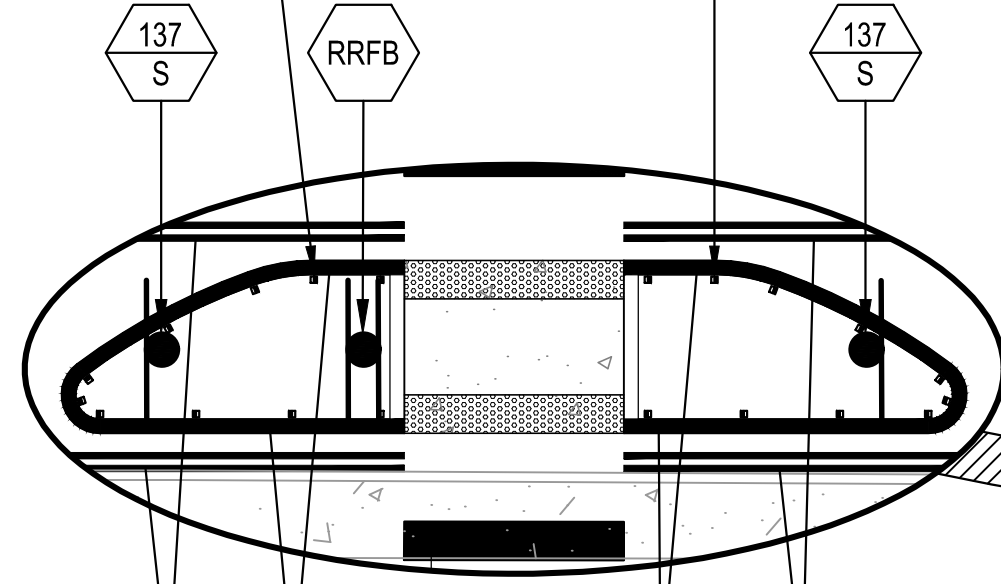

Median Detail
 SCALE: 1" = 10'

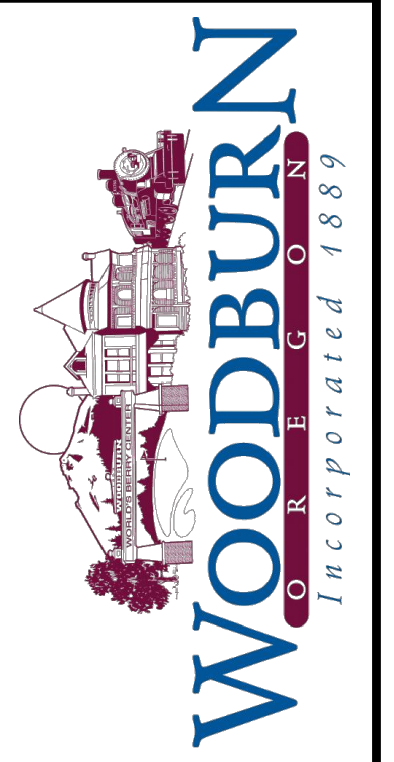
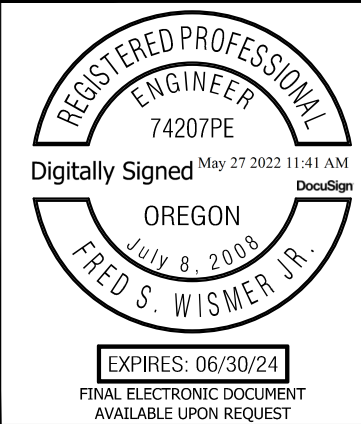
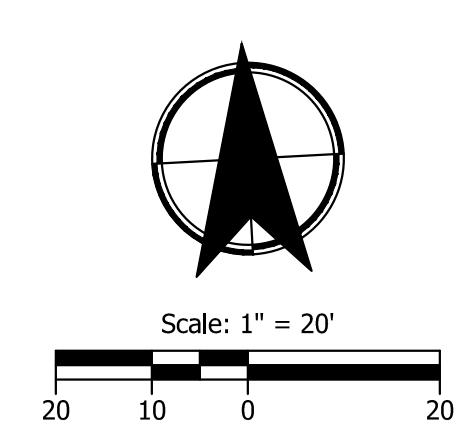
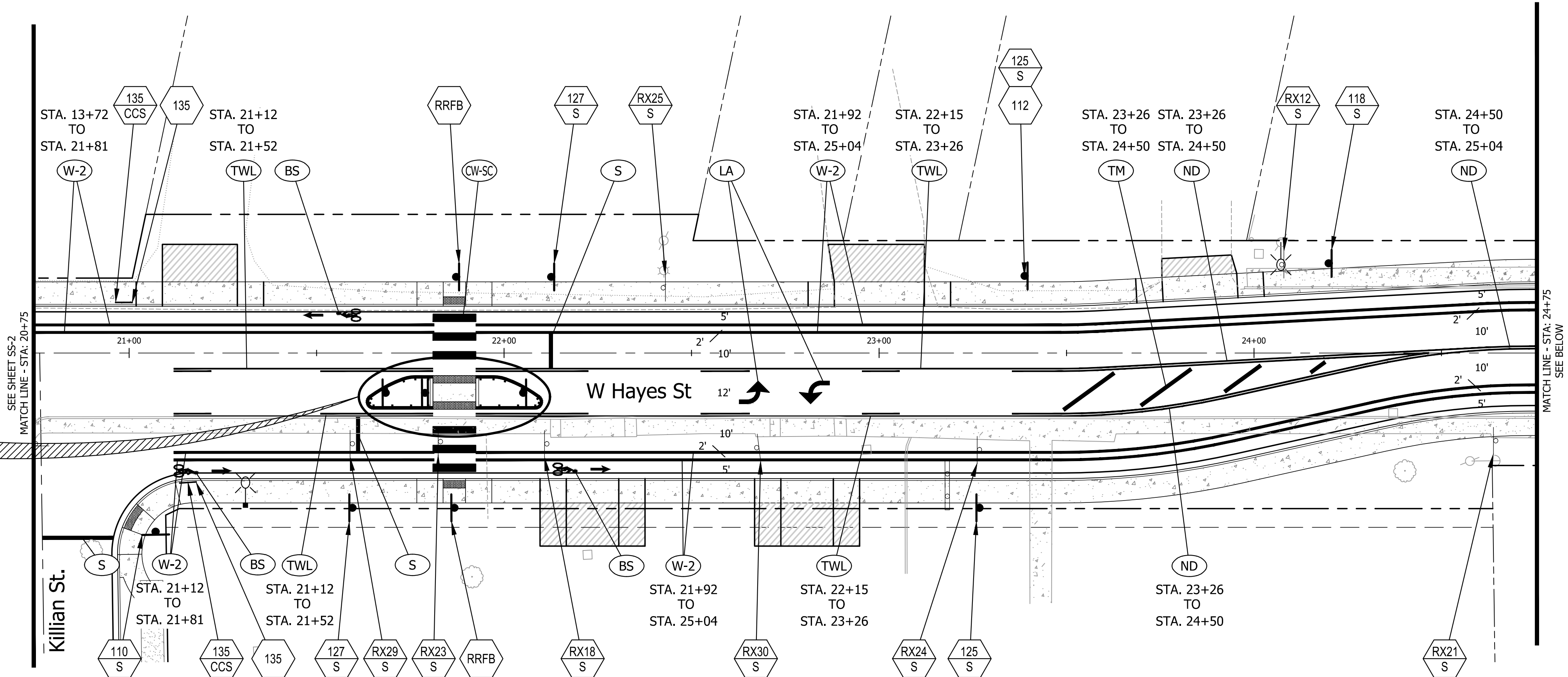
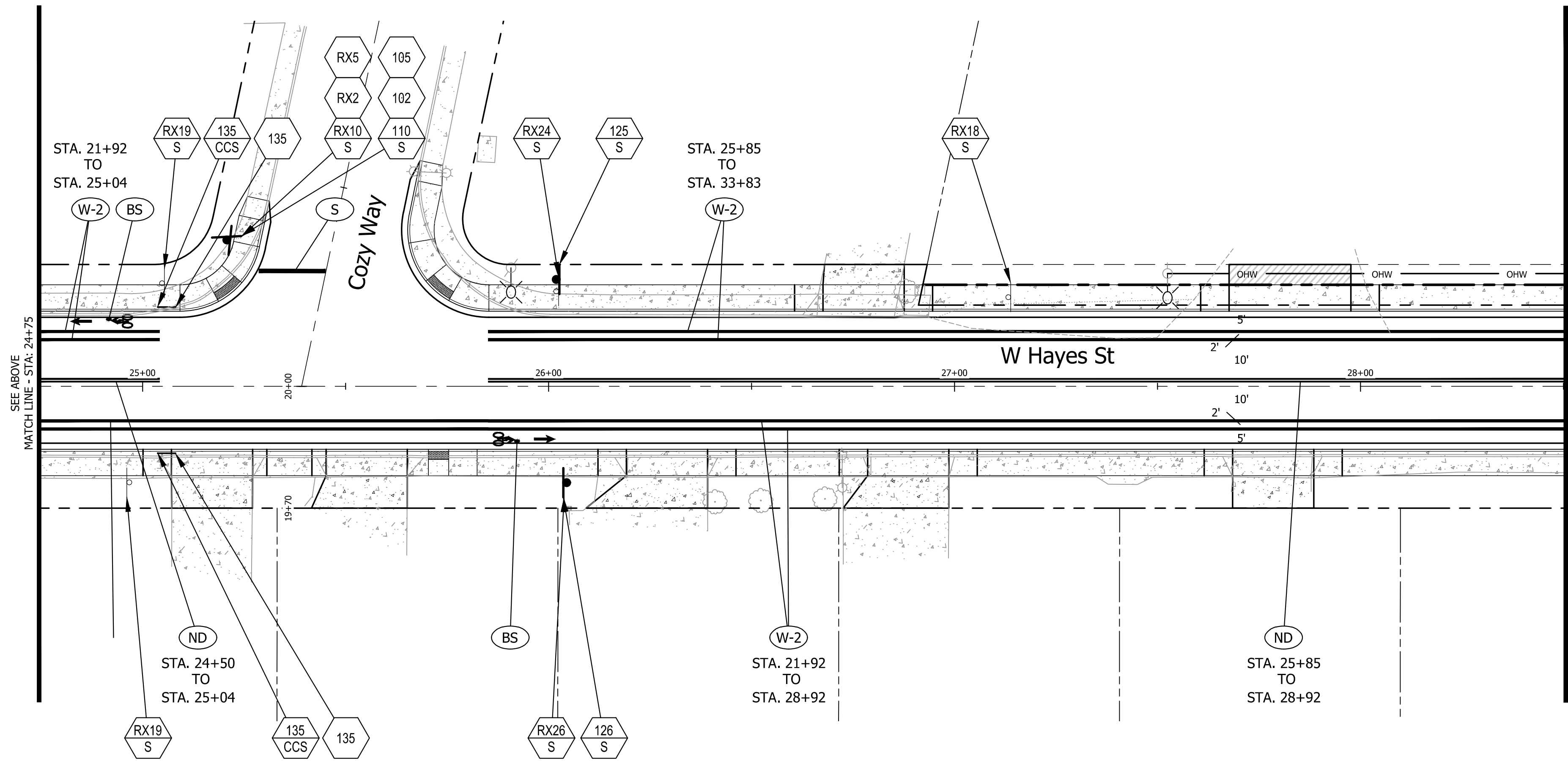

KITTELSON & ASSOCIATES
 851 SW 6TH AVENUE, SUITE 600
 PORTLAND, OR 97204
 P 503.228.5230 F 503.273.8169

NO.	DATE	REVISION	APP'D
0	05/25/22	ISSUE FOR CONSTRUCTION	FSW

Submission Date: 03/07/2022
 Drawn: JCB/RMM
 Designed: NRS/JBK
 Checked: FSW

PROJECT NO. 2015-001-20
W. Hayes Street Improvements
 Cascade Avenue to Settlemier Avenue
 SIGNING AND STRIPING PLAN
 SHEET NO. SS-3

Plot Stamp: 5/27/2022 11:33:27 AM - Fred Wismer
 File: H:\24\24512 - W. Hayes Street\design\CD\CD-Signing and Striping-24512.dwg

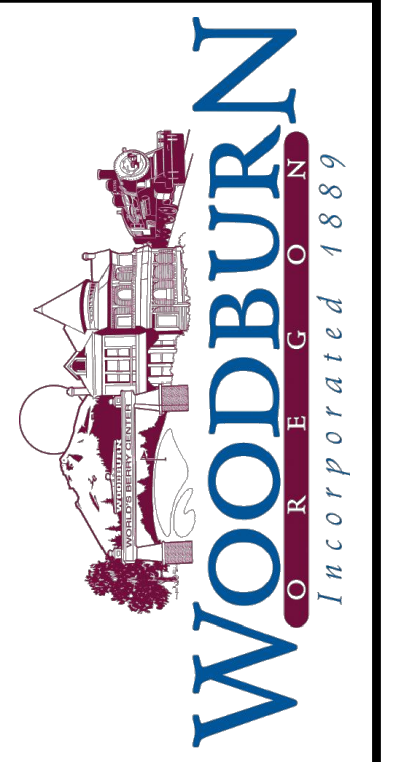
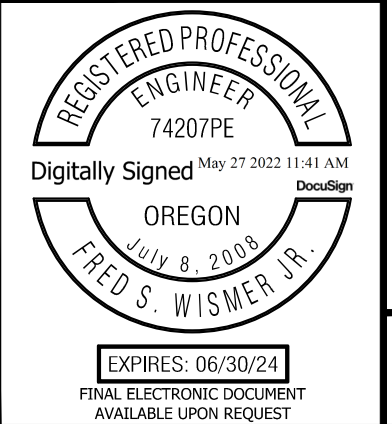
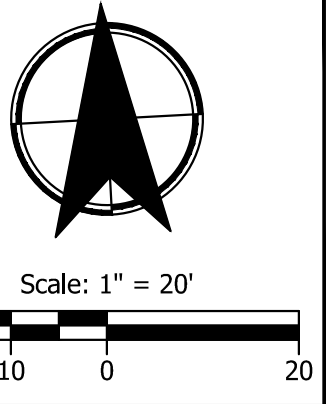
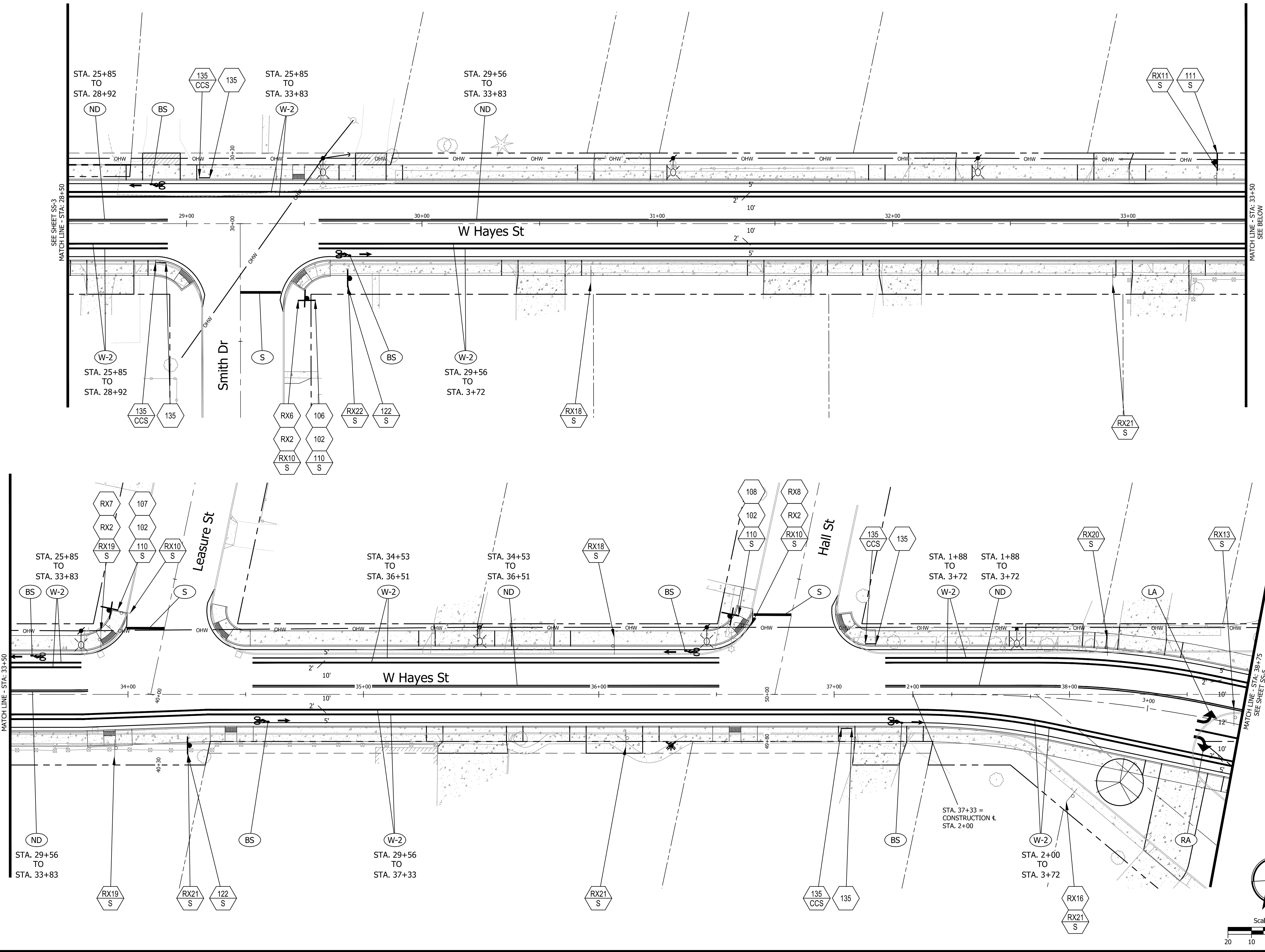

KITTELSON & ASSOCIATES
 851 SW 6TH AVENUE, SUITE 600
 PORTLAND, OR 97204
 P 503.228.5230 F 503.273.8169

NO.	DATE	REVISION	APP'D.
0	05/25/22	ISSUE FOR CONSTRUCTION	FSW
		REVISION	

Submission Date: 03/07/2022
 Drawn: JCB/RMM
 Designed: NRS/JBK
 Checked: FSW

PROJECT NO. 2015-001-20
W. Hayes Street Improvements
 Cascade Avenue to Settlemier Avenue
 SIGNING AND STRIPING PLAN
 SHEET NO. SS-4

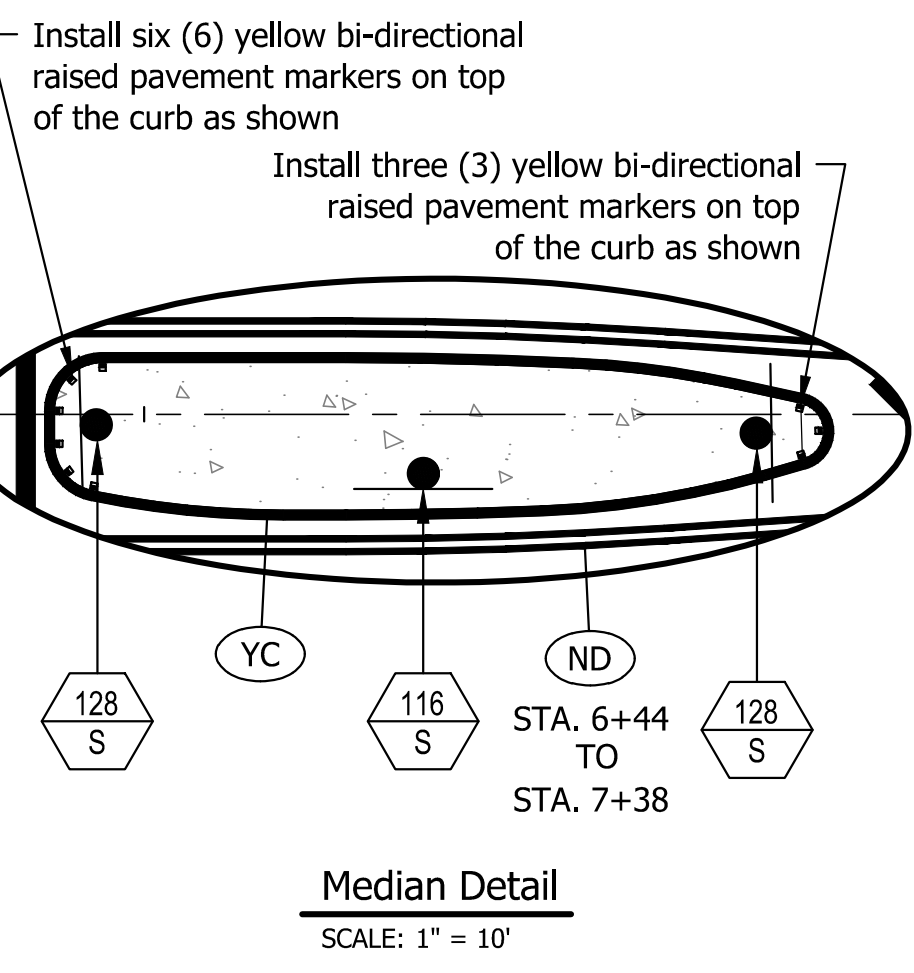
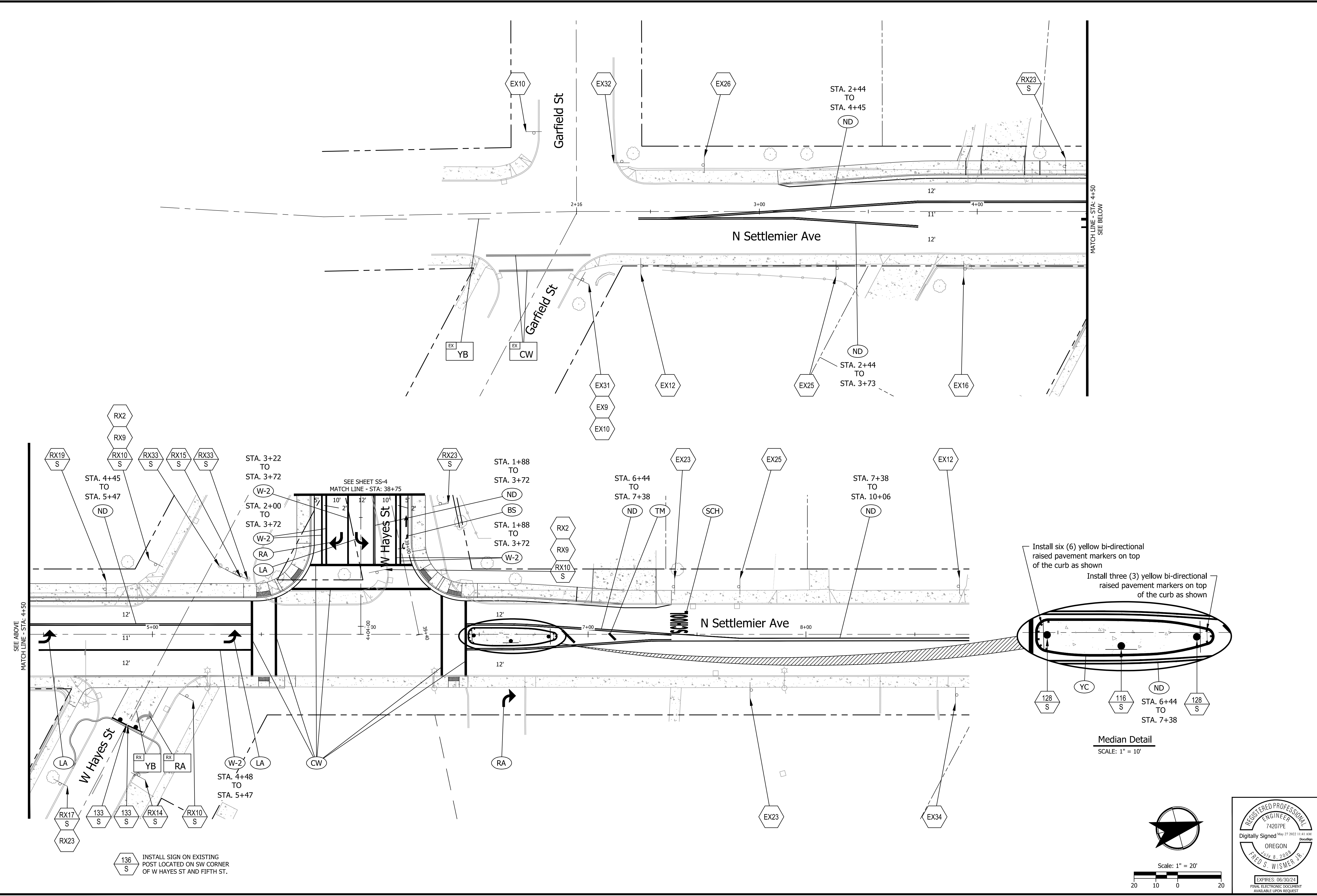

136 S INSTALL SIGN ON EXISTING POST LOCATED ON SW CORNER OF W HAYES ST AND FIFTH ST.

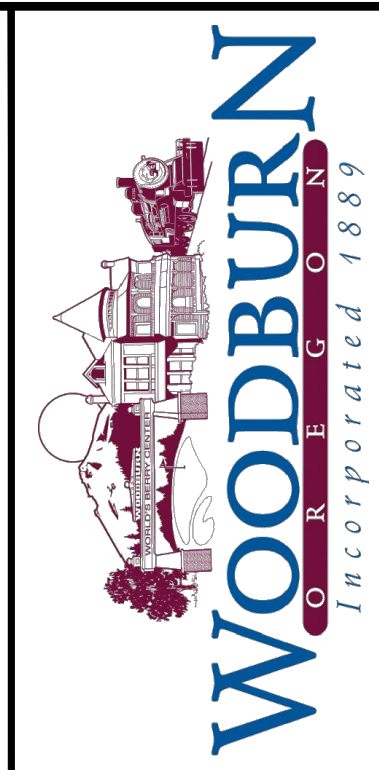
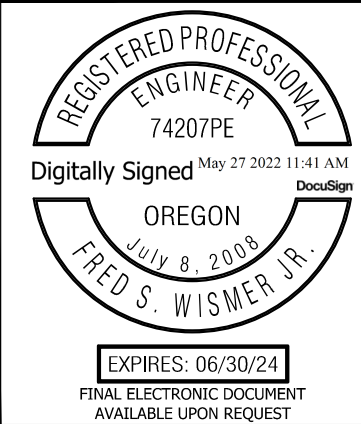
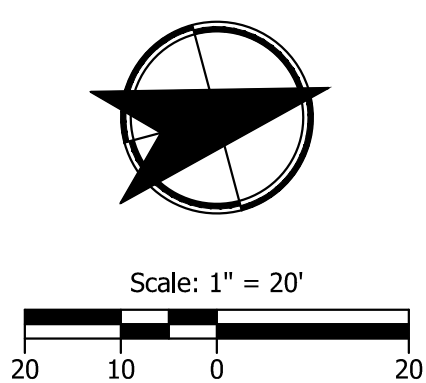

KITTELSON & ASSOCIATES
 851 SW 6TH AVENUE, SUITE 600
 PORTLAND, OR 97204
 P 503.228.5230 F 503.273.8169

#	DATE	REVISION	APP'D
0	05/25/22	ISSUE FOR CONSTRUCTION	FSW

Submission Date: 03/07/2022
 Drawn: JCB/RMM
 Designed: NRS/JBK
 Checked: FSW

PROJECT NO.
 2015-001-20

W. Hayes Street Improvements
 Cascade Avenue to Settlemier Avenue
 SIGNING AND STRIPING PLAN

SHEET NO.
 SS-5

EXISTING SIGNS

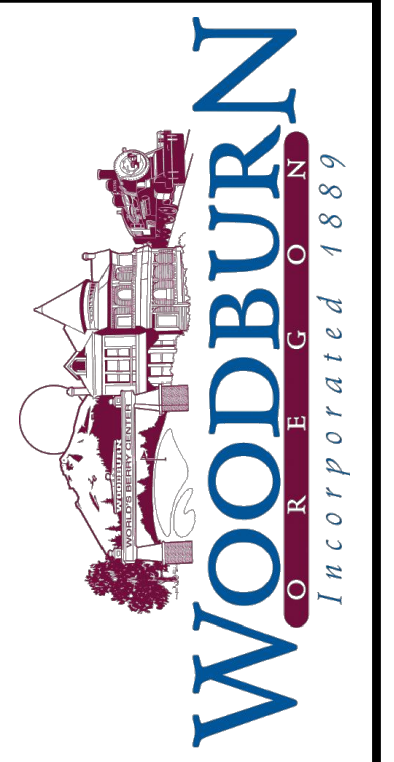
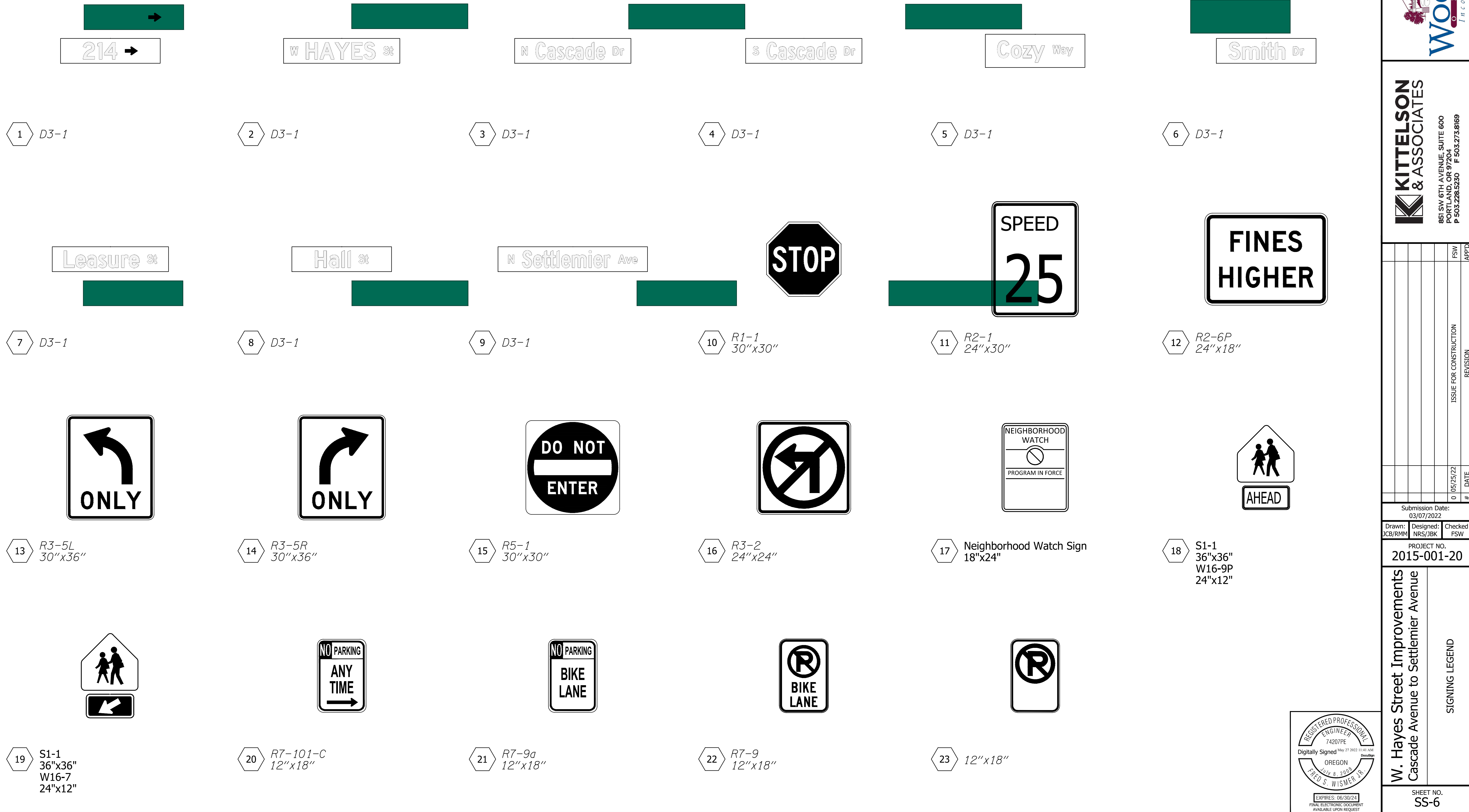

KITTELSON & ASSOCIATES
 851 SW 6TH AVENUE, SUITE 600
 PORTLAND, OR 97204
 P 503.228.5230 F 503.273.8169

NO.	DATE	REVISION	APP'D
0	05/25/22	ISSUE FOR CONSTRUCTION	FSW

Submission Date: 03/07/2022
 Drawn: JCB/RMM Designed: NRS/JBK Checked: FSW

PROJECT NO. 2015-001-20
 W. Hayes Street Improvements
 Cascade Avenue to Settlemier Avenue
 SHEET NO. SS-6
 SIGNING LEGEND

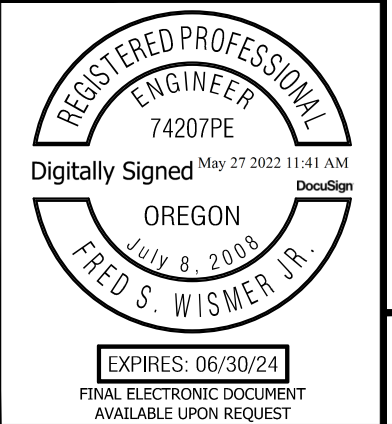

Plot Stamp: 5/25/2022 4:01:39 PM - Fred Wismer
 File: H:\24\24512 - W. Hayes Street\design\CD\CD-Signing and Striping-24512.dwg

EXISTING SIGNS

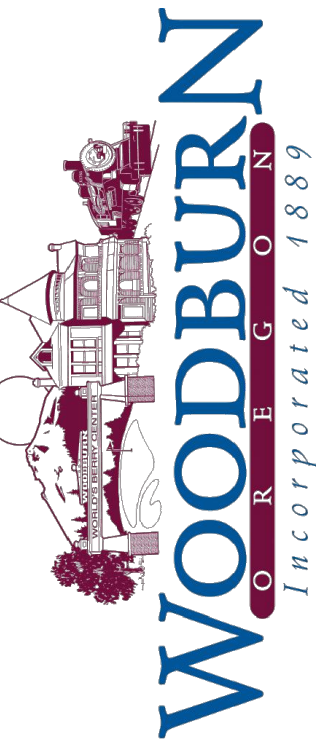
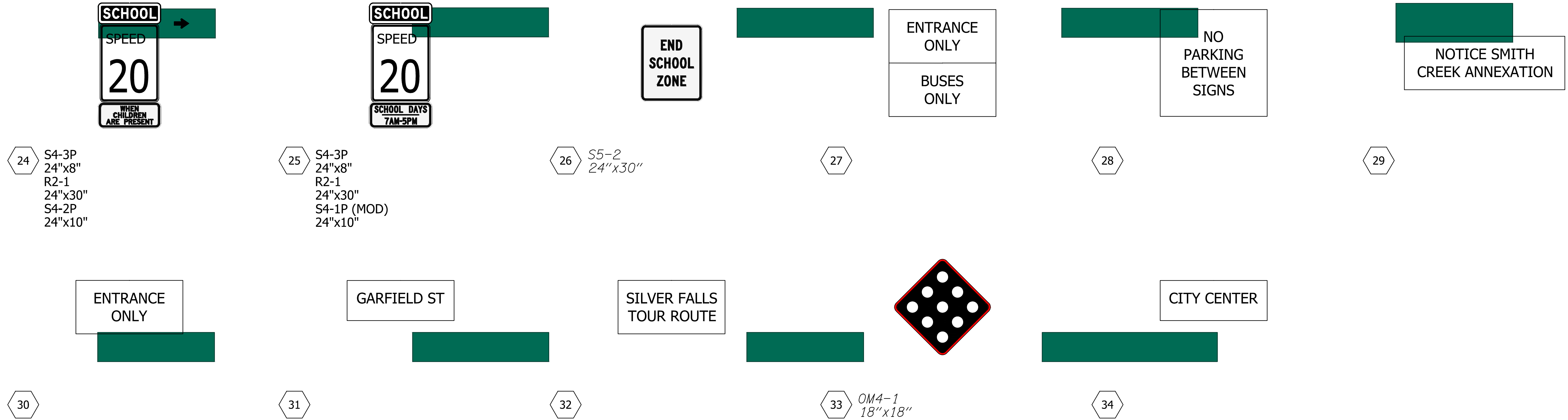

KITTELSON & ASSOCIATES
851 SW 6TH AVENUE, SUITE 600
PORTLAND, OR 97204
P 503.228.5230 F 503.273.8169

#	DATE	REVISION	APP'D
0	05/25/22	ISSUE FOR CONSTRUCTION	FSW

Submission Date:
03/07/2022

Drawn: JCB/RMM
Designed: NRS/JBK
Checked: FSW

PROJECT NO.
2015-001-20

W. Hayes Street Improvements
Cascade Avenue to Settlemier Avenue

STIGNING LEGEND

SHEET NO.
SS-7

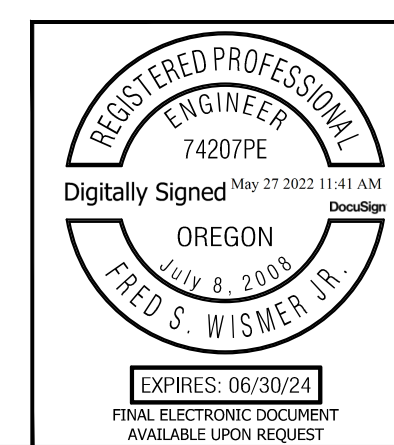

Plot Stamp: 5/25/2022 4:01:41 PM - Fred Wismer
File: H:\24\24512 - W. Hayes Street\design\CD\CD-Signing and Striping-24512.dwg

PROPOSED SIGNS

W Hayes St

N Cascade Dr

S Cascade Dr

Cozy Way

Smith Dr

Leasure St

102 D3-1
42"x12"
6 Required
2-Sided

103 D3-1
42"x12"
1 Required
2-Sided

104 D3-1
42"x12"
1 Required
2-Sided

105 D3-1
36"x12"
1 Required
2-Sided

106 D3-1
36"x12"
1 Required
2-Sided

107 D3-1
42"x12"
1 Required
2-Sided

Hall St

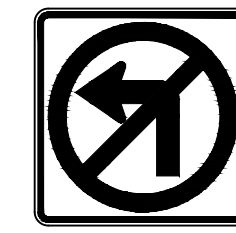
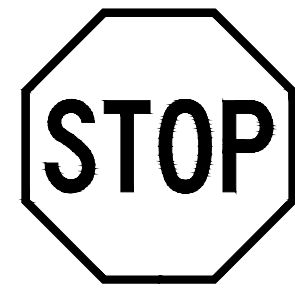

108 D3-1
36"x12"
1 Required
2-Sided

110 R1-1
30"x30"
7 Required

111 R2-1
24"x30"
1 Required

112 R2-6P
24"x18"
2 Required

116 R3-2
24"x24"
1 Required

118 S1-1
36"x36"
W16-9P
24"x12"
2 Required

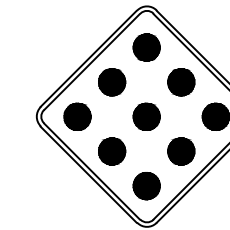
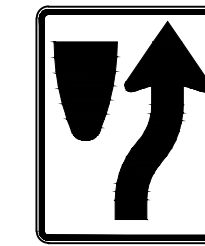
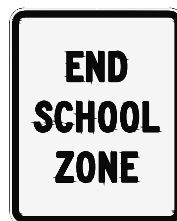

122 R7-9
12"x18"
2 Required

125 OS5-5
24"x36"
OS4-8
24"x10"
4 Required

126 S5-2
24"x30"
2 Required

127 R1-5b
36"x36"
2 Required

128 R4-7
24"x30"
2 Required

133 OM4-1
18"x18"
2 Required



135 OR22-7
24"x18"
20 Required

136 W14-1
24"x24"
1 Required

137 OM3-L
12"x36"
2 Required



KITTELSON & ASSOCIATES
851 SW 6TH AVENUE, SUITE 600
PORTLAND, OR 97204
P 503.228.5230 F 503.273.8169

DATE	REVISION	APP'D
01/05/25/22	ISSUE FOR CONSTRUCTION	FSW

Submission Date: 03/07/2022
Drawn: JCB/RMM
Designed: NRS/JBK
Checked: FSW

PROJECT NO. 2015-001-20

W. Hayes Street Improvements
Cascade Avenue to Settlemier Avenue

SHEET NO. SS-8

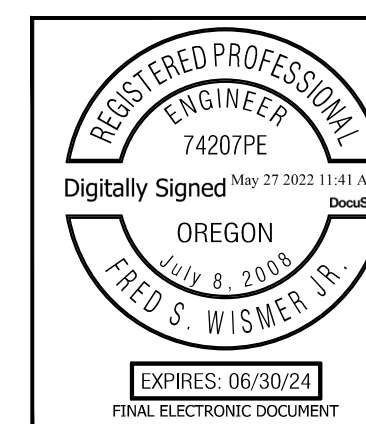

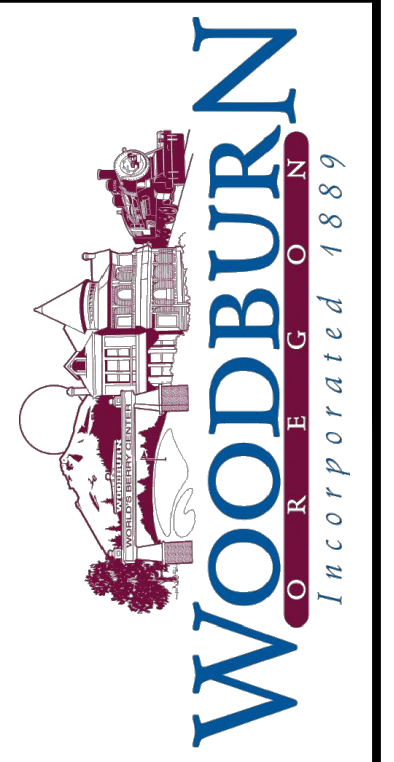
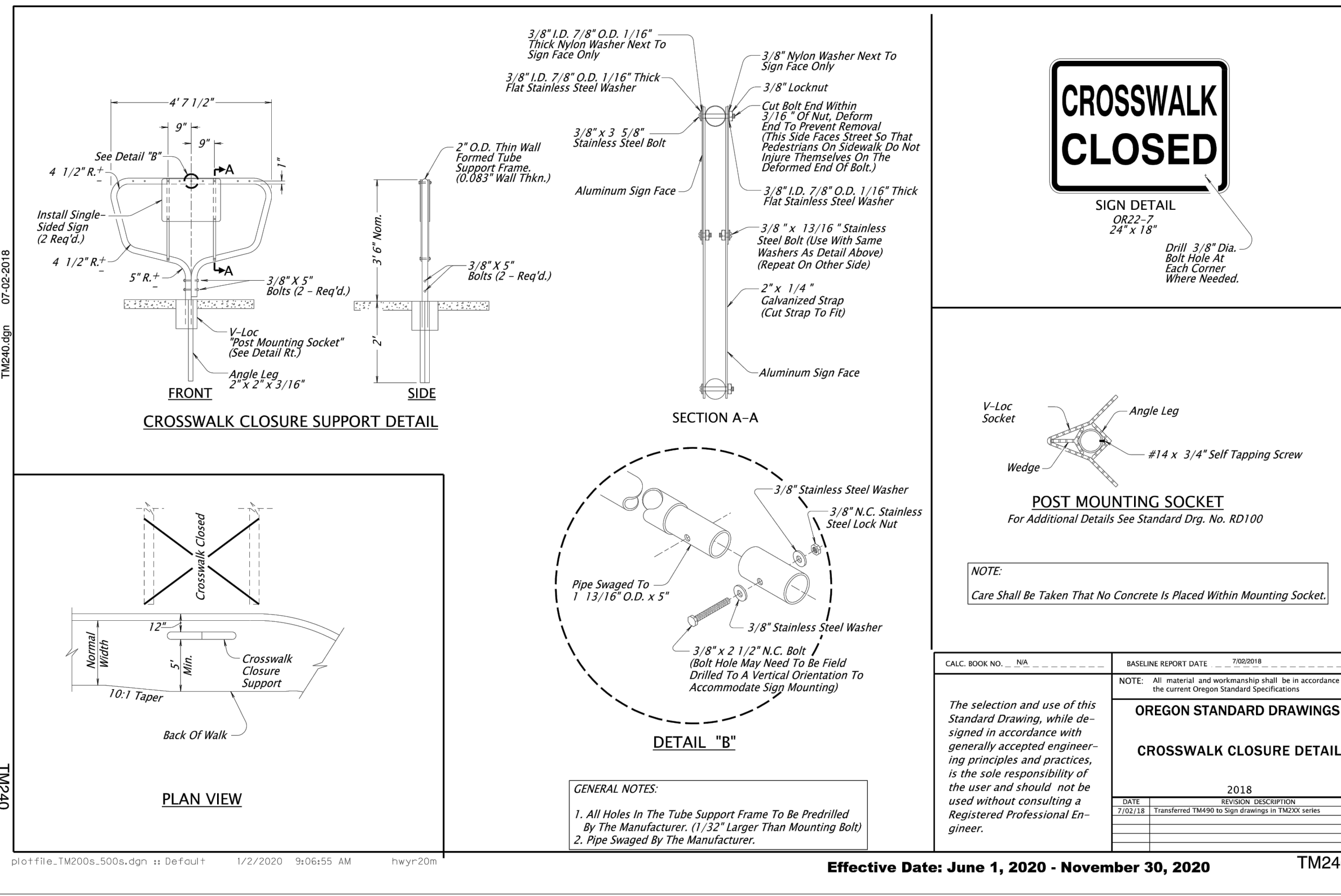
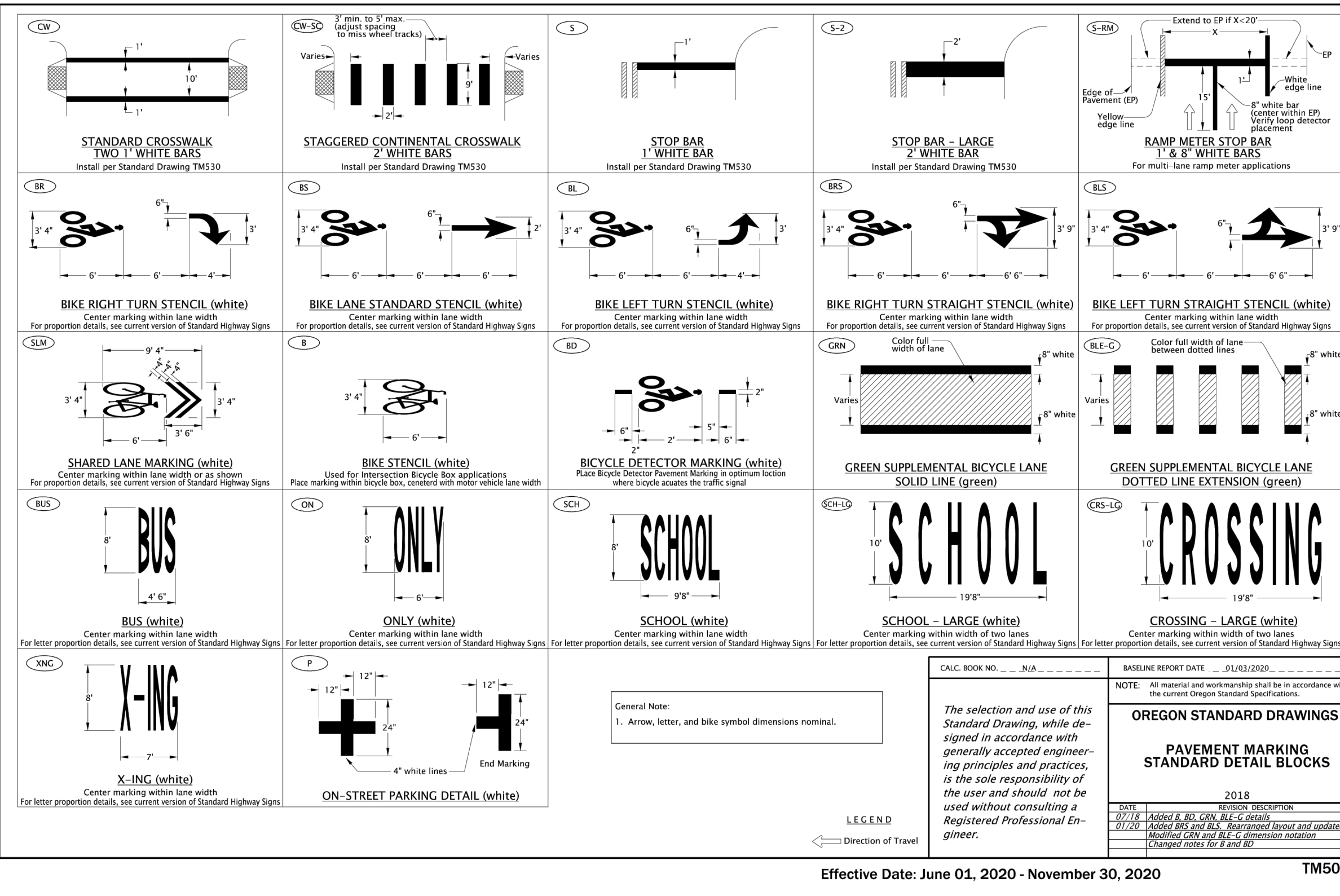
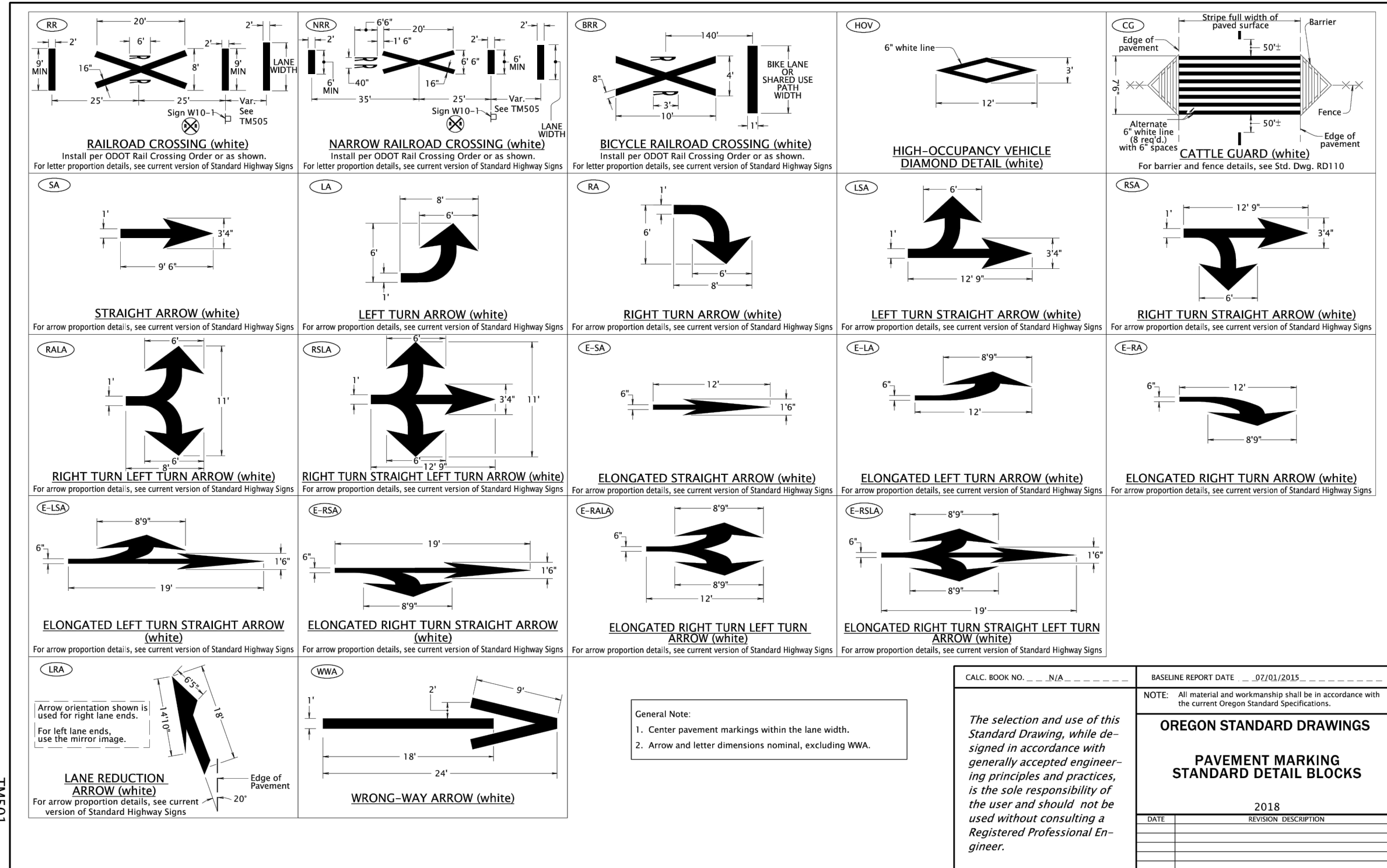
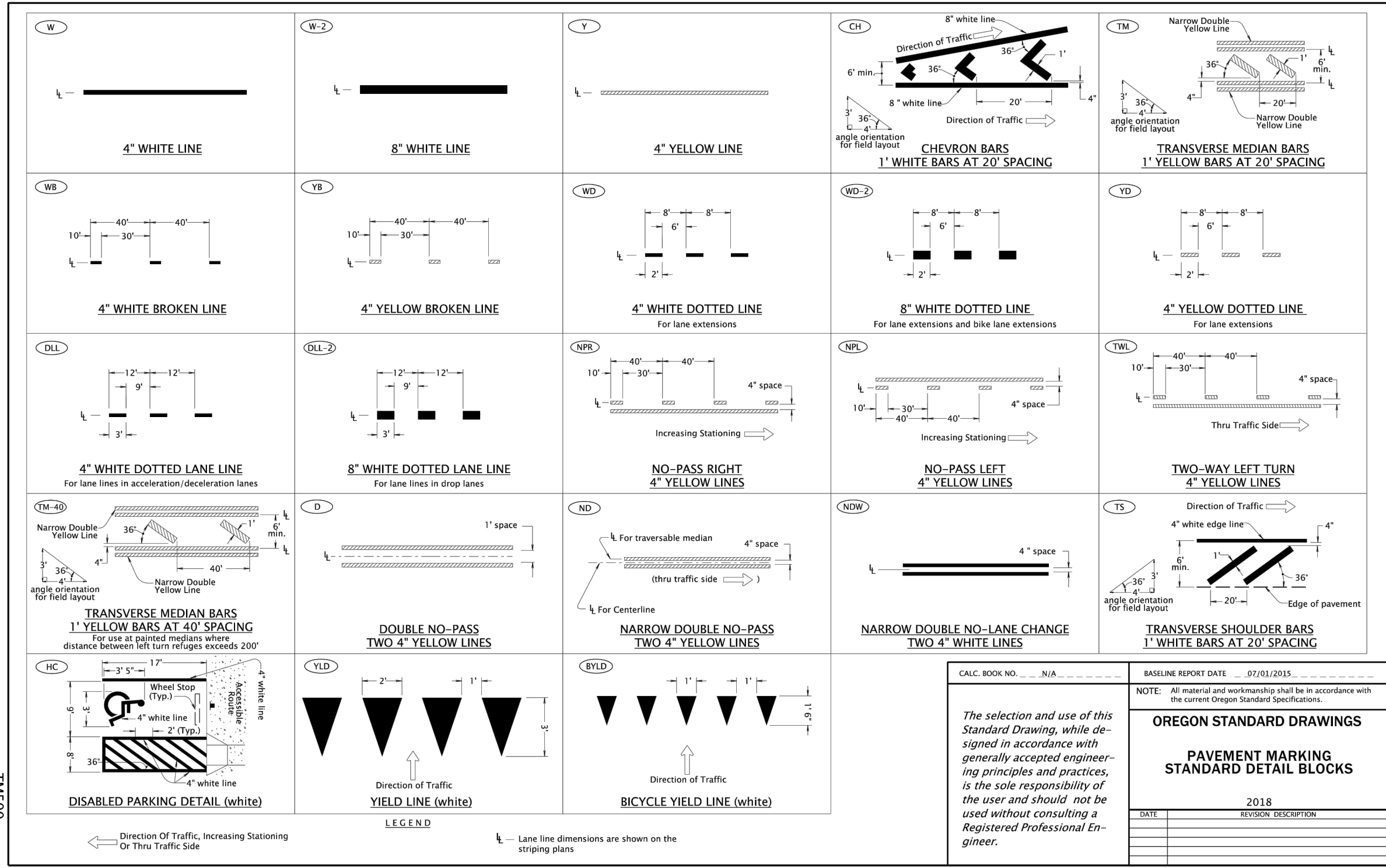

KITTELSON & ASSOCIATES
851 SW 6TH AVENUE, SUITE 600
PORTLAND, OR 97204
P 503.228.5230 F 503.273.8169

DATE	REVISION DESCRIPTION	DATE	REVISION DESCRIPTION
01/05/25/22	ISSUE FOR CONSTRUCTION	05/25/22	REVISION
05/25/22	FSW		AP/D

Submission Date: 03/07/2022
Drawn: JCB/RMM
Designed: NRS/JBK
Checked: FSW

PROJECT NO. 2015-001-20
W. Hayes Street Improvements
Cascade Avenue to Settlemier Avenue
SIGNING AND STRIPING DETAILS
SHEET NO. SS-9

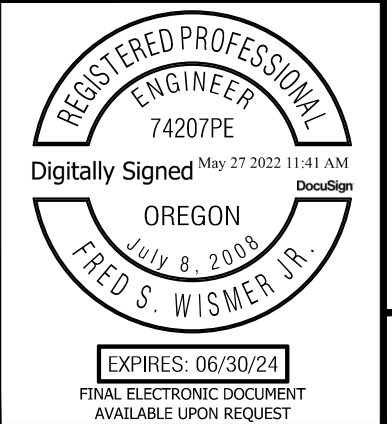

Plot Stamp: 5/25/2022 4:01:48 PM - Fred Wismer
File: H:\24\24512 - W. Hayes Street\design_CD\CD-Signing and Striping-24512.dwg

tm677.dgn 10-JUL-2017

TM677

STAINLESS STEEL CLAMP (SSC) DETAIL
No Scale

Signs mounted to vertical posts that use stainless steel clamps shall not be wider than 36". Use 2 clamps for all signs less than 48" in height and 3 clamps for signs 48" to 60" in height.

SIGN ELEVATION
No Scale

* - L maximum is 14'-0".

SECTION A-A
No Scale

Signs mounted over travel lanes shall use the SIGN SUPPORT BRACKET DETAIL shown on TM618

SECTION B-B
No Scale

GENERAL NOTES

- For Secondary Sign Mounts See TM678.

ROAD NAME SIGN STRUCTURE MOUNT DETAIL

Notes:

- Install resin bonded anchors according to Section 00535.
- Resin bonded anchors shall conform to ASTM A307.
- The hole depths shall develop the pullout strength specified in Table 00535-1.
- Tighten 1/2" dia. anchors using 16 ft.-lb. of torque for waxed galvanized and 40 ft.-lb. of torque for galvanized only connections.

OREGON STANDARD DRAWINGS

SIGN MOUNTS

2018

Effective Date: June 1, 2020 - November 30, 2020 TM677

SINGLE POST ELEVATION
No scale

TWO POST ELEVATION
No scale

THREE POST ELEVATION
No scale

PERMANENT PERFORATED STEEL SQUARE TUBE TABLE

Square Tube Size	(X * Y * Z) in Ft. - Maximum 3 Second Gust Wind Speed (TM671)								
	85 MPH			95 MPH			105 or 110 MPH		
	Number of Posts	Number of Posts	Number of Posts	Number of Posts	Number of Posts	Number of Posts	Number of Posts	Number of Posts	
2"-12 ga.	79	158	237	63	126	189	57	114	171
2 1/2"-12 ga.	136	272	408	109	218	327	98	196	294
2 1/2"-10 ga.	165	330	495	132	264	396	119	238	357
2 1/2" & 2 1/2"-12 ga.	231	462	693	185	370	555	167	334	501

TEMPORARY PERFORATED STEEL SQUARE TUBE TABLE

Square Tube Size	(X * Y * Z) in Ft. - Maximum 3 Second Gust Wind Speed (TM671)								
	85 MPH			95 MPH			105 or 110 MPH		
	Number of Posts	Number of Posts	Number of Posts	Number of Posts	Number of Posts	Number of Posts	Number of Posts	Number of Posts	
2"-12 ga.	125	250	375	100	200	300	90	180	270
2 1/2"-12 ga.	215	430	645	172	344	516	155	310	465
2 1/2"-10 ga.	261	522	783	209	418	627	189	378	567
2 1/2" & 2 1/2"-12 ga.	364	728	1092	292	584	876	263	526	789

BASE REQUIREMENTS

1. Anchor - See Drawing TM687 for PSST anchor foundation details.
 2. Slip - See Drawing TM688 for PSST slip base foundation details.
 3. N/A - Do not use this option.

GENERAL NOTES:

- Perforated Steel Square Supports are designed in accordance with the AASHTO Standard Specifications for Structural Supports for Highway Signs, Luminaires, and Traffic Signals 4th Edition, 2001, 2002, 2003, and 2006 interim revisions.
- The design basic wind speed (3 second gust) shall be according to the wind map shown on TM671.
- Material grade for base hardware connection shall be according to the manufacturer's recommendation and based on crash testing.
- Use 7/8" diameter holes at 1" spacing on each of the 4 sides.
- Steel post shall have a minimum yield stress of 50 ksi.
- Steel shall be galvanized according to ASTM A653 with coating designation G90.
- General design parameters are Kz = 0.87, Cd (sign) = 1.20, and G = 1.14.
- Permanent signing uses an Ir = 0.71 for a recurrence interval of 10 years.
- Temporary signing uses an Ir = 0.45 for a recurrence interval of 1.5 years.
- The sign width to sign height or sign height to sign width ratio shall not exceed 5.0.
- For horizontal and vertical clearances of permanent signs refer to TM200 and of temporary signs refer to TM822.
- Posts protected by barrier or guardrail do not require slip bases.

OREGON STANDARD DRAWINGS

PERFORATED STEEL SQUARE TUBE (PSST) SIGN SUPPORT INSTALLATION

2018

Effective Date: June 1, 2020 - November 30, 2020 TM681

2" ANCHOR DETAIL
No scale

2 1/2" ANCHOR DETAIL
No scale

2" OPTIONAL ANCHOR DETAIL
No scale

PLAN
No scale

General Notes:

- Material grade for base hardware connection shall be according to the manufacturer's recommendation and based on crash testing.
- Anchor steel shall be hot dipped galvanized or approved equal.
- Footing concrete shall be Commercial Grade Concrete (fc = 3000 psi) per Specification 00440. The CGC mixture may be accepted at the site of placement according to 00440.14.
- The estimated concrete volume is .09 cubic yards.

OREGON STANDARD DRAWINGS

PERFORATED STEEL SQUARE TUBE (PSST) ANCHOR FOUNDATION

2018

Effective Date: June 1, 2020 - November 30, 2020 TM687

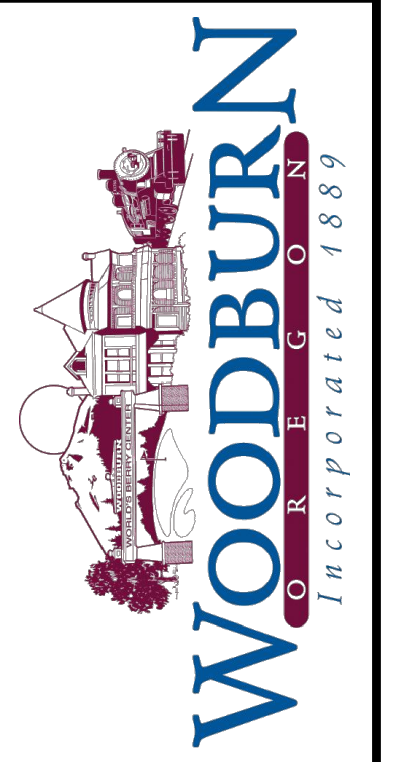

KITTELSON & ASSOCIATES
 851 SW 6TH AVENUE, SUITE 600
 PORTLAND, OR 97204
 P 503.228.5230 F 503.273.8169

DATE	REVISION DESCRIPTION	FSW	APP'D
01/05/25/22	ISSUE FOR CONSTRUCTION		
	REVISION		

Submission Date: 03/07/2022
 Drawn: JCB/RMM Designed: NRS/JBK Checked: FSW

PROJECT NO. 2015-001-20
 W. Hayes Street Improvements
 Cascade Avenue to Settlemier Avenue
 SIGNING DETAILS
 SHEET NO. SS-10

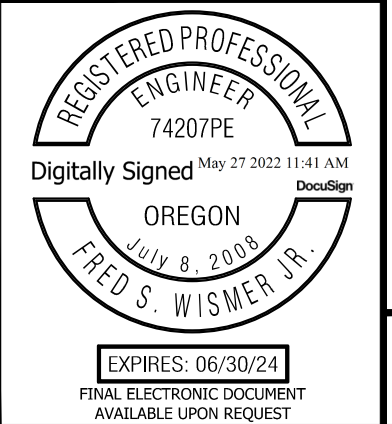

SIGN NO.	SIGN LOCATION ^{4/}	SIGN DIMENSIONS		BORDER WIDTH	RADIUS	ARROW SIZE	SIGN TYPE <small>(PER SEC. 2910 STD. SPECIFICATIONS)</small>	SUB-STRATE <small>PLYWOOD SHEET ALUM. EXTRUDED ALUM.</small>	COLOR ^{1/}					SIGN NO. ^{2/}	TYPE OF SUPPORT													POST		FOOTING		REFER TO OREGON STANDARD DRAWING							REMARKS							
		WIDTH	HEIGHT						BACKGROUND	LEGEND					WOOD	PERFORATED STEEL SQUARE TUBE	TRIANGULAR BASE BREAKAWAY	MULTI-POST BREAKAWAY	STAINLESS STEEL CLAMP (SSC)	SIGNAL POLE MOUNT	BRIDGE RAIL MOUNT	STRUCTURE MOUNT	CANTILEVER	SIGN BRIDGE	"H" FRAME	ROUTE MARKER FRAME	MILEPOST MARKER POST	ADJUSTABLE SIGN BRACKET	MAST ARM STREET NAME SIGN MOUNT	CROSSWALK CLOSURE BARRICADE	C 4 X 5.4	C 4 X 7.25	SECONDARY SIGN MOUNT	LENGTH	SIZE <small>(BASED ON ESTIMATED LENGTH)</small>	LENGTH <small>(MUST BE FIELD VERIFIED)</small>	LOCATION ^{3/}	MIN. DEPTH ^{5/}		REFER TO OREGON STANDARD DRAWING						
										ASTM TYPE IX	ASTM TYPE III OR TYPE IV	ASTM TYPE VII OR TYPE IV	NON-REFLECTIVE																											TM600 & 601	TM602	TM635	TM670	TM675	TM676 & 206	TM677 & 679
118	STA. 19+45.79 R	36"	48"				S1-1, W16-9P	X	FYG				BK	118	X											2.5"	13'-0"	8'-0"	2'-0"			X	X													
	STA. 24+19.91 L	36"	48"				S1-1, W16-9P	X	FYG				BK		X											2.5"	13'-0"	8'-0"	2'-0"			X	X													
122	STA. 29+69.24 R	12"	18"				R7-9	X	SW				R	122	X											2.5"	10'-6"	8'-0"	2'-0"			X	X													
	STA. 34+26.09 R	12"	18"				R7-9	X	SW				R		X											2.5"	10'-6"	8'-0"	2'-0"			X	X													
125	STA. 16+71.88 R	24"	48"				OS5-5, OS4-8	X	FYG,SW				BK	125	X											2.5"	13'-0"	8'-0"	2'-0"			X	X													
	STA. 23+26.77 R	24"	48"				OS5-5, OS4-8	X	FYG,SW				BK		X											2.5"	14'-6"	8'-0"	2'-0"			X	X													
	STA. 26+01.87 L	24"	48"				OS5-5, OS4-8	X	FYG,SW				BK		X											2.5"	14'-6"	8'-0"	2'-0"			X	X													
	STA. 23+38.83 L	24"	48"				OS5-5, OS4-8	X	FYG,SW				BK		X											2.5"	13'-0"	8'-0"	2'-0"			X	X													
126	STA. 16+72.04 L	24"	30"				S5-2	X	SW				BK	126	X											2.5"	11'-6"	8'-0"	2'-0"			X	X													
	STA. 26+04.44 R	24"	30"				S5-2	X	SW				BK		X											2.5"	11'-6"	8'-0"	2'-0"			X	X													
127	STA. 21+59.51 R	36"	36"				R1-5B	X	SW				BK	127	X											2.5"	12'-0"	8'-0"	2'-0"			X	X													
	STA. 22+12.55 L	36"	36"				R1-5B	X	SW				BK		X											2.5"	12'-0"	8'-0"	2'-0"			X	X													
128	STA. 6+47.49 C	24"	30"				R4-7	X	SW				BK	128	X											2.5"	11'-6"	2'-6"	2'-0"			X	X													
	STA. 6+81.86 C	24"	30"				R4-7	X	SW				BK		X											2.5"	11'-6"	2'-6"	2'-0"			X	X													
133	W Hayes Street	18"	18"				OM4-1	X	R					133	X											2.5"	8'-6"	1'-0"	2'-0"			X	X						Object Marker to be Placed Behind Curb at End of W Hayes Street							
	W Hayes Street	18"	18"				OM4-1	X	R						X											2.5"	8'-6"	1'-0"	2'-0"			X	X						Object Marker to be Placed Behind Curb at End of W Hayes Street							
135	STA. 20+51.63 L	24"	18"				OR22-7	X	SW				BK	135									X																X Signs mounted on both sides of the barricade							
	STA. 20+51.63 L	24"	18"				OR22-7	X	SW				BK										X															X Signs mounted on both sides of the barricade								
	STA. 20+98.57 L	24"	18"				OR22-7	X	SW				BK										X															X Signs mounted on both sides of the barricade								
	STA. 20+98.57 L	24"	18"				OR22-7	X	SW				BK										X															X Signs mounted on both sides of the barricade								
	STA. 25+05.91 L	24"	18"				OR22-7	X	SW				BK										X															X Signs mounted on both sides of the barricade								
	STA. 25+05.91 L	24"	18"				OR22-7	X	SW				BK										X															X Signs mounted on both sides of the barricade								
	STA. 29+07.60 L	24"	18"				OR22-7	X	SW				BK										X															X Signs mounted on both sides of the barricade								
	STA. 29+07.60 L	24"	18"				OR22-7	X	SW				BK										X															X Signs mounted on both sides of the barricade								
	STA. 37+15.52 L	24"	18"				OR22-7	X	SW				BK										X															X Signs mounted on both sides of the barricade								
	STA. 37+15.52 L	24"	18"				OR22-7	X	SW				BK										X															X Signs mounted on both sides of the barricade								
	STA. 20+37.88 R	24"	18"				OR22-7	X	SW				BK										X															X Signs mounted on both sides of the barricade								
	STA. 20+37.88 R	24"	18"				OR22-7	X	SW				BK										X															X Signs mounted on both sides of the barricade								
	STA. 21+15.64 R	24"	18"				OR22-7	X	SW				BK										X															X Signs mounted on both sides of the barricade								
	STA. 21+15.64 R	24"	18"				OR22-7	X	SW				BK										X															X Signs mounted on both sides of the barricade								
	STA. 25+05.91 R	24"	18"				OR22-7	X	SW				BK										X															X Signs mounted on both sides of the barricade								
	STA. 25+05.91 R	24"	18"				OR22-7	X	SW				BK										X															X Signs mounted on both sides of the barricade								
	STA. 28+89.02 R	24"	18"				OR22-7	X	SW				BK										X															X Signs mounted on both sides of the barricade								
	STA. 28+89.02 R	24"	18"				OR22-7	X	SW				BK										X															X Signs mounted on both sides of the barricade								
	STA. 37+05.33 R	24"	18"				OR22-7	X	SW				BK										X															X Signs mounted on both sides of the barricade								
	STA. 37+05.33 R	24"	18"				OR22-7	X	SW				BK										X															X Signs mounted on both sides of the barricade								
136		24"	24"				W14-1	X	YG				BK	136																								Install sign on existing post located on SW corner of Hayes St and 5th St								
137	STA. 21+68.40 R	12"	36"				OM3-L	X	BK				Y		X											2"	5'-6"	10'-8"	2'-0"			X	X						Object Marker to be installed within midblock crossing.							
	STA. 22+05.00 R	12"	36"				OM3-L	X	BK				Y		X											2"	5'-6"	10'-8"	2'-0"			X	X						Object Marker to be installed within midblock crossing.							

1/ BK= BLACK
BL= BLUE
BR= BROWN
FYG= FLUORESCENT YELLOW-GREEN
G= GREEN
O= ORANGE
R= RED
RB= RED-BLUE
SW= SILVER-WHITE
W= WHITE
Y= YELLOW
YG= YELLOW-GREEN

2/ NOTE: L,C,R ARE LOCATIONS OF POSTS
FACING THE SIGN.
L=LEFT POST
C=CENTER POST
R=RIGHT POST

3/ DISTANCE FROM EDGE OF TRAVEL LANE, FACE OF CURB, GUARDRAIL, OR BARRIER TO THE CENTERLINE OF FOOTING. FOR ADDITIONAL INFORMATION SEE STANDARD DRAWINGS TM601, TM602, AND TM635.

4/ NOTE: THE LOCATIONS SHOWN ARE APPROXIMATE EXCEPT FOR SPEED ZONES, SCHOOL ZONES, OBJECT MARKERS AND MILEPOST MARKERS. EXACT LOCATIONS ARE TO BE DETERMINED BY THE ENGINEER.

5/ MINIMUM DEPTH OF FOOTING FOR TRIANGULAR BASE BREAKAWAY AND MULTI-POST BREAKAWAY INSTALLATIONS IS FOR A 2' DIAMETER FOOTING. FOR ADDITIONAL INFORMATION SEE STANDARD DRAWINGS TM601 AND TM602.

Drawn: JCB/RMM
Designed: NRS/JBK
Checked: FSW

Submission Date:
03/07/2022

PROJECT NO.
2015-001-20

W. Hayes Street Improvements
Cascade Avenue to Settlemier Avenue

ISSUE FOR CONSTRUCTION
REVISION

SIGNING DETAILS

SHEET NO.
SS-12

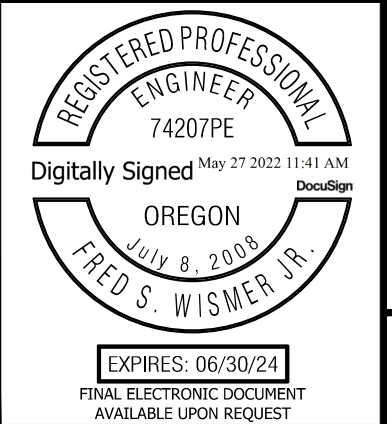

LEGEND

CONTROLLERS & CABINETS

- Install a model 332S cabinet & control equipment with riser frame. Orient louvered door as shown.
- Install ATC controller
- Install base Mounted Service cabinet, 120/240 volt metered for signal system
- Remove existing service cabinet

POLES

- Install (T=type) standard traffic signal mast arm pole. See Pole Entrance Chart Sht. TS-4
- Install (L=Length) foot traffic signal mast arm
- Install pedestrian signal pedestal with frangible base
- Retain and protect existing power pole
- Install (L=Length) foot luminaire arm
- Remove existing traffic signal mast arm pole
- Remove existing mast arm

SIGNALS

- Install phase (Ph=phase) vehicle signal with retro-reflective strips on back-plates, see detail on Std. Dwg. No. TM460.
- Install phase (Ph=phase) countdown pedestrian signal with clamshell mount and pushbutton mount. Include phase (Ph=phase) audible pedestrian signal.
- Remove existing vehicle signal

SIGNS

- Install Aluminum Street Name Sign "W Hayes St" on Mast Arm
- Install Aluminum Street Name Sign "W Settlemier Ave" on Mast Arm
- Install Aluminum (30"x36") LEFT TURN ONLY sign (R3-5L)
- Install Aluminum (30"x36") RIGHT TURN ONLY sign (R3-5R)
- Install Aluminum (30"x36") TURNING VEHICLES YIELD TO PEDS sign (R10-15L)
- Remove existing interior illuminated sign

LUMINAIRES

- Install Leotek, 88 Watt, 700mA, 40 LED GCM2-40H-MV-WW-2R-GY-700-PCR7-RWG-WL-FDC Bond luminaire to pole grounding terminal
- Install Photocontrol Electronic Relay on Fixture (See Project Specifications)

JUNCTION BOXES

- Install 17"x10"x12" (min. dimension) precast concrete junction box
- Install 17"x10"x12" (min. dimension) precast concrete junction box with concrete apron
- Install 30"x17"x12" (min. dimension) precast concrete junction box with concrete apron
- Install 30"x17"x18" (min. dimension) precast concrete junction box with concrete apron (See Oregon Standard Dwg. TM472 for Details)

CONDUITS

- Install (S=size) inch conduit
- Install Conduit and Wire as Required by Power Company
- Install conduit by horizontal directional drilling, open trench not allowed

MISCELLANEOUS

- Power Source Location. To be coordinated by other
- Install Single Sided Rapid Rectangular Flashing Beacon. See details on sheet TS-5
- Install Double Sided Rapid Rectangular Flashing Beacon. See details on sheet TS-5

FIRE PREEMPTION

- Install channel (Ch=channel), fire preemption detector feeder cable
- Install channel (Ch=channel), (N=number) barrel fire preemption detector unit

DETECTION

- Install near-range radar detector unit (T=Radar)
- Install far-range radar detector unit (T=Radar)
- Install Wavetronix Click 656 SDLC radar interface unit, SDLC cable, and shelf rack

WIRES & CABLES

- Install (X=number of cables) control cable(s) with (N=number) (G=AWG wire size) AWG conductors.
- Install poly pull line (500 FT/LB minimum strength)
- Install radar control cables (T=Radar)
- Retain and protect existing wiring.
- Remove existing wiring.
- Install (N=number) No. G (G=AWG Wire Size) THWN Wires
- Install (N=number) No. G (G=AWG Wire Size) XHHW Wires

GENERAL NOTES:

1. All materials and workmanship shall conform to Special Provisions and the 2021 Oregon Standard Specifications for Construction, and the Oregon Standard Drawings listed below.
2. The contractor shall supply all equipment, materials, and labor required for the signal operations shown on this plan.
3. The contractor shall verify the locations of existing utilities and coordinate this work with the utility companies/agencies to eliminate any conflicts.
4. The contractor shall field verify the location of all signal equipment before installation.
5. Signal timing will be provided by ODOT.
6. Retain and protect existing signal and detection during construction until new signal installation is complete and ready for turn-on. Maintain minimum signal operation down time.
7. All junction boxes shall be placed in sidewalk or concrete apron.
8. Install #12 stranded copper (orange) tracer wire in all conduits. Ground all tracer wires.
9. Conduit shall be placed in the same trench with other conduits when possible.
10. Top of signal and pedestrian foundations shall match top of finished grade of sidewalk.
11. All conduit runs shall be within right-of-way.
12. Install poly pull tape (1,200 LBF min. strength, non conductive) in all conduits.
13. All underground conduits and fittings shall be Schedule 80 PVC.

SIGNAL MOUNTING OPTIONS

B = Adjustable skybracket (No Tenon)

SIGNAL HEAD OPTIONS

2 = 12" R, 12" Y, 12" G
6L = 12" RLTA, 12" YLTA, 12" FYLTA, 12" GLTA

SIGN MOUNTING OPTIONS

AB = Adjustable skybracket (No Tenon)

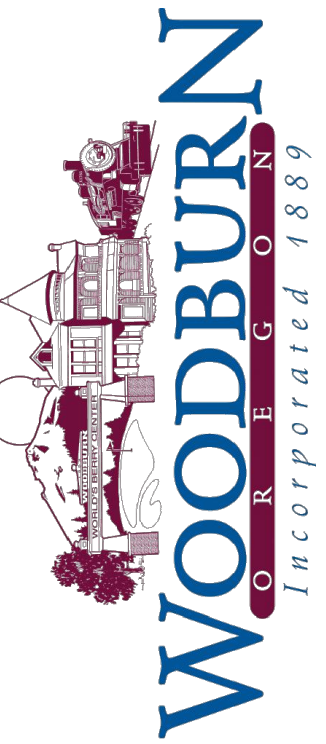

851 SW 6TH AVENUE, SUITE 600
PORTLAND, OR 97204
P 503.228.5230 F 503.273.8169

REV	DATE	DESCRIPTION	APP'D
0	05/25/22	ISSUE FOR CONSTRUCTION	FSW
		REVISION	

Submission Date: 03/07/2022

Drawn: JBK, Designed: JBK, Checked: WES

PROJECT NO. 2015-001-20

W. Hayes Street Improvements
Cascade Avenue to Settlemier Avenue

SIGNAL LEGEND AND NOTES

SHEET NO. TS-1

ACCOMPANIED BY DWGS.
TM223, TM450, TM457, TM460, TM462
TM466, TM465, TM467, TM470, TM471,
TM472, TM482, TM485, TM488, TM650,
TM651, TM652, TM653, TM654
DET4437, DET4681

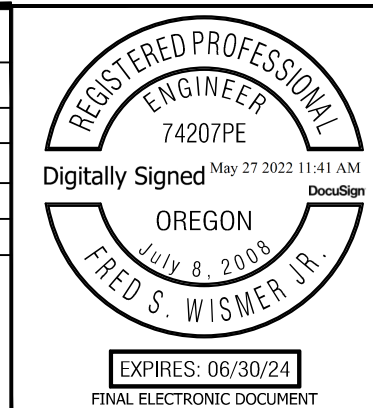

01	05/25/22	#	DATE
02			
03			
04			
05			
06			
07			
08			
09			
10			
11			
12			
13			
14			
15			
16			
17			
18			
19			
20			
21			
22			
23			
24			
25			
26			
27			
28			
29			
30			
31			
32			
33			
34			
35			
36			
37			
38			
39			
40			
41			
42			
43			
44			
45			
46			
47			
48			
49			
50			
51			
52			
53			
54			
55			
56			
57			
58			
59			
60			
61			
62			
63			
64			
65			
66			
67			
68			
69			
70			
71			
72			
73			
74			
75			
76			
77			
78			
79			
80			
81			
82			
83			
84			
85			
86			
87			
88			
89			
90			
91			
92			
93			
94			
95			
96			
97			
98			
99			
100			

Submission Date: 03/07/2022
 Drawn: JBK
 Designed: JBK
 Checked: WES

PROJECT NO. 2015-001-20

W. Hayes Street Improvements
 Cascade Avenue to Settlemier Avenue

SIGNAL PLANS

SHEET NO. TS-2

- GENERAL NOTES:**
1. FIELD VERIFY MEASUREMENT BEFORE CONSTRUCTION.
 2. POLE STATIONING BASED OFF OF N SETTLEMIER AVE.
 3. SEE SHEET TS-01 FOR LEGEND.
 4. ARROWS SHOWN FOR VEHICLE MOVEMENTS ONLY.
 5. POWER SOURCE LOCATION TO BE CONFIRMED.

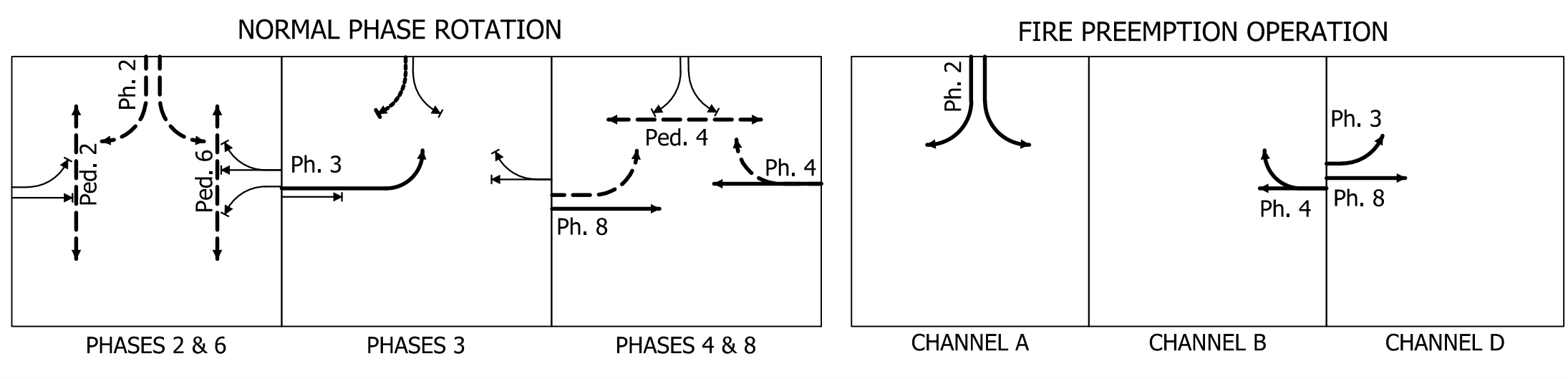
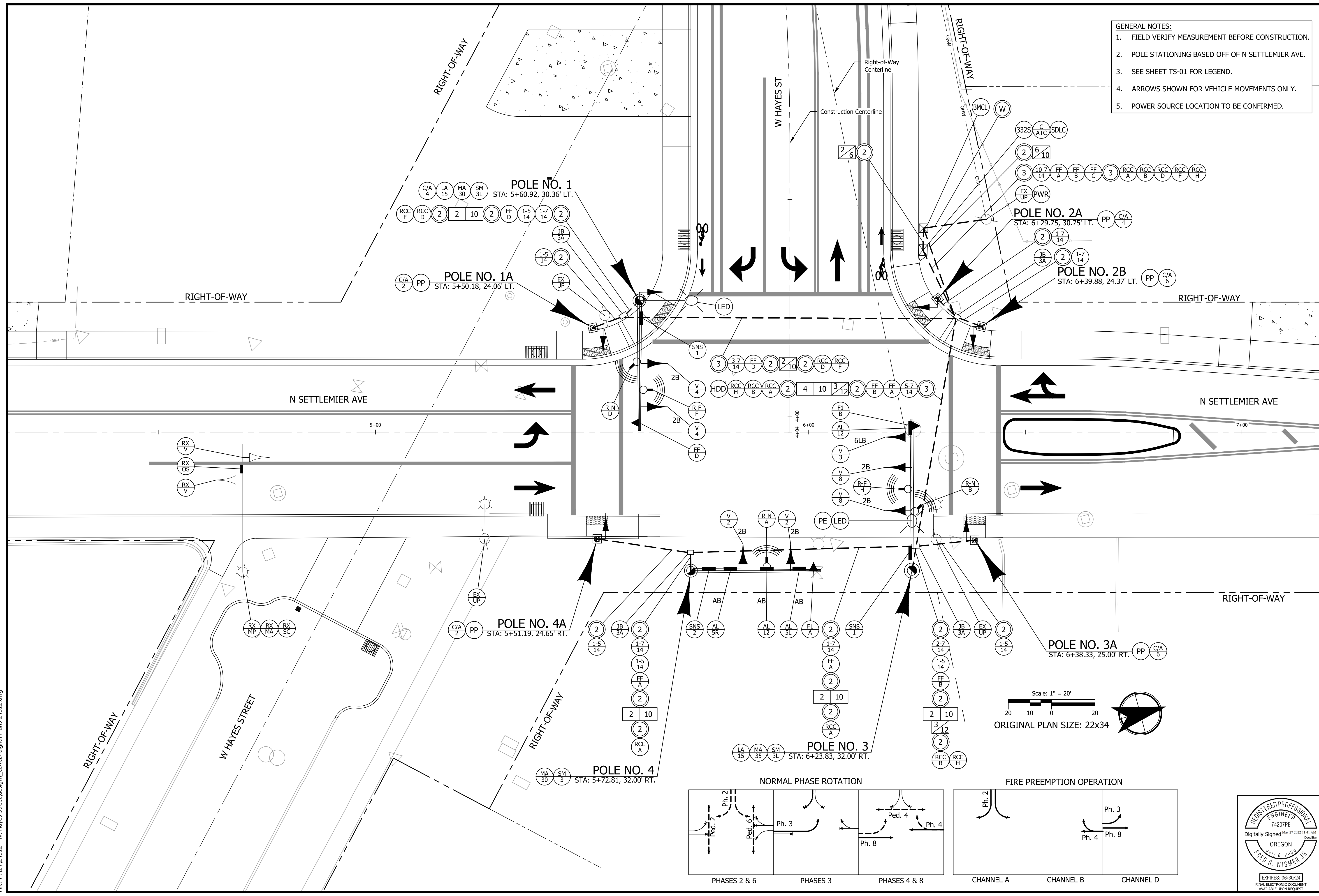

Plot Stamp: 5/25/2022 4:02:26 PM - Fred Wismer
 File: H:\24\24512 - W. Hayes Street\design\CD\CD-Signal-Plans-24512.dwg



EXPIRES: 06/30/24
 FINAL ELECTRONIC DOCUMENT
 AVAILABLE UPON REQUEST

Plot Stamp: 5/27/2022 11:37:57 AM - Fred Wismer
 File: H:\24\24512 - W. Hayes Street\design\CD\CD-Signal-Plans-24512.dwg

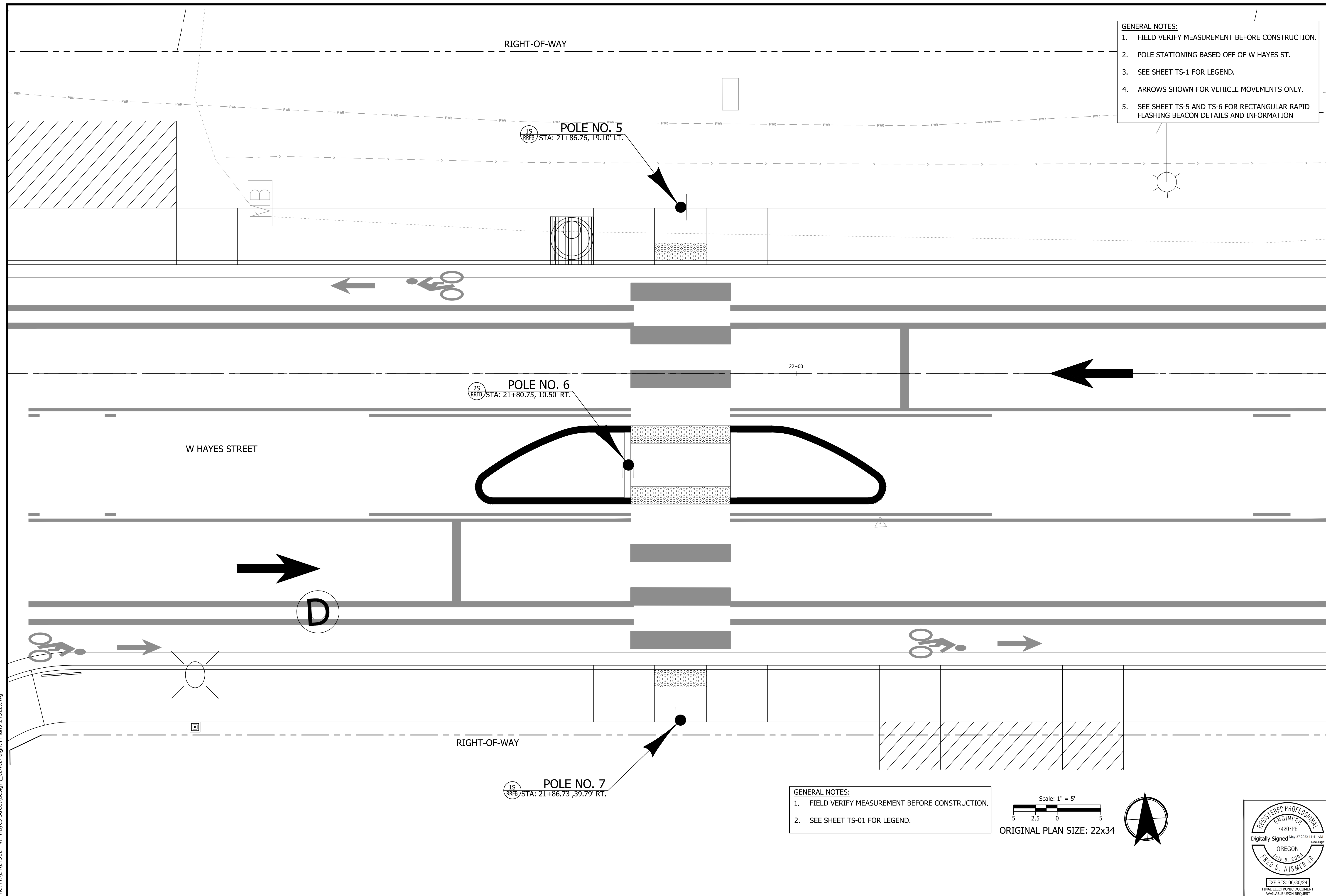

GENERAL NOTES:

1. FIELD VERIFY MEASUREMENT BEFORE CONSTRUCTION.
2. POLE STATIONING BASED OFF OF W HAYES ST.
3. SEE SHEET TS-1 FOR LEGEND.
4. ARROWS SHOWN FOR VEHICLE MOVEMENTS ONLY.
5. SEE SHEET TS-5 AND TS-6 FOR RECTANGULAR RAPID FLASHING BEACON DETAILS AND INFORMATION

GENERAL NOTES:

1. FIELD VERIFY MEASUREMENT BEFORE CONSTRUCTION.
2. SEE SHEET TS-01 FOR LEGEND.

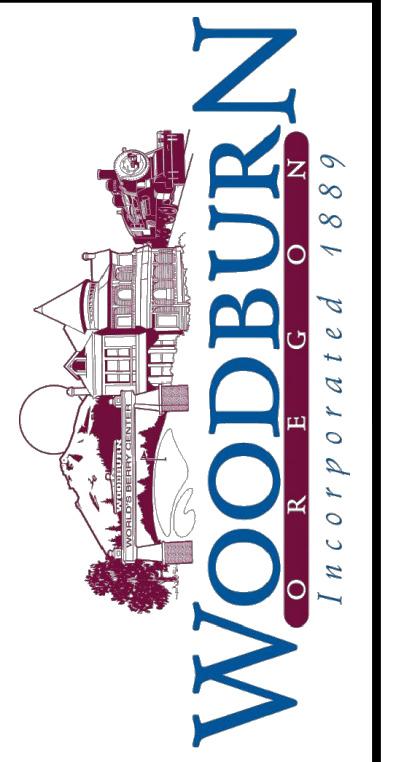
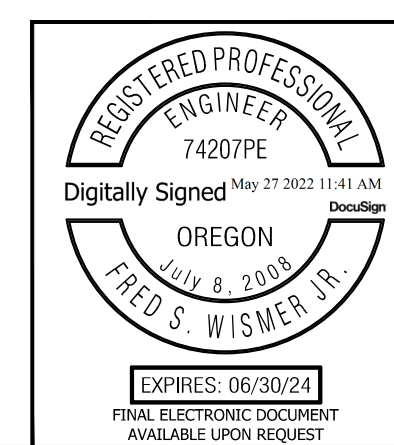
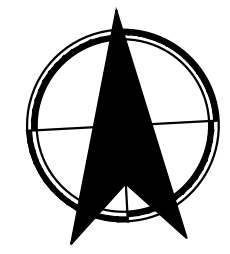
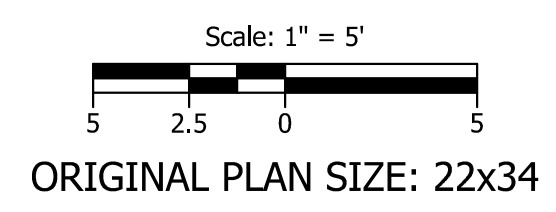

KITTELSON & ASSOCIATES
 851 SW 6TH AVENUE, SUITE 600
 PORTLAND, OR 97204
 P 503.228.5230 F 503.273.8169

NO.	DATE	REVISION	APP'D.
0	05/25/22	ISSUE FOR CONSTRUCTION	FSW

Submission Date: 03/07/2022
 Drawn: JBK Designed: JBK Checked: WES
 PROJECT NO. 2015-001-20

W. Hayes Street Improvements
 Cascade Avenue to Settlemier Avenue
 RECTANGULAR RAPID FLASHING BEACON PLAN

SHEET NO. TS-3

POLE ENTRANCE CHART

POLE #	DWG NO	TYPE	EQUIPMENT ON POLE								EQUIPMENT ON MAST ARM OR SPAN WIRE (LENGTH IN FEET AND EQUIPEMTN TYPE)								LUMINAIRE				FIXTURES		FOUNDATION INFORMATION			
			PED SIGNAL DEG	PUSH BUTT N DEG	TERM CABINET DEG	SIGN DEG	VEHICLE SIGNAL DEG	RADAR DEG	SERVICE DEG	SOLAR MOUNT	ARM LENGTH	D1	D2	D3	D4	D5	D6	D7	D8	ARM LENGTH	ARM DEGREE	MOUNTING HEIGHT	TYPE	DISTRIBU TION	INITIAL LUMENS	REQUIRED FOUNDATIION DEPTH	FOUDATION CONTOL POINT ELEVATION	TOP OF ANCHOR ROD ELEVATION
1	TS-2	SML	180	340	180	-	-	-	-	-	30'	2.0'	5.5'	9.5'	15.5'	16.5'	26.0'	-	-	15'	270	35	LED	2R	10,230	12.0'	-	-
1A	TS-2	PP	0	90	-	-	-	-	-	-	-	-	-	-	-	-	-	-	-	-	-	-	-	-	2.0'	-	-	
2A	TS-2	PP	90	230	-	-	-	-	-	-	-	-	-	-	-	-	-	-	-	-	-	-	-	-	2.0'	-	-	
2B	TS-2	PP	180	15	-	-	-	-	-	-	-	-	-	-	-	-	-	-	-	-	-	-	-	-	2.0'	-	-	
3	TS-2	SML	-	-	180	-	-	-	-	-	35'	1.5'	2.0'	4.0'	12.0'	16.0'	21.0'	22.0'	31.0'	15'	0	35	LED	2R	10,230	12.0'	-	-
3A	TS-2	PP	0	180	-	-	-	-	-	-	-	-	-	-	-	-	-	-	-	-	-	-	-	-	2.0'	-	-	
4	TS-2	SM	-	-	180	-	-	-	-	-	30'	1.5'	5.0'	7.0'	12.5'	12.5'	18.0'	21.0'	26.0'	-	-	-	-	-	-	12.0'	-	-
4A	TS-2	PP	0	180	-	-	-	-	-	-	-	-	-	-	-	-	-	-	-	-	-	-	-	-	2.0'	-	-	
5	TS-4	RRFB	90	180	-	-	-	-	-	-	-	-	-	-	-	-	-	-	-	-	-	-	-	-	3.0'	-	-	
6	TS-4	RRFB	90 / 270	90	-	-	-	-	-	-	-	-	-	-	-	-	-	-	-	-	-	-	-	-	3.0'	-	-	
7	TS-4	RRFB	270	0	-	-	-	-	-	-	-	-	-	-	-	-	-	-	-	-	-	-	-	-	3.0'	-	-	

*POLE FURNISHED BY CITY
 **SIGN REPLACES EXISTING ILLUMINATED SIGN AT SAME LOCATION

LEGEND

- SML = ODOT SIGNAL MAST ARM POLE.
- SM = ODOT SIGNAL MAST ARM POLE WITH LUMINAIRE
- PP = PEDESTRIAN PEDESTAL WITH FRANGIBLE BASE
- RRFB= RECTANGULAR RAPID FLASHING BEACON
- EX = EXISTING TRAFFIC SIGNAL MAST ARM POLE
- RX = TO BE REMOVED
- V2 = TRAFFIC SIGNAL TYPE 2, ADJUSTABLE BRACKET MOUNT TENON NOT REQUIRED (SEE STD. DWG. TM462)
- V6L = TRAFFIC SIGNAL TYPE 6L, ADJUSTABLE BRACKET MOUNT TENON NOT REQUIRED (SEE STD. DWG. TM462)
- SNS = STREET NAME SIGN ON MAST ARM MOUNT (SEE STD DWG. TM679)
- F = FIRE PREEMPTION (SEE STD. DWG. TM465)
- RAD = WAVETRONIX RADAR
- VP = VEHICLE SIGNAL PEDESTAL WITH TRANSFORMER BASE (SEE SHEET TS-13)

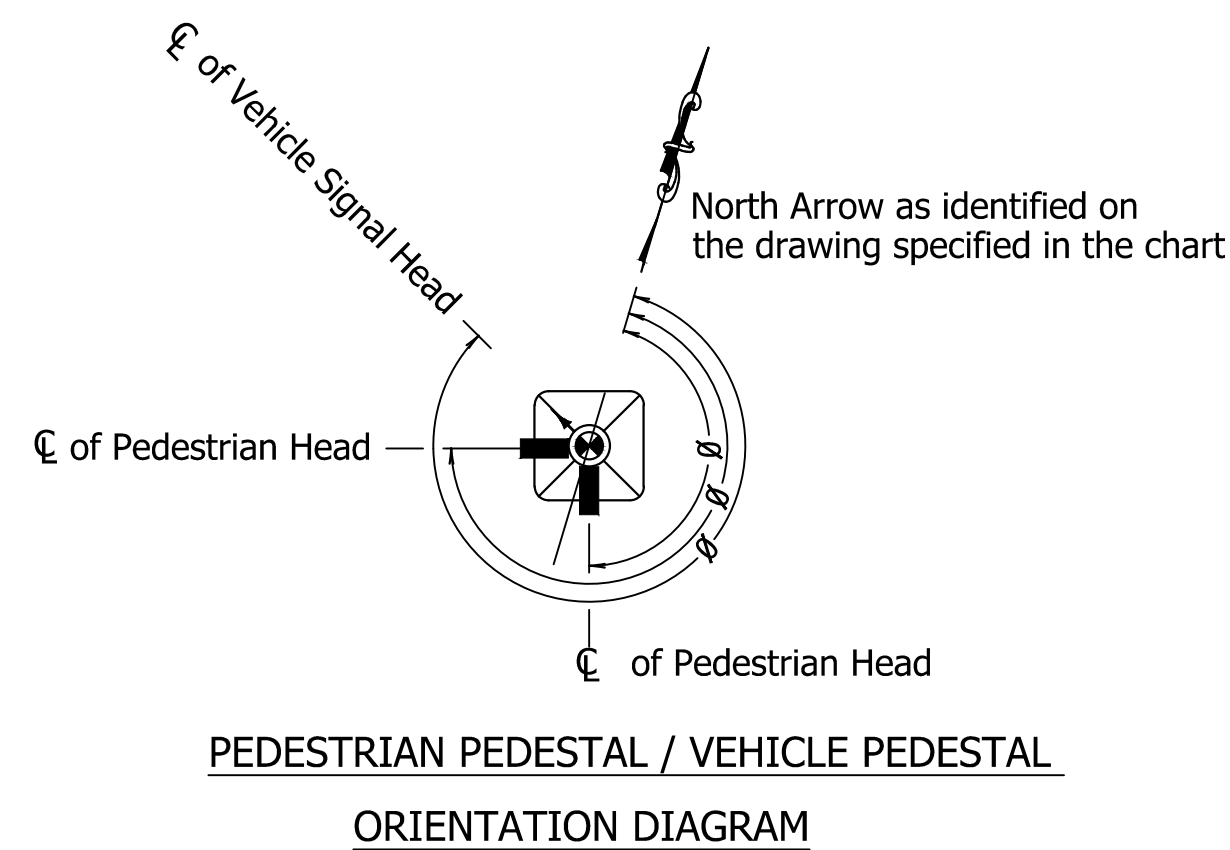

NOTE:
 Equipment shown on the orientation diagram is a clarification of angles of equipment that may be located on a Pedestrian Pedestal or Vehicle Pedestal.

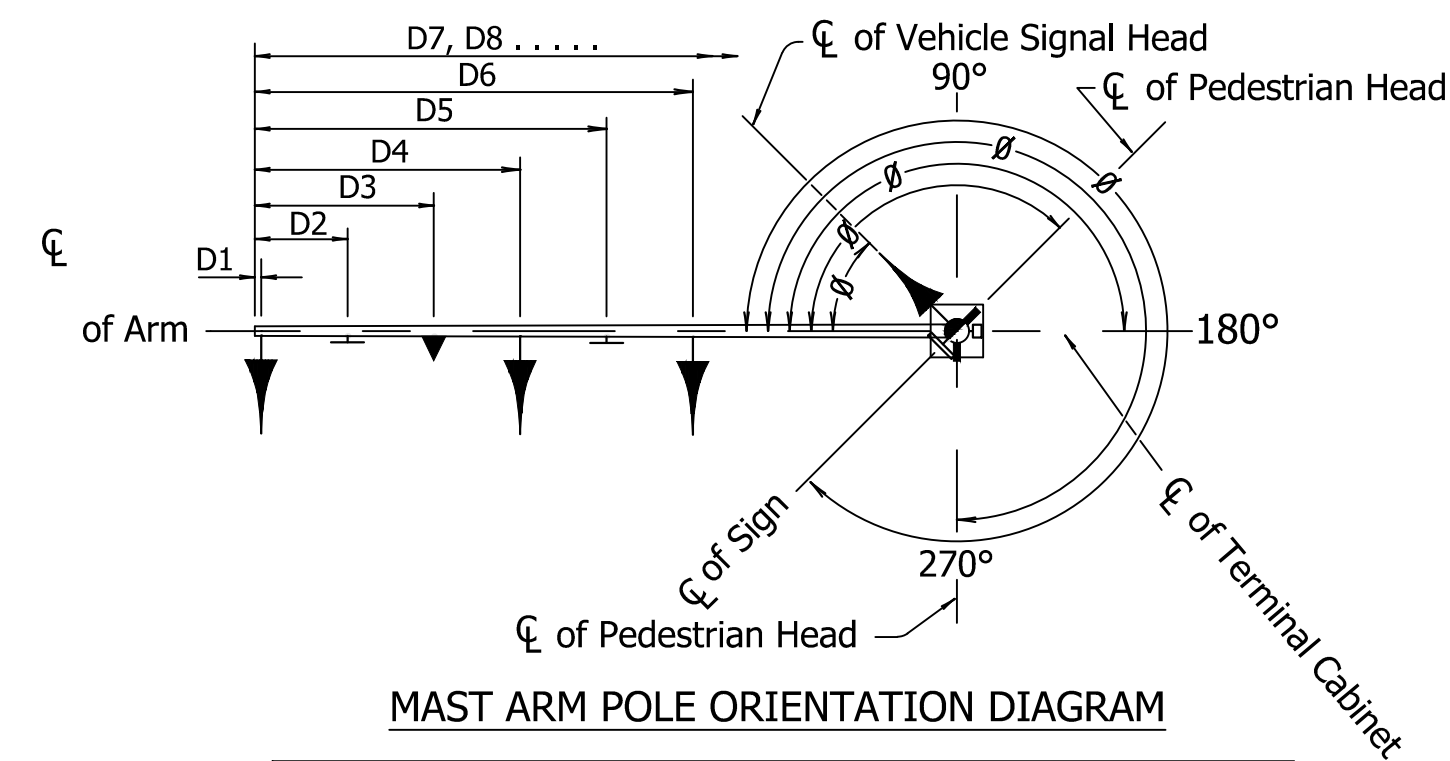

NOTE:
 Equipment shown on orientation diagram is clarification of distance and angles of equipment that may be located on a Mast Arm or Signal Pole.

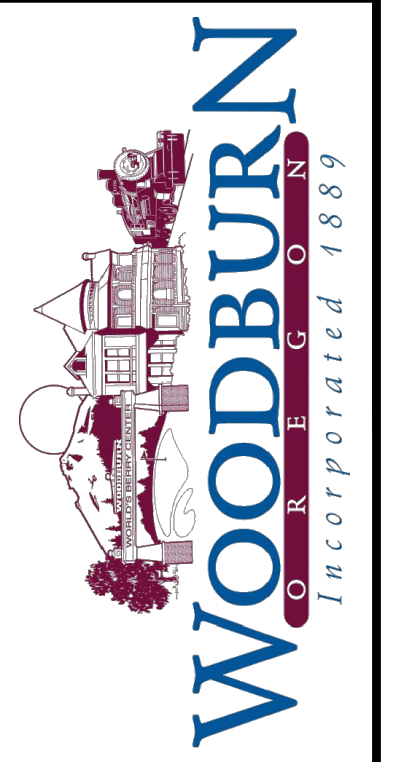
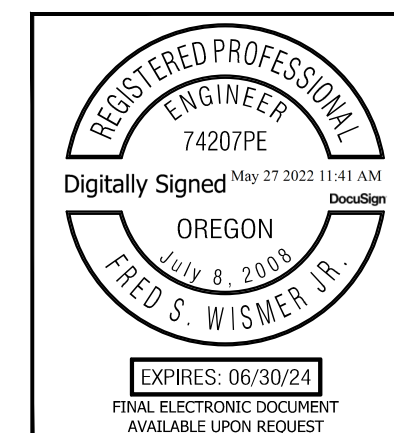

KITTELSON & ASSOCIATES
 851 SW 6TH AVENUE, SUITE 600
 PORTLAND, OR 97204
 P 503.228.5230 F 503.273.8169

DATE	REVISION	APP'D
01/05/25/22	ISSUE FOR CONSTRUCTION	FSW

Submission Date: 03/07/2022
 Drawn: JBK, Designed: JBK, Checked: WES

PROJECT NO. 2015-001-20

W. Hayes Street Improvements
 Cascade Avenue to Settlemier Avenue

POLE ENTRANCE CHART

SHEET NO. TS-4

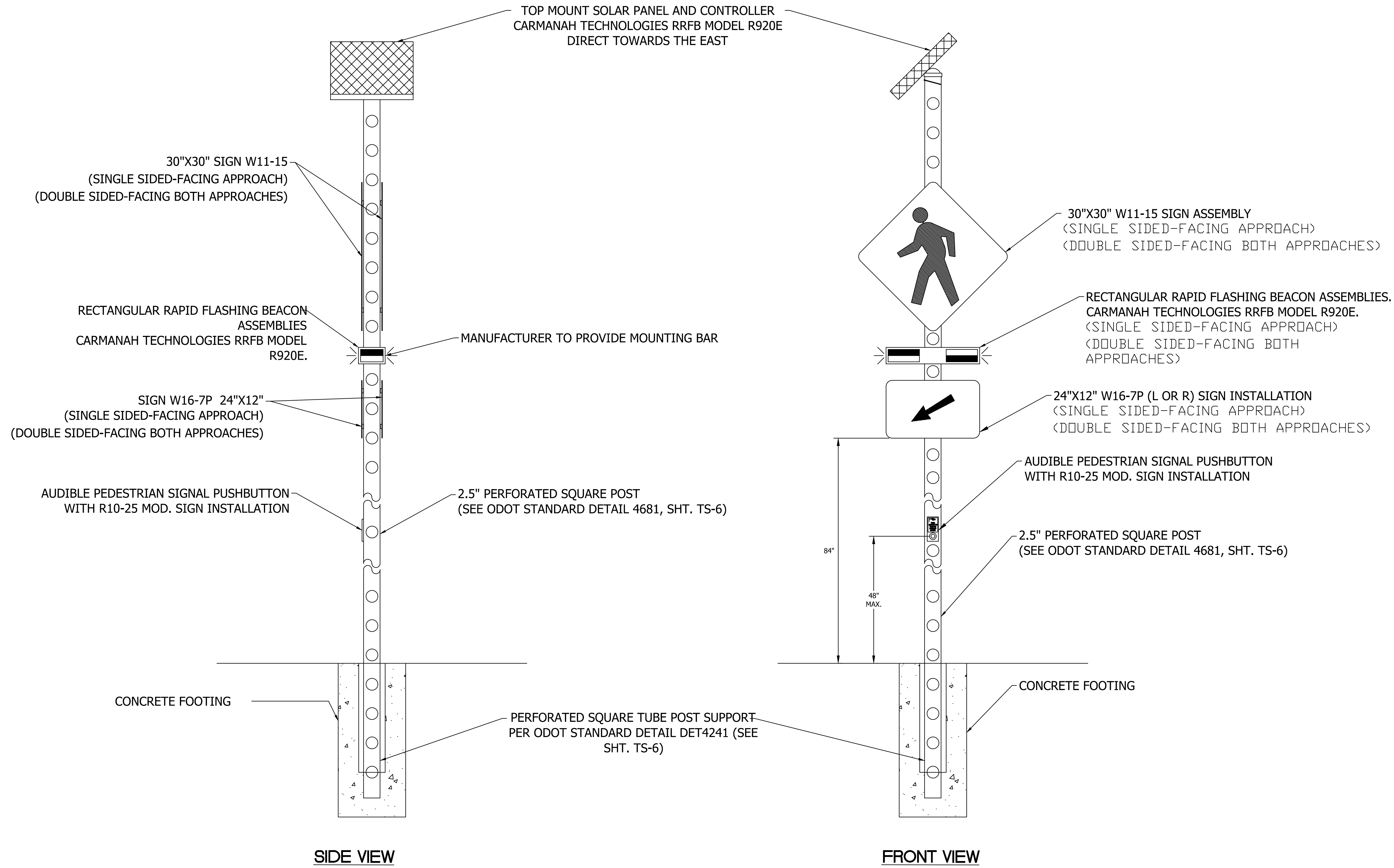

SIDE VIEW

FRONT VIEW

RECTANGULAR RAPID FLASHING DETAIL

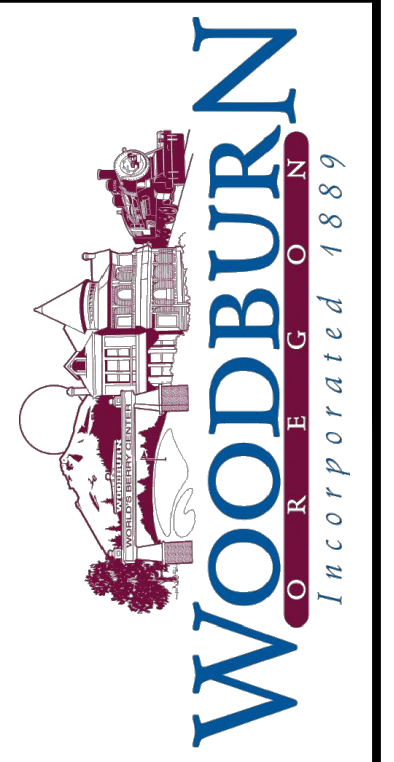

KITTELSON & ASSOCIATES
851 SW 6TH AVENUE, SUITE 600
PORTLAND, OR 97204
P 503.228.5230 F 503.273.8169

NO.	DATE	REVISION	APP'D.
01	05/25/22	ISSUE FOR CONSTRUCTION	FSW

Submission Date: 03/07/2022
Drawn: JBK
Designed: JBK
Checked: WES

PROJECT NO.
2015-001-20

W. Hayes Street Improvements
Cascade Avenue to Settlemier Avenue

SHEET NO.
TS-5

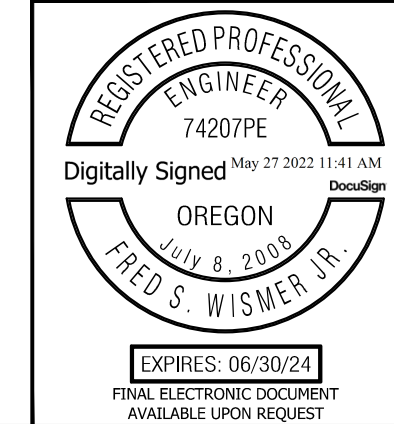

Plot Stamp: 5/25/2022 4:02:38 PM - Fred Wismer
File: H:\24\24512 - W. Hayes Street\design\CD\CD-Signal\Plans-24512.dwg

Plot Stamp: 5/25/2022 4:02:40 PM - Fred Wismer
 File: H:\24\24512 - W. Hayes Street\design\CD\CD-Signal\Plans-24512.dwg

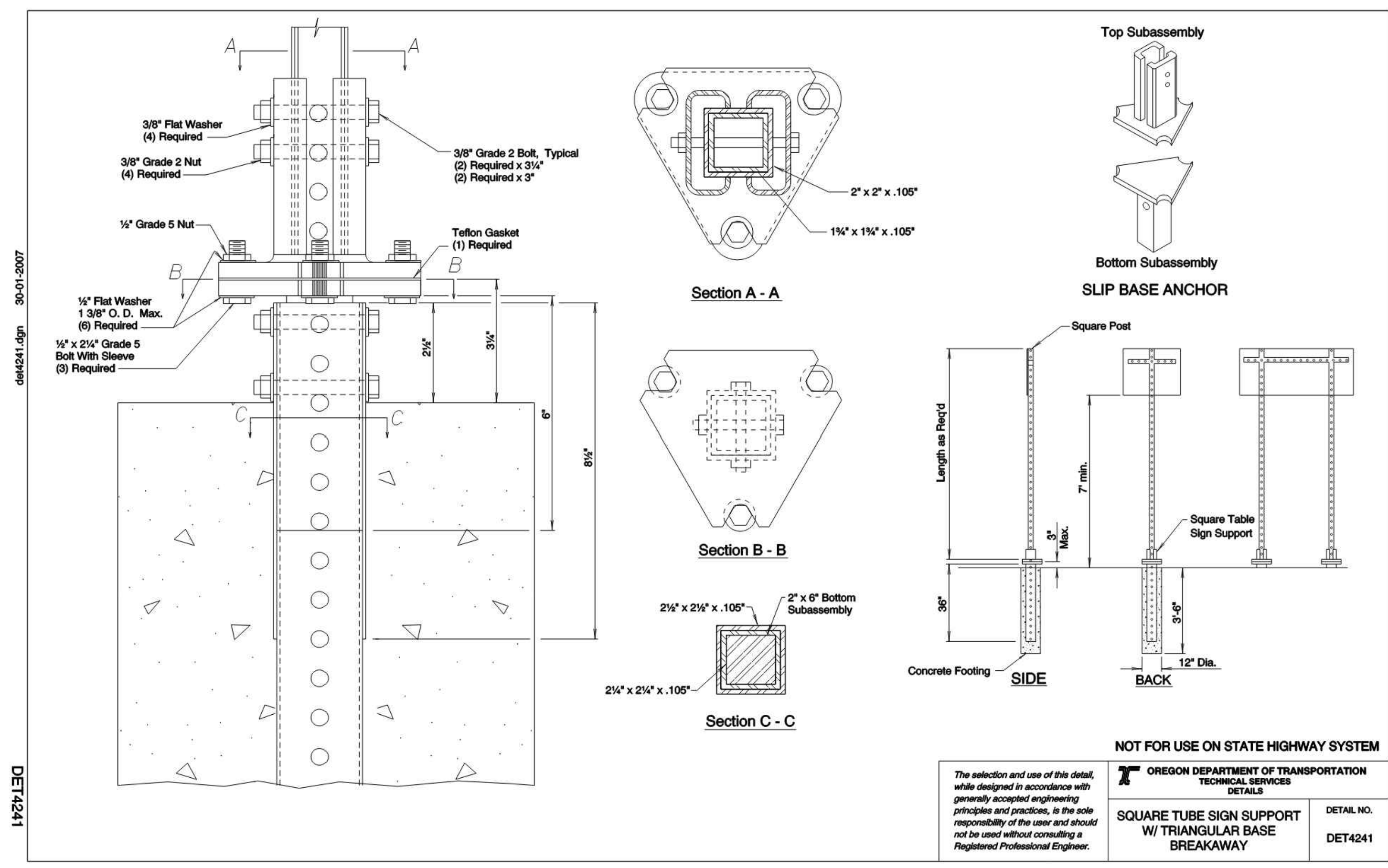

444241.dgn 30-10-10-2007

DET14241

OREGON DEPARTMENT OF TRANSPORTATION
 TECHNICAL SERVICES
 DETAILS
 SQUARE TUBE SIGN SUPPORT
 W/ TRIANGULAR BASE
 BREAKAWAY
 DETAIL NO.
 DET4241

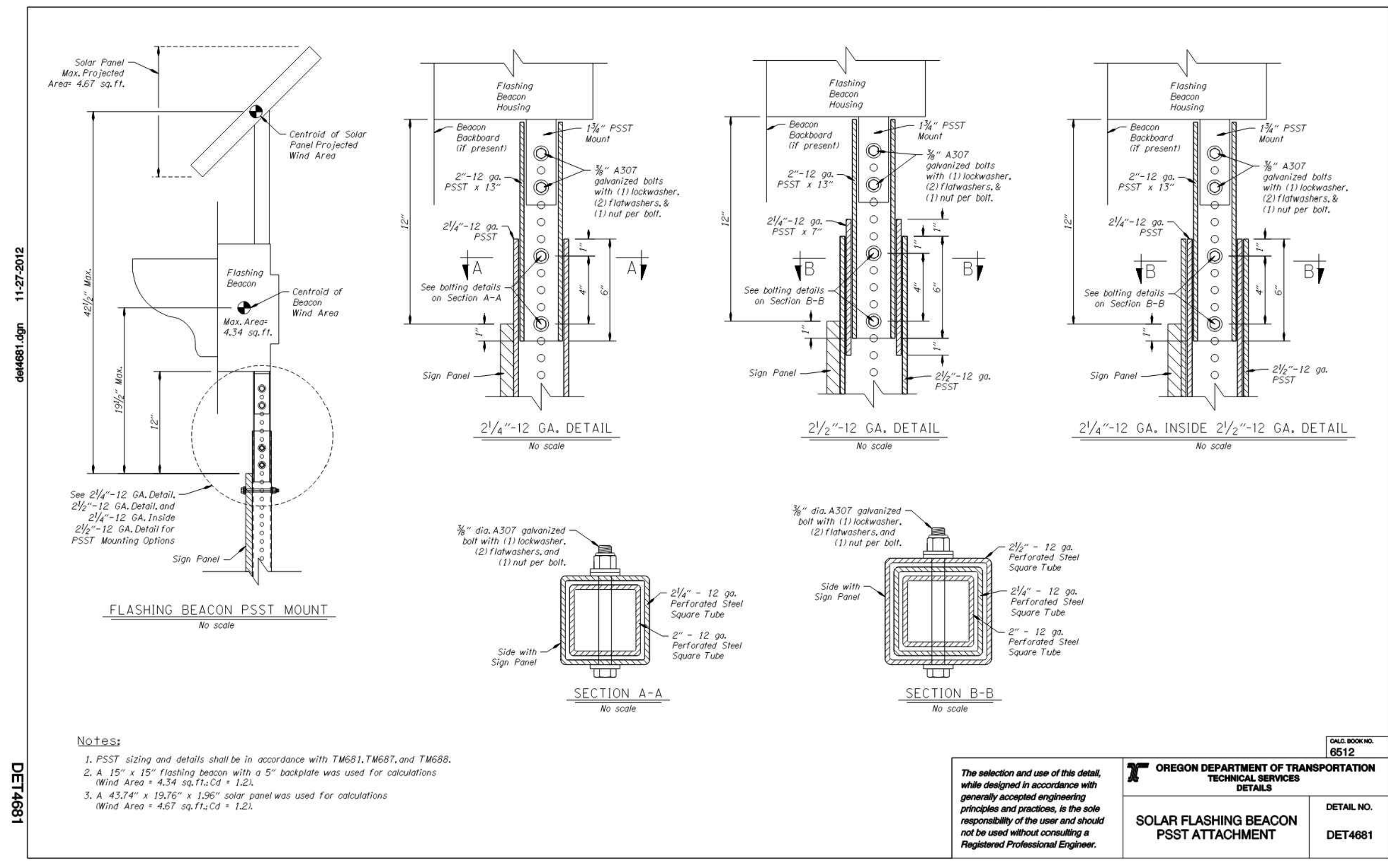

11-27-2012 dgp188989p

DET14691

OREGON DEPARTMENT OF TRANSPORTATION
 TECHNICAL SERVICES
 DETAILS
 SOLAR FLASHING BEACON
 PSST ATTACHMENT
 DETAIL NO.
 DET4691

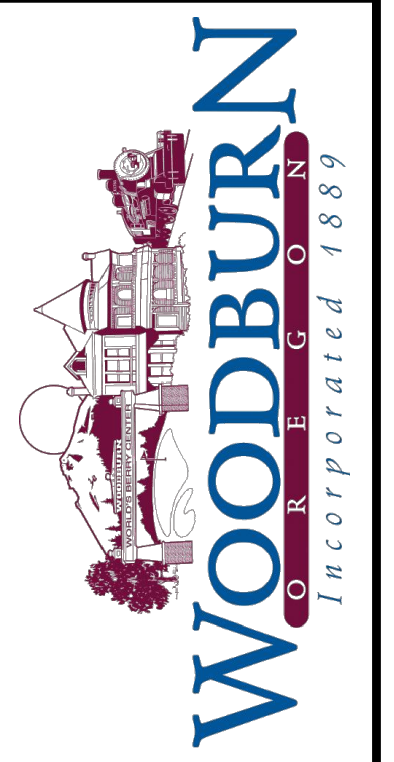
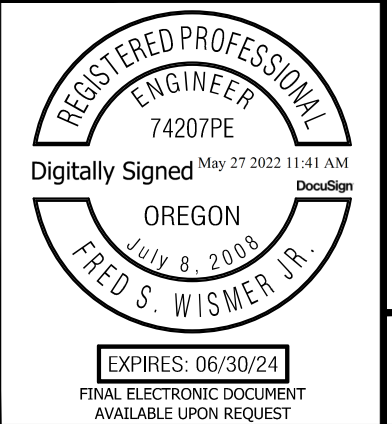

KITTELSON & ASSOCIATES
 851 SW 6TH AVENUE, SUITE 600
 PORTLAND, OR 97204
 P 503.228.5230 F 503.273.8169

NO.	REVISION	DATE	BY	APP'D.
0	ISSUE FOR CONSTRUCTION	05/25/22	JBK	FSW
	REVISION			APP'D.

Submission Date:
 03/07/2022
 Drawn: JBK
 Designed: JBK
 Checked: WES

PROJECT NO.
2015-001-20
W. Hayes Street Improvements
 Cascade Avenue to Settlemier Avenue
 SIGNAL DETAILS
 SHEET NO.
TS-6

Plot Stamp: 5/25/2022 4:10:40 PM - Fred Wismer
 File: H:\24\24512 - W. Hayes Street\design\CD\CD-Interconnect-24512.dwg

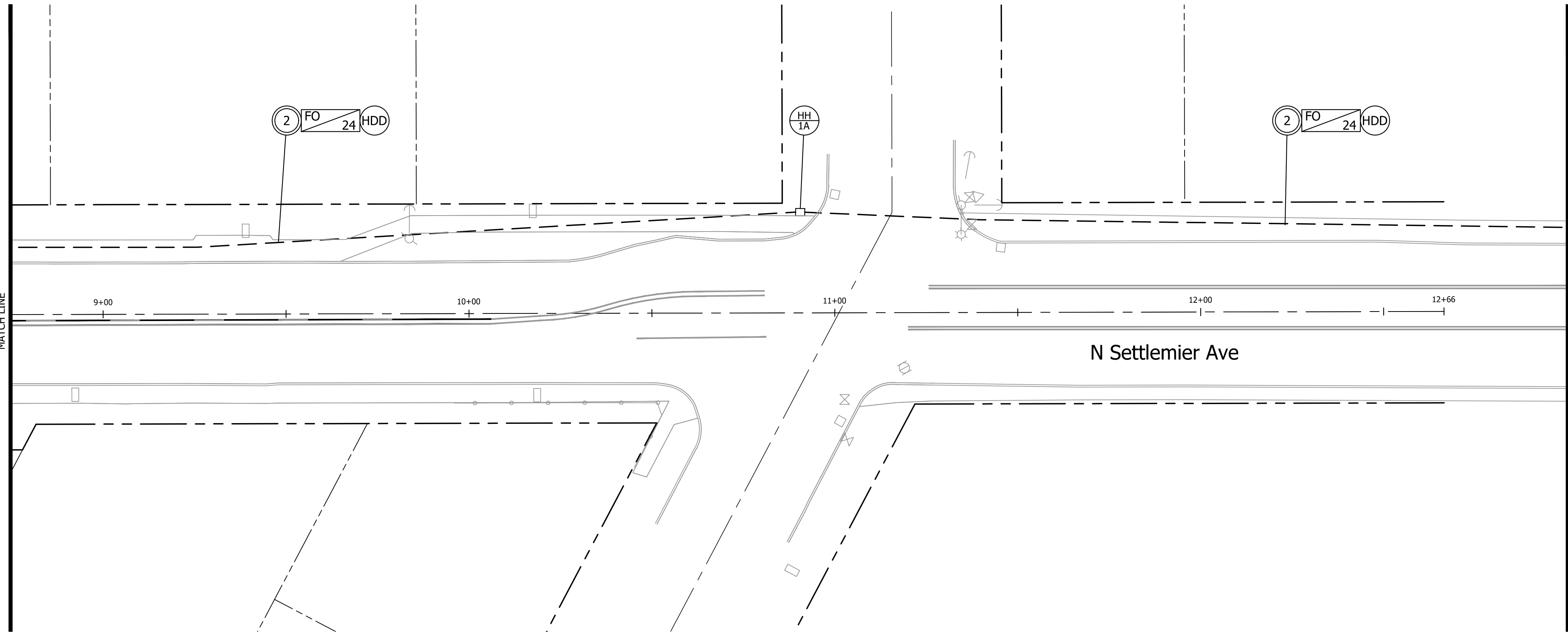
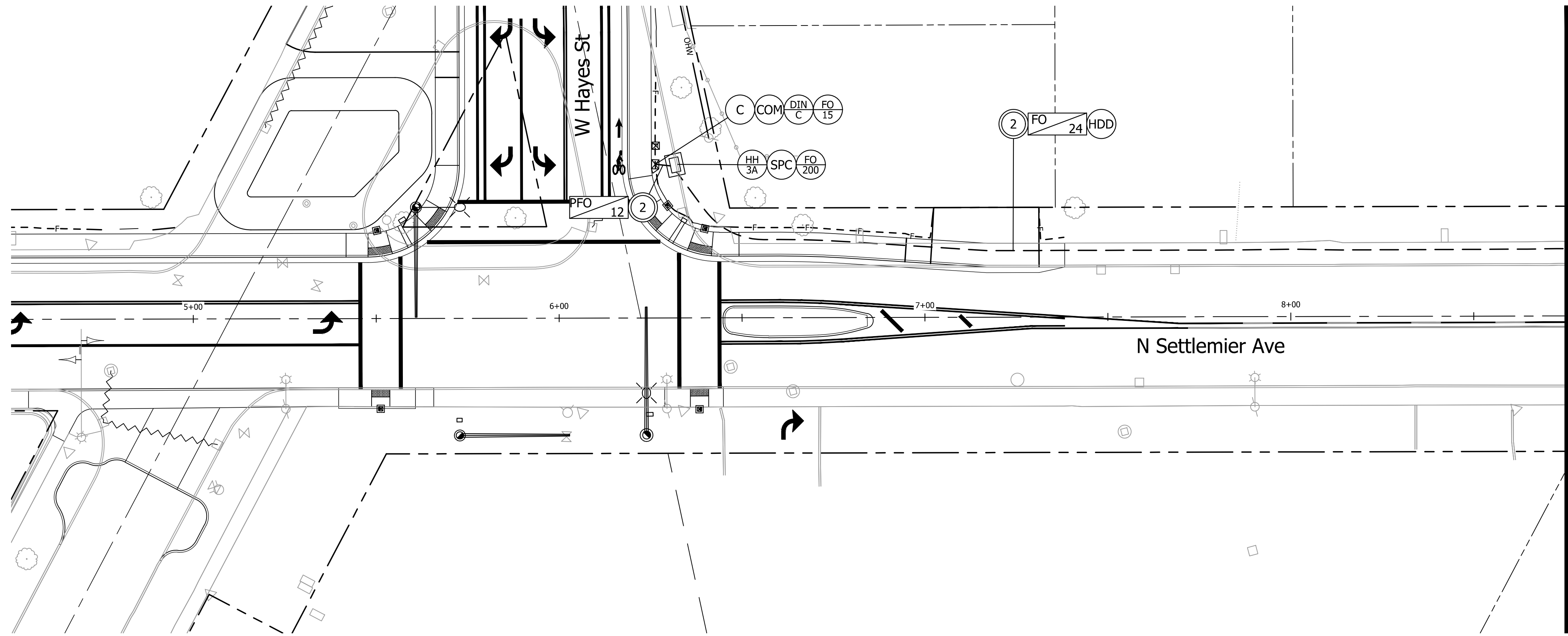

CONSTRUCTION NOTES

- (C) Controller cabinet
(See Signal Plan)
- FO N Install (N=number) strand single mode fiber optic cable. See Special Provisions.
- (HDD) Install conduit by horizontal direction drilling, open trench not allowed
- (HH 1A) Install 24"x30"x24" Fiber Optic Hand Hole w/ Concrete Apron (See TM472 for details)
- (HH 3A) Install 30"x48"x36" Fiber Optic Hand Hole w/ Concrete Apron (See TM472 for details)
- (2) Install (S=size) inch conduit
- PFO 12 Install (N=number) single mode fiber optic cable for fiber optic connection patch panel.
- (SPC) Install fiber optic splice closure.
- (COM) See sheet IC-3 for communications equipment to be furnished and installed.
- (DIN F) Install communications bracket for fiber optic interconnect.
Use only Green Sheet listed systems
- FO (N) Coil (N = number of feet) of fiber optic cable (in advance of splicing) in hand hole

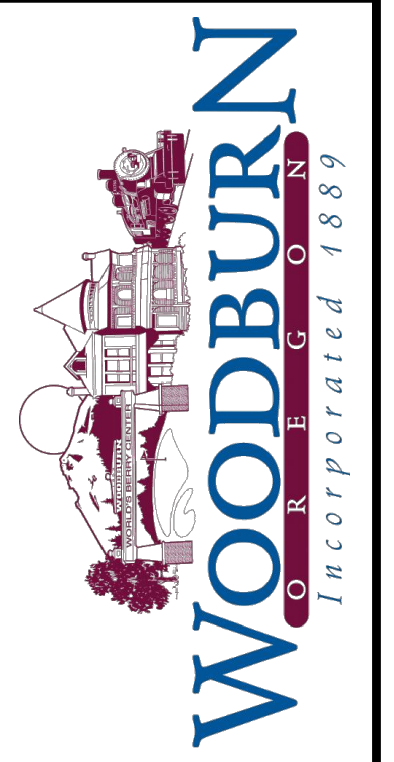
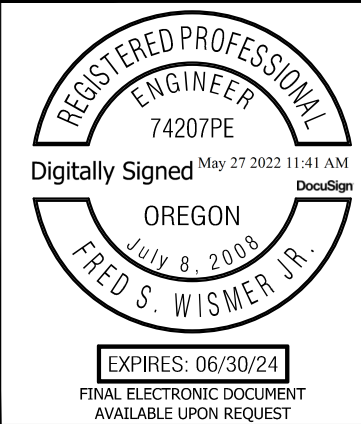
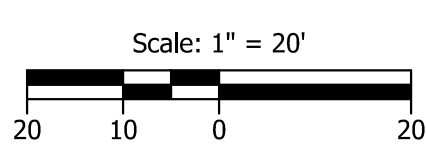
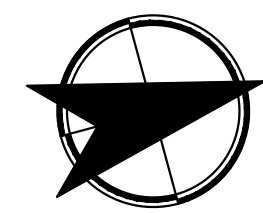

KITTELSON & ASSOCIATES
 851 SW 6TH AVENUE, SUITE 600
 PORTLAND, OR 97204
 P 503.228.5230 F 503.273.8169

ISSUE FOR CONSTRUCTION	DATE	REVISION	APP'D
0	05/25/22		FSW

Submission Date: 03/07/2022
 Drawn: JCB/RMM Designed: NRS/JBK Checked: FSW

PROJECT NO. 2015-001-20







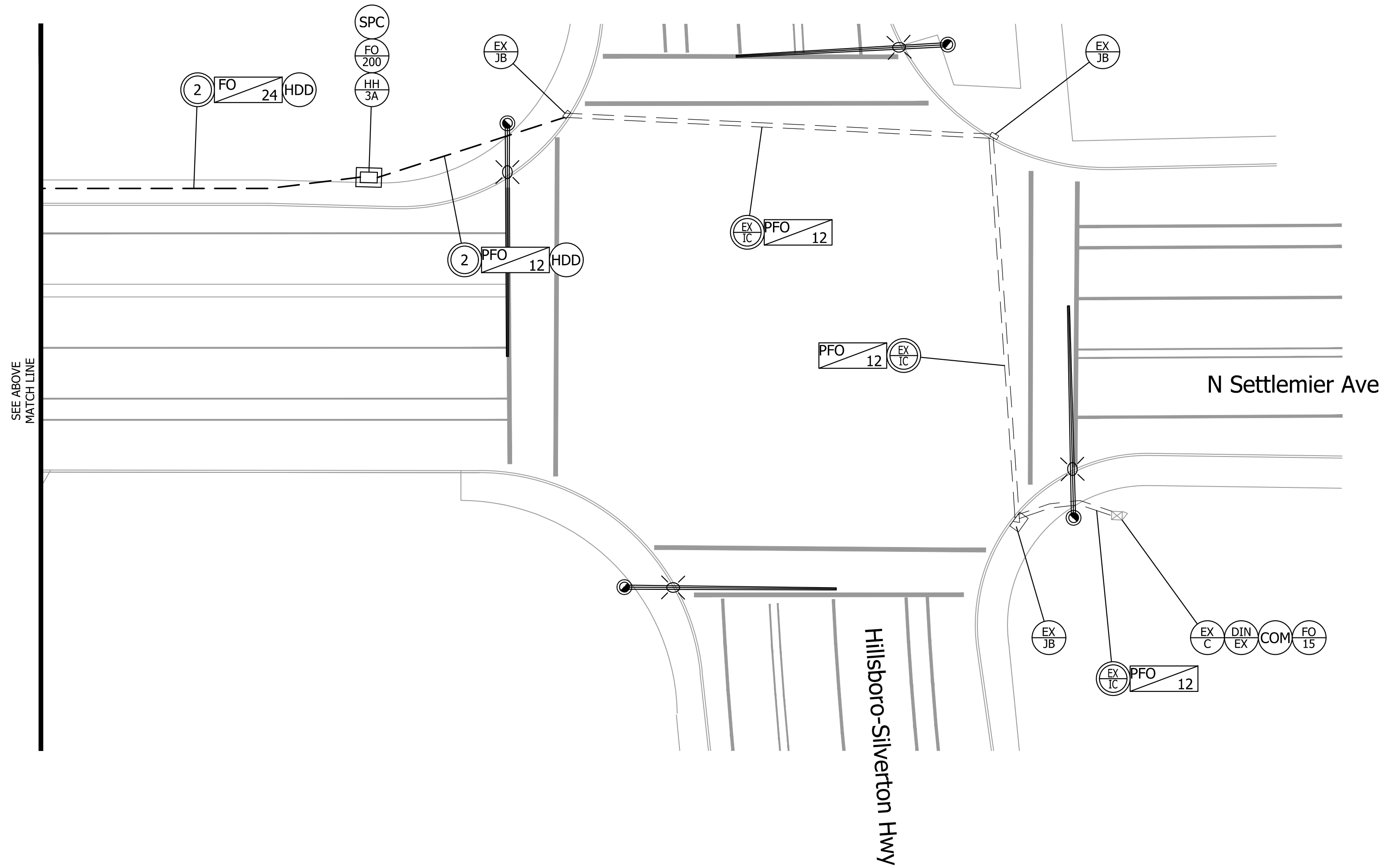
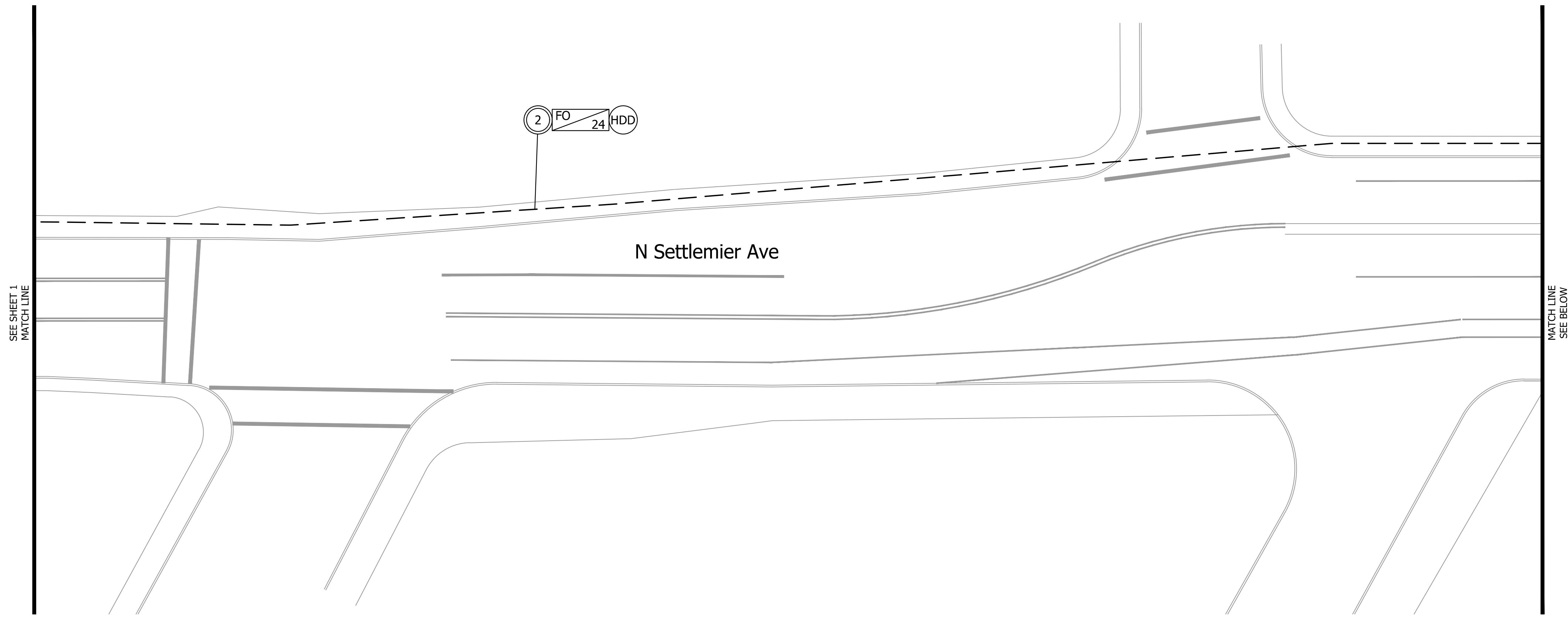

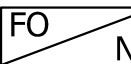

W. Hayes Street Improvements
 Cascade Avenue to Settlemier Avenue
 INTERCONNECT PLAN

SHEET NO. IC-1

Plot Stamp: 5/25/2022 4:10:46 PM - Fred Wismer
 File: H:\24\24512 - W. Hayes Street\design\CD\interconnect-24512.dwg

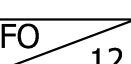

CONSTRUCTION NOTES

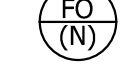
-  Install (N=number) strand single mode fiber optic cable. See Special Provisions.
-  Install conduit by horizontal direction drilling, open trench not allowed
-  Install 30"x48"x36" Fiber Optic Hand Hole w/ Concrete Apron (See TM472 for details)
-  Install (S=size) inch conduit
-  Retain and protect existing junction box
-  Retain and protect existing Model 170E/HC11 controller and Model 332 Cabinet
-  Retain and protect existing interconnect conduit
-  Install (N=number) single mode fiber optic cable for fiber optic connection patch panel.
-  Install fiber optic splice closure.
-  See sheet IC-3 for communications equipment to be furnished and installed.
-  Retain and protect existing communications bracket.
-  Coil (N = number of feet) of fiber optic cable (in advance of splicing) in hand hole

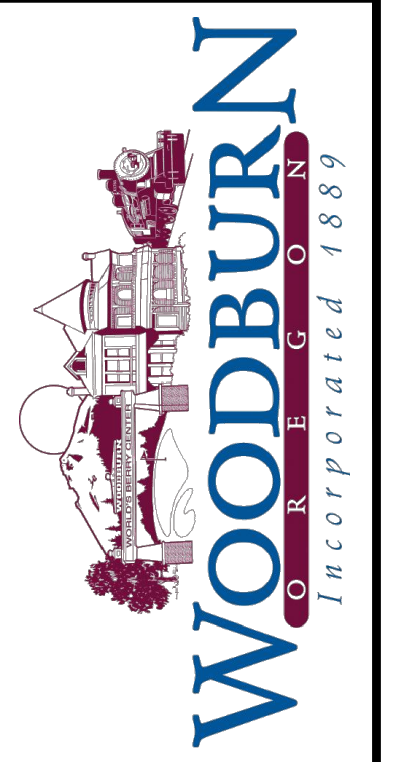
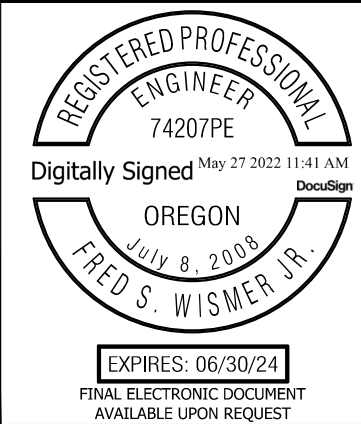
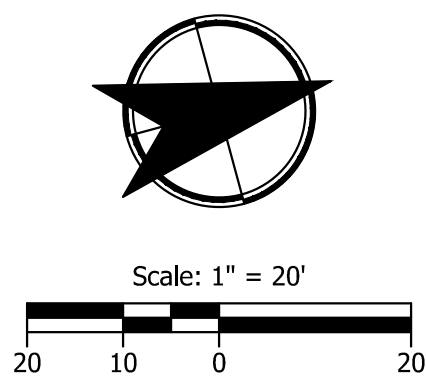

KITTELSON & ASSOCIATES
 851 SW 6TH AVENUE, SUITE 600
 PORTLAND, OR 97204
 P 503.228.5230 F 503.273.8169

DATE	REVISION	APP'D
01/05/25/22	ISSUE FOR CONSTRUCTION	FSW

Submission Date: 03/07/2022
 Drawn: JCB/RMM Designed: NRS/JBK Checked: FSW
 PROJECT NO. 2015-001-20

W. Hayes Street Improvements
 Cascade Avenue to Settlemier Avenue
 INTERCONNECT PLAN

SHEET NO. IC-2

COMMUNICATION COMPONENT SCHEDULE			
LOCATION:	COMMUNICATIONS COMPONENTS	QUANTITY	OPTIC CONNECTION(S) TYPE
SETTLEMIER AVE. / HILLSBORO-SILVERTON HWY (OR 214)	A) ETHERNET EDGE SWITCH RS900G* SIEMENS PART NO. 6GK6090-0GS23-0BA1-Z A05	1	-
	B) SIX-FOOT POWER CABLE WITHOUT LUGS (BARE-WIRE) (FOR RUGGEDCOM RS900G SWITCH) SIEMENS PART NO. 6GK6000-8BB00-0AA0	1	-
	C) EXISTING ETHERNET EDGE SWITCH	1	-
	D) INDUSTRIAL ETHERNET CABLE	1	-
	E) FIBER PATCH PANEL	1	-
	F) FIBER OPTIC PATCH CORD	2	-

* CONTRACTOR TO DELIVER SWITCH GEAR TO ODOT. ODOT WILL CONFIGURE AND INSTALL SWITCH GEAR.

COMMUNICATION COMPONENT SCHEDULE			
LOCATION:	COMMUNICATIONS COMPONENTS	QUANTITY	OPTIC CONNECTION(S) TYPE
HAYES ST. / SETTLEMIER AVE.	A) ETHERNET EDGE SWITCH RS900G* SIEMENS PART NO. 6GK6090-0GS23-0BA1-Z A05	1	-
	B) SIX-FOOT POWER CABLE WITHOUT LUGS (BARE-WIRE) (FOR RUGGEDCOM RS900G SWITCH) SIEMENS PART NO. 6GK6000-8BB00-0AA0	1	-
	C) INDUSTRIAL ETHERNET CABLE	1	-
	D) FIBER PATCH PANEL	1	-
	E) FIBER OPTIC PATCH CORD	1	-

* CONTRACTOR TO DELIVER SWITCH GEAR TO ODOT. ODOT WILL CONFIGURE AND INSTALL SWITCH GEAR.

HAYES ST. / SETTLEMIER AVE.
NEW SIGNAL CABINET

SETTLEMIER AVE. / HILLSBORO-SILVERTON HWY (OR 214)
EXISTING SIGNAL CABINET

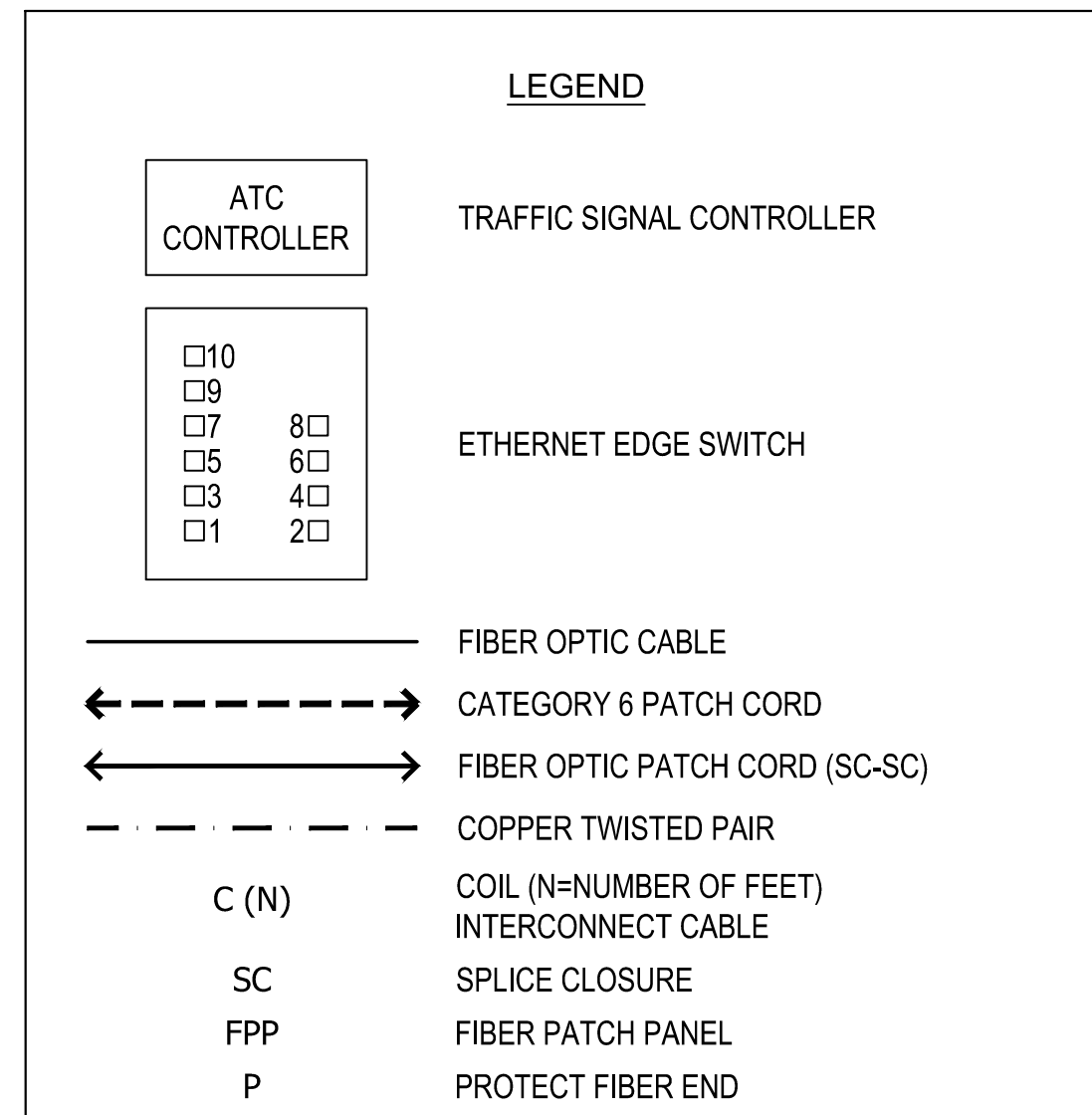
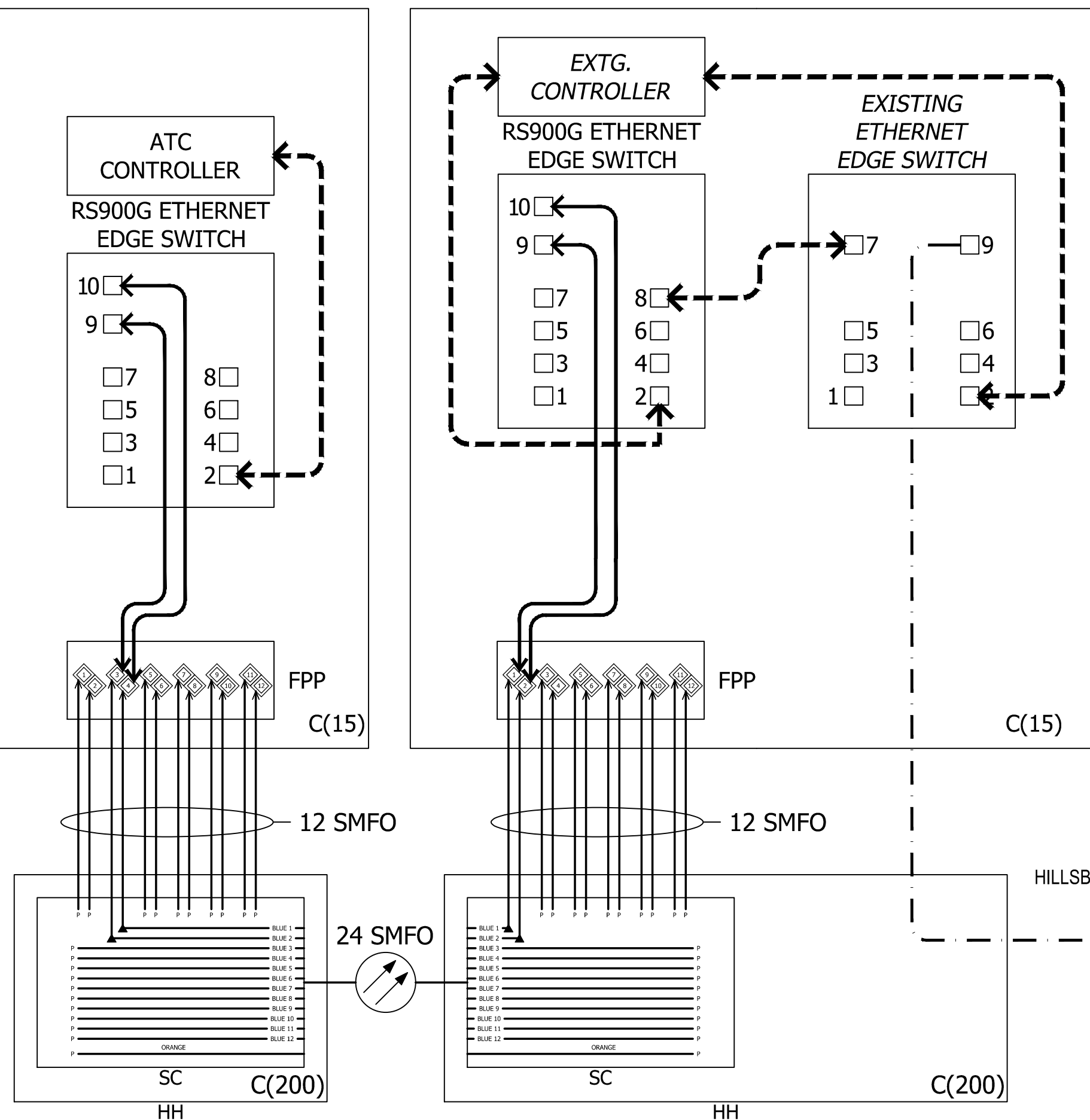

GENERAL NOTES:

- This drawing provides a schematic of the communications system only. Not all junction boxes are shown on this plan.
- Fiber optic cable shall be continuous.

TYPICAL CABINET LAYOUT - TYPE 332 STRETCH

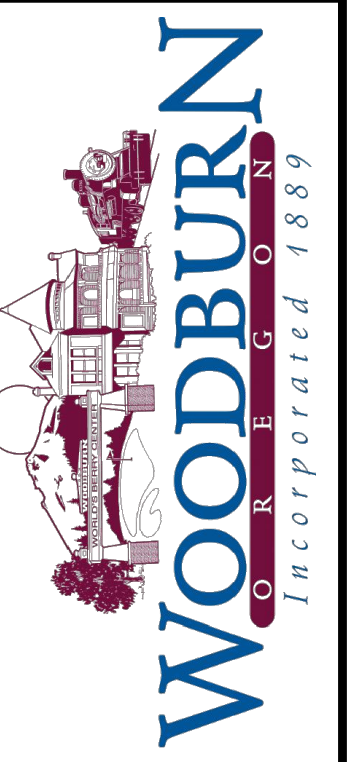
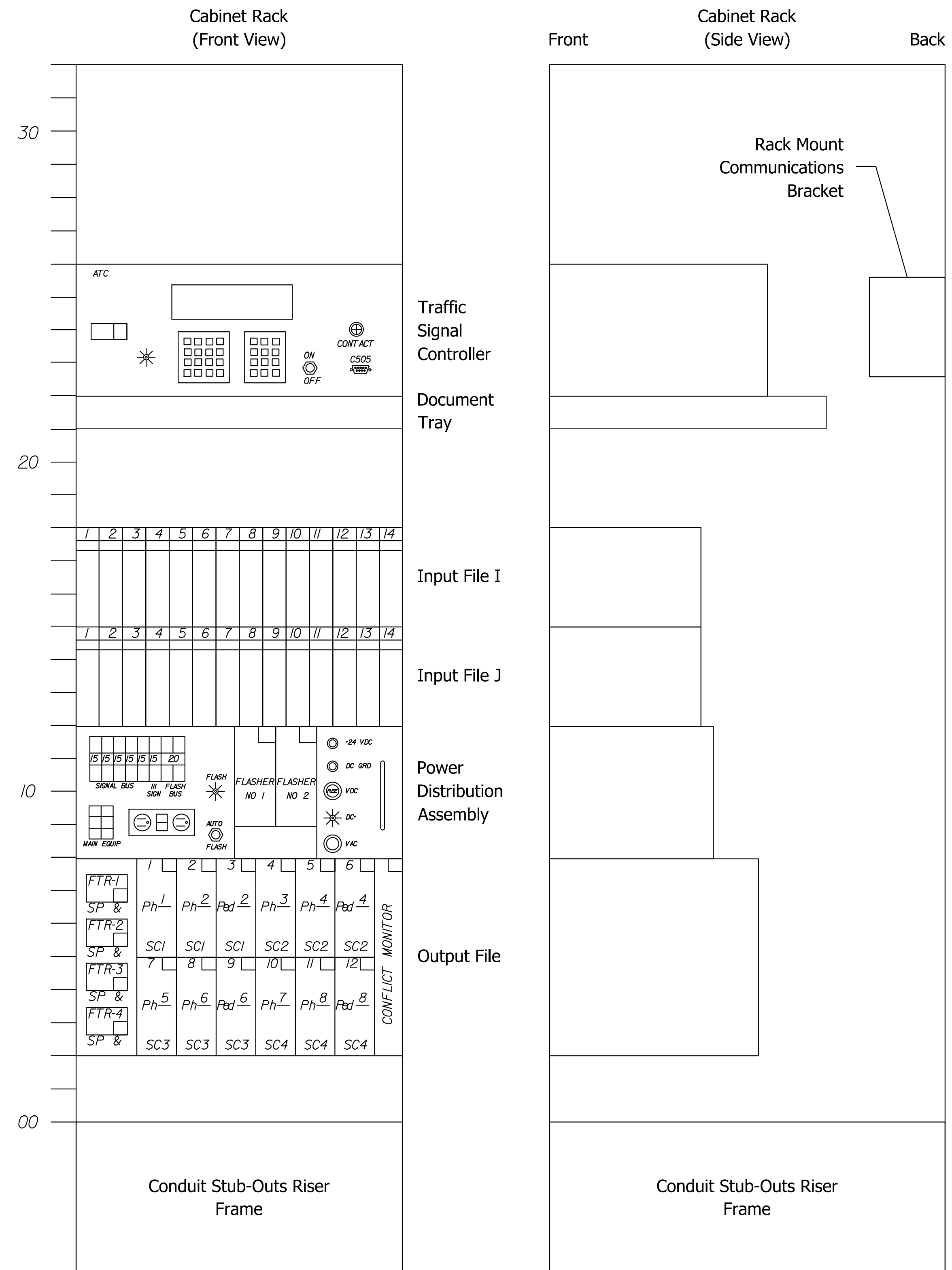

KITTELSON & ASSOCIATES
851 SW 6TH AVENUE, SUITE 600
PORTLAND, OR 97204
P 503.228.5230 F 503.273.8169

NO.	DATE	REVISION	BY	APP'D.
0	05/25/22	ISSUE FOR CONSTRUCTION	FSW	APP'D.

Submission Date: 03/07/2022
Drawn: JCB/RMM
Designed: NRS/JBK
Checked: FSW

PROJECT NO. 2015-001-20

W. Hayes Street Improvements
Cascade Avenue to Settlemier Avenue

INTERCONNECT DETAILS

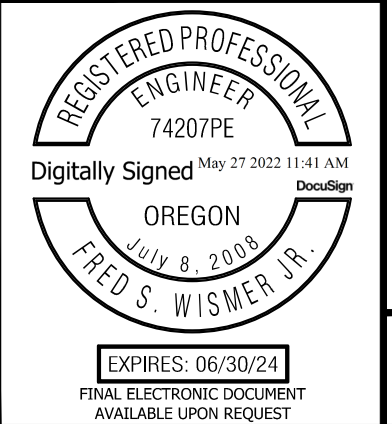

SHEET NO. IC-3

ILLUMINATION LEGEND

- PRESERVE & PROTECT EXISTING UTILITY POLE (UP).
- EXISTING LIGHT POLE AND LUMINAIRE.
- EXISTING LUMINAIRE.
- REMOVE EXISTING LUMINAIRE. CONTRACTOR TO COORDINATE WITH PGE.
- INSTALL LUMINAIRE LIGHT POLE (LP), POLE NUMBER (N).
- INSTALL LEOTEK GCM2-40H-MV-WW-2R-GY-700-PCR7 LED LUMINAIRE BY PGE.
- INSTALL PHOTOELECTRIC CONTROL BY PGE.
- JOINT USE TRAFFIC SIGNAL/ ILLUMINATION POLE (N=SIGNAL POLE NUMBER) (SEE POLE ENTRANCE CHART AND TRAFFIC SIGNAL PLAN).
- INSTALL (S=SIZE) INCH CONDUIT.
- INSTALL 17"X30"X18" (MIN. DIMENSION) PRECAST CONCRETE JUNCTION BOX WITH CONCRETE APRON.

APPROVED STREET LIGHTING EQUIPMENT:

- COBRA STYLE LIGHT POLE SHALL BE ALUMINUM FIXED SMOOTH BASE. THE APPROVED POLES ARE:

MANUFACTURER:	CATALOG NUMBER:
VALMONT	250075105D4
HAPCO	41-103PGE
P&K POLES (FLAGPOLE INC)	RTA7L25AAD1432D
- ANCHOR POLE FOOTING SHALL BE PGE APPROVED PRE-CAST CONCRETE.

MANUFACTURER:	CATALOG NUMBER:
UTILITY VAULT COMPANY	5CL-LB-PGE
- JUNCTION BOXES SHALL BE CITY APPROVED SPLICE BOXES. CITY APPROVED BOXES ARE:

MANUFACTURER:	CATALOG NUMBER:
QUAZITE (HUBBEL) - 17" X 30" X 18" (90003480)	A42173018A017
NEWBASIS - 17" X 30" X 18" (90003480)	FCA173018T-90026
QUAZITE (HUBBELL) - 17" X 30" X 18" (90003480)	A42173018A017
OLDCASTLE / CARSON INDUSTRIES - 17" X 30" X 18" (90003480)	17301726
CDR (ELECTRIMOLD) - 17" X 30" X 18" (90003480)	
HIGHLINE - 17" X 30" X 18" (90003480)	CHA173018HE1
ARMORCAST - 17" X 30" X 18" (90003480)	A6001640TAX18-PGE
- DIMMABLE LED COBRA HEAD LUMINAIRES SHALL INCLUDE: WHITE LEDS WITH CLEAR PLASTIC OPTICS BELOW EACH, NOMINAL COLOR TEMPERATURE OF 4000K. LIGHT DISTRIBUTION AND DRIVE CURRENT AS SPECIFIED. THE LUMINAIRES SHALL BE:

MANUFACTURER:	CATALOG NUMBER:
LEOTEK	GCM2-40H-MV-WW-2R-GY-700-PCR7-RWG-WL-FDC-PGE
- THE PHOTOELECTRIC CONTROL SHALL BE PGE APPROVED PHOTOCELL PER PGE APPROVED STREET LIGHTING EQUIPMENT.

GENERAL NOTES

- STREET LIGHTS ARE SCHEDULE 95 OPTION B EXCEPT AS NOTED ON THE PLANS AND SHALL BE CONTROLLED BY THE PHOTOELECTRIC CONTROL.
- ALL WORK DONE ON UTILITY POLES SHALL BE PERFORMED BY PGE.
- ALL MATERIALS AND WORKMANSHIP OF THE ILLUMINATION SYSTEM SHALL CONFORM TO PGE SPECIFICATIONS, THE SPECIAL PROVISIONS, AND THE 2021 OREGON STANDARD SPECIFICATIONS FOR CONSTRUCTION. ALL MATERIALS SHALL BE APPROVED BY CITY OF WOODBURN
- ALL ELECTRICAL EQUIPMENT SHALL CONFORM TO THE CURRENT STANDARDS OF THE NATIONAL ELECTRICAL MANUFACTURERS ASSOCIATION (NEMA) AND THE UNDERWRITERS LABORATORIES, INC. (U.L.) WHEREVER APPLICABLE. IN ADDITION TO THE REQUIREMENTS OF THE PLANS, STANDARD SPECIFICATIONS, AND THE SPECIAL PROVISIONS, ALL MATERIALS AND WORKMANSHIP SHALL CONFORM TO THE CURRENT REQUIREMENTS OF THE NATIONAL ELECTRICAL CODE (NEC) THE NATIONAL ELECTRICAL SAFETY CODE, STANDARDS OF THE AMERICAN NATIONAL STANDARDS INSTITUTE (ANSI), AND ANY LOCAL ORDINANCES WHICH MAY APPLY.
- LOCATION OF ILLUMINATION CONDUITS AND JUNCTION BOXES ARE APPROXIMATE. COORDINATE WITH OTHER UTILITIES TO ENSURE PROPER INSTALLATION.
- ALL JUNCTION BOXES NOT INSTALLED IN THE SIDEWALK SHALL HAVE A CONCRETE APRON PER OREGON STANDARD DRAWING TM472.
- CONTRACTOR SHALL COORDINATE WIRING INSTALLATION WITH _____ AT (###) ###-#### WITH PGE AND JOB NUMBER M _____.

INTERSECTION LIGHT LEVEL SUMMARY TABLE

INTERSECTION	CLASSIFICATION (PEDESTRIAN CATEGORY)		AVERAGE LIGHT LEVEL (FC)	UNIFORMITY (AVE:MIN)
W Hayes Street/ Cascade Drive	COLLECTOR/LOCAL (LOW)	RECOMMENDED	0.9	4.0:1
		DESIGN	0.9	4.7:1*
W Hayes Street/ Killian Springs	COLLECTOR/LOCAL (LOW)	RECOMMENDED	0.9	4.0:1
		DESIGN	0.9	2.8:1
W Hayes Street/ Cozy Way	COLLECTOR/LOCAL (LOW)	RECOMMENDED	0.9	4.0:1
		DESIGN	1.3	4.2:1*
W Hayes Street/ Smith Drive	COLLECTOR/LOCAL (LOW)	RECOMMENDED	0.9	4.0:1
		DESIGN	0.9	4.2:1*
W Hayes Street/ Leasure St	COLLECTOR/LOCAL (LOW)	RECOMMENDED	0.9	4.0:1
		DESIGN	0.9	4.3:1*
W Hayes Street/ Hall Street	COLLECTOR/LOCAL (LOW)	RECOMMENDED	0.9	4.0:1
		DESIGN	1.1	3.6:1
W Hayes Street/ N Settlemier Avenue	COLLECTOR/ARTERIAL (MEDIUM)	RECOMMENDED	2.0	3.0:1
		DESIGN	2.0	2.5:1

*Average light and uniformity levels are not met due to the spacing of the existing street lights

ROAD SEGMENT LIGHT LEVEL SUMMARY TABLE

SEGMENT	CLASSIFICATION (PEDESTRIAN CATEGORY)		AVERAGE LIGHT LEVEL (fc)	UNIFORMITY (AVE:MIN)
CASCADE DRIVE TO KILLIAN SPRINGS	COLLECTOR (LOW)	RECOMMENDED	0.4	8.0:1
		DESIGN	1.1	5.5:1
KILLIAN SPRINGS TO COZY WAY	COLLECTOR (LOW)	RECOMMENDED	0.4	8.0:1
		DESIGN	0.8	8.1:1*
COZY WAY TO SMITH DRIVE	COLLECTOR (LOW)	RECOMMENDED	0.4	8.0:1
		DESIGN	0.8	4.0:1
SMITH DRIVE TO LEASURE STREET	COLLECTOR (LOW)	RECOMMENDED	0.4	8.0:1
		DESIGN	1.0	2.6:1
LEASURE STREET TO HALL STREET	COLLECTOR (LOW)	RECOMMENDED	0.4	8.0:1
		DESIGN	1.2	3.0:1
HALL STREET TO SETTLEMIER AVENUE	COLLECTOR (LOW)	RECOMMENDED	0.4	8.0:1
		DESIGN	1.1	2.2:1

*Average and uniformity levels are not met due to the spacing of the existing street lights

PEDESTRIAN CROSSING LIGHT LEVEL SUMMARY TABLE

SEGMENT	ROADWAY CLASSIFICATION		AVERAGE LIGHT LEVEL (FC)	UNIFORMITY (AVE:MIN)	MIN VERTICAL LIGHT LEVEL (FC)
MID BLOCK CROSSING	LOCAL (LOW)	RECOMMENDED	0.4	4.0:1	0.1
		DESIGN	0.8	1.2:1	0.7

LIGHT POLE LOCATION TABLE

POLE NO.	LUM. TYPE	STREET	STATION	OFFSET	MOUNTING HEIGHT	WATTAGE	PGE SCHEDULE AND OPTION
1	CU 1369	W HAYES ST	14+39.84	29.01	25	88	95 B
2	CU 1369	W HAYES ST	15+80.71	41.00	25	88	95 B
3	CU 1369	W HAYES ST	17+10.74	41.00	25	88	95 B
4	CU 1369	W HAYES ST	18+40.78	41.00	25	88	95 B
5	CU 1369	W HAYES ST	19+70.01	41.00	25	88	95 B
6	CU 1369	W HAYES ST	21+31.00	41.00	25	88	95 B
7	CU 1369	W HAYES ST	37+77.62	27.58	25	88	95 B

LUMINAIRE SCHEDULE

QTY	TYPE DISTRIBUTION WATTAGE	INITIAL LUMEN	LLF	BUG RATING
7	LEOTEK GreenCobra H-Series, TYPE II, 700mA, 88W	10,230	0.85	B2-U0-G2

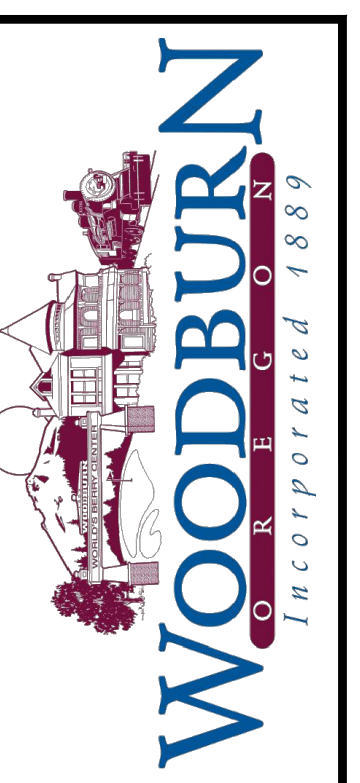
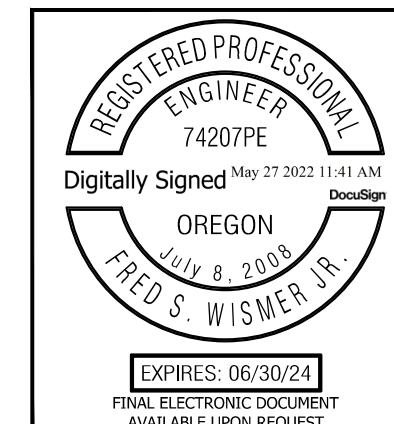
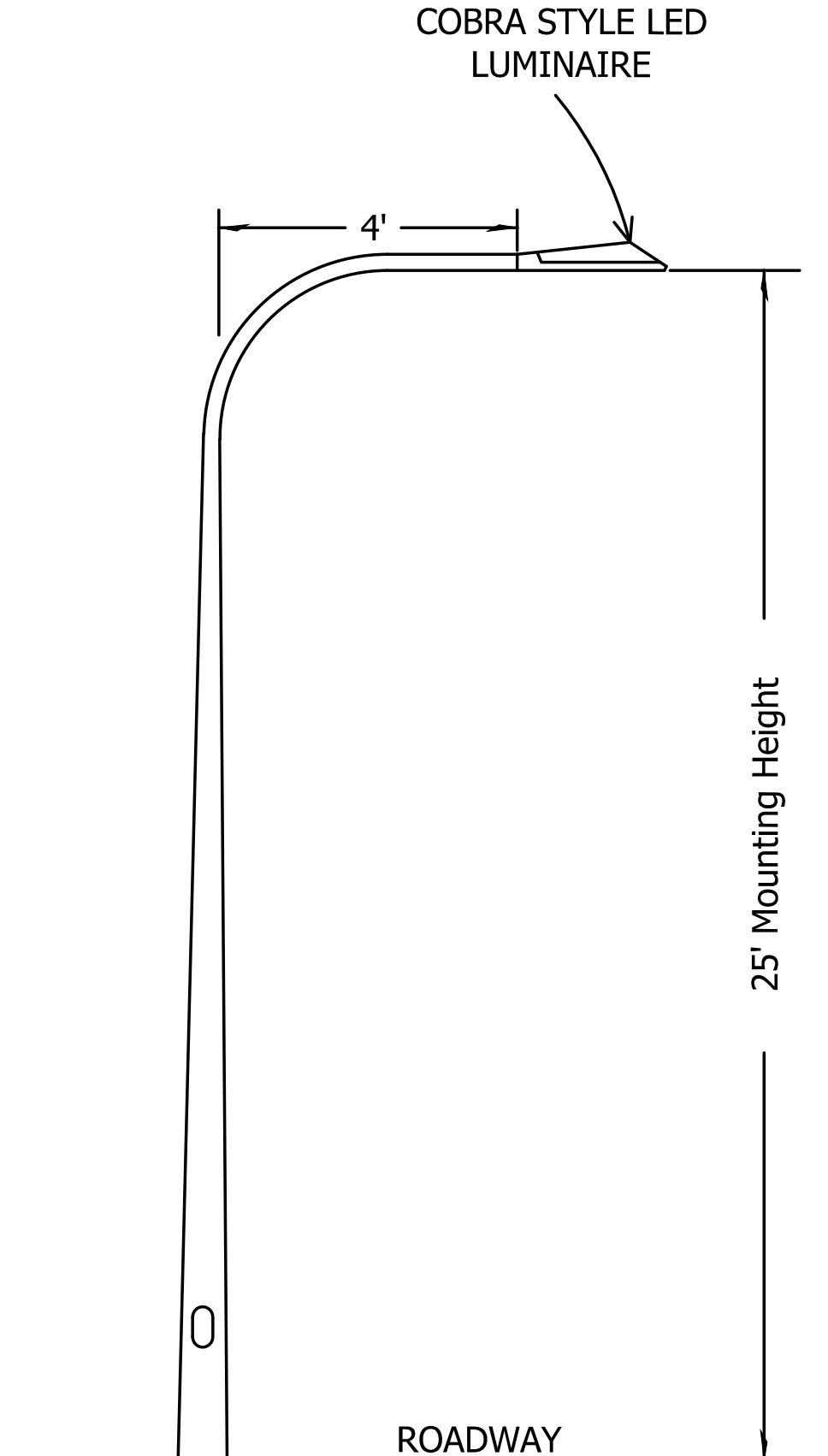
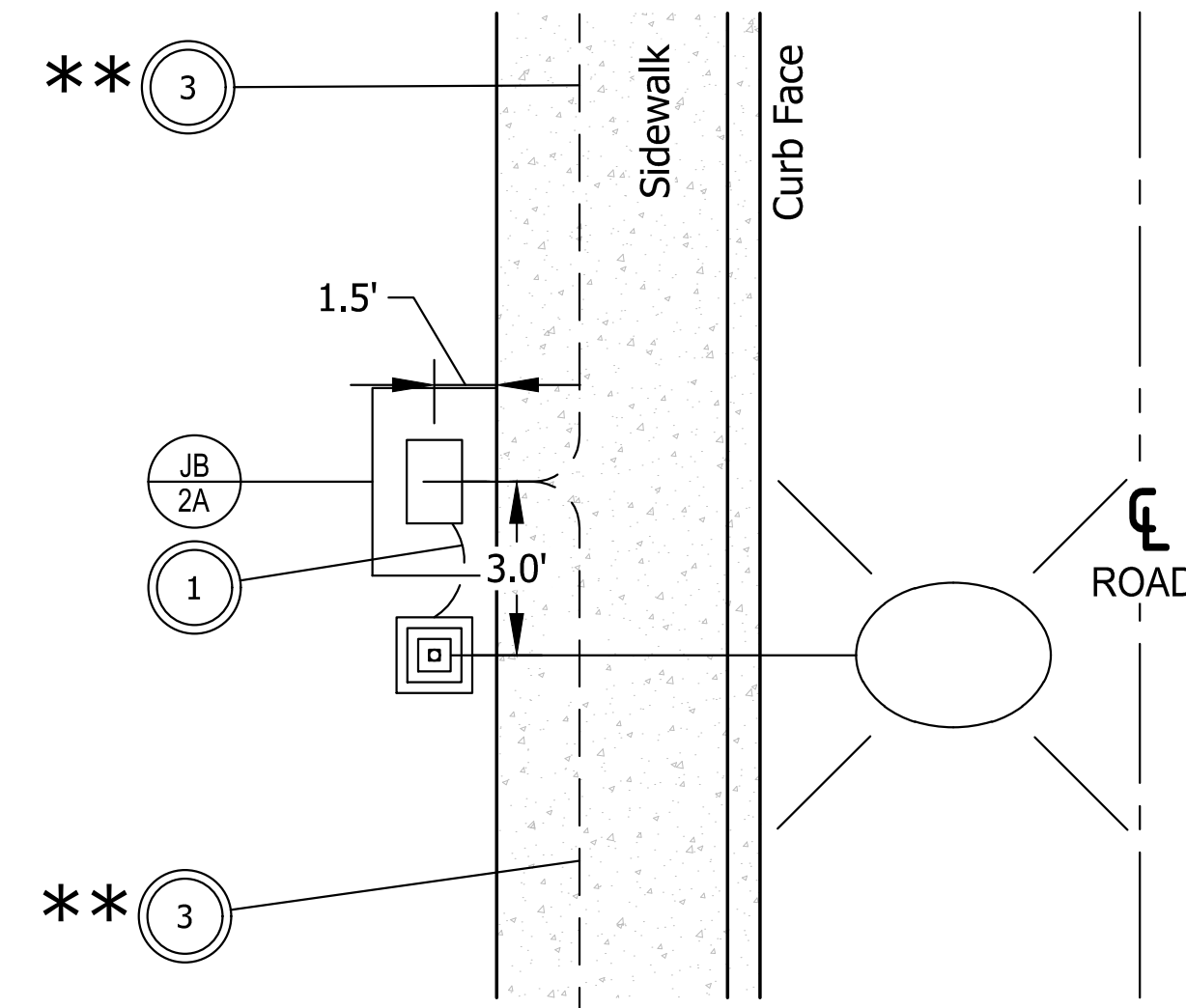

REVISION	DATE	ISSUE FOR CONSTRUCTION	APPROVED
0	05/25/22	ISSUE FOR CONSTRUCTION	FSW

Submission Date: 03/07/2022
 Drawn: JCB/RMM, Designed: NRS/JBK, Checked: FSW
 PROJECT NO. 2015-001-20

W. Hayes Street Improvements
 Cascade Avenue to Settlemier Avenue
 ILLUMINATION LEGEND AND NOTES

Plot Stamp: 5/25/2022 4:02:43 PM - Fred Wismer
 File: H:\24\24512 - W. Hayes Street\design\CD\CD-Illumination-24512.dwg

Plot Stamp: 5/27/2022 11:39:24 AM - Fred Wismer
 File: H:\24\24512 - W. Hayes Street\design\CD\CD-Illumination-24512.dwg

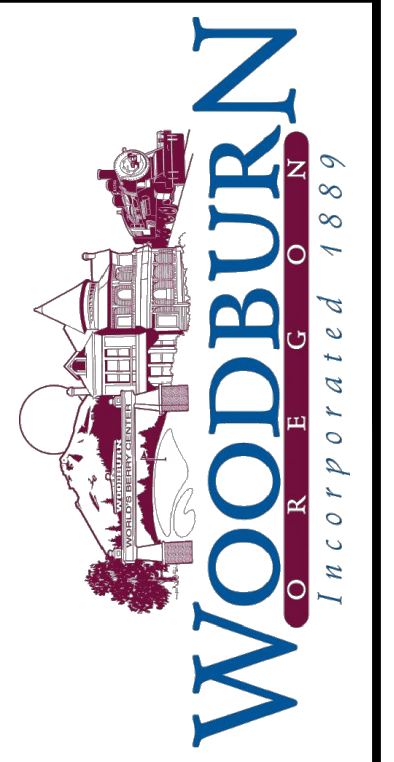
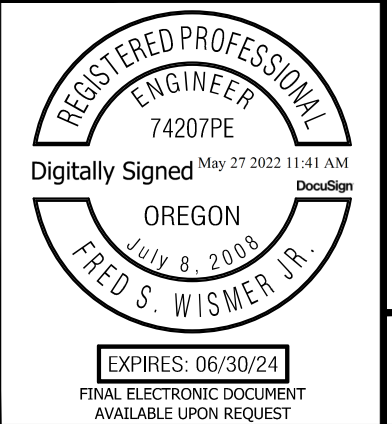
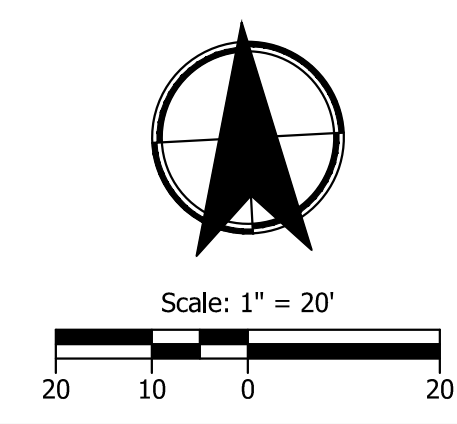
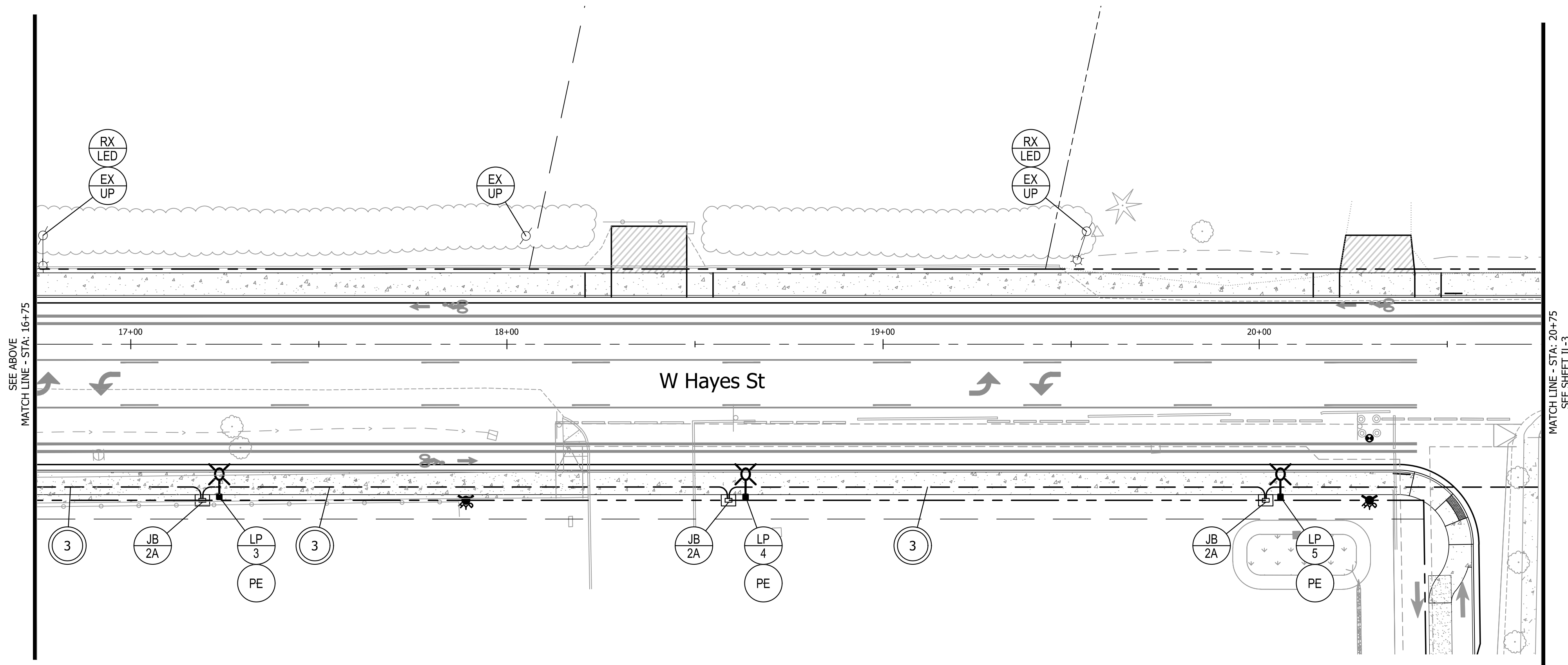
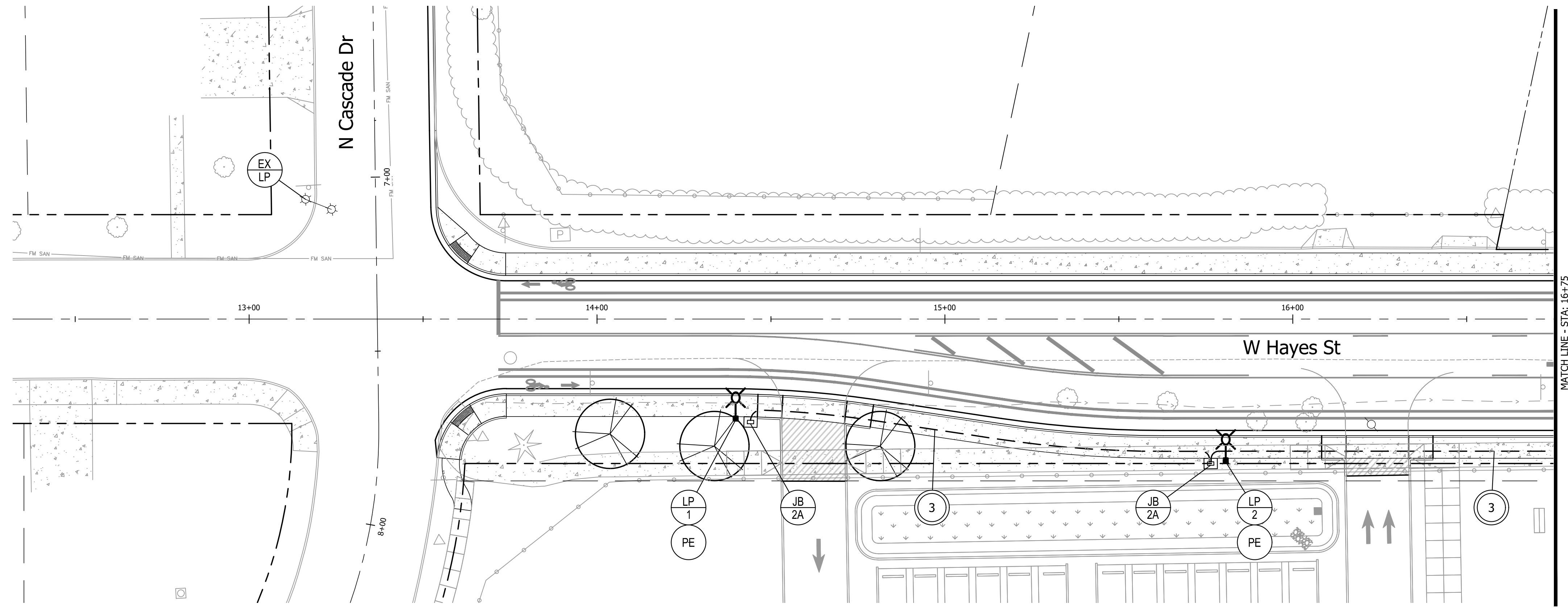

KITTELSON & ASSOCIATES
 851 SW 6TH AVENUE, SUITE 600
 PORTLAND, OR 97204
 P 503.228.5230 F 503.273.8169

#	DATE	REVISION	APP'D
0	05/25/22	ISSUE FOR CONSTRUCTION	FSW

Submission Date: 03/07/2022
 Drawn: JCB/RMM
 Designed: NRS/JBK
 Checked: FSW

PROJECT NO. 2015-001-20

W. Hayes Street Improvements
 Cascade Avenue to Settlemier Avenue
 ILLUMINATION PLAN

SHEET NO. IL-2

Plot Stamp: 5/27/2022 11:39:31 AM - Fred Wismer
 File: H:\24\24512 - W. Hayes Street\design\CD\CD-Illumination-24512.dwg

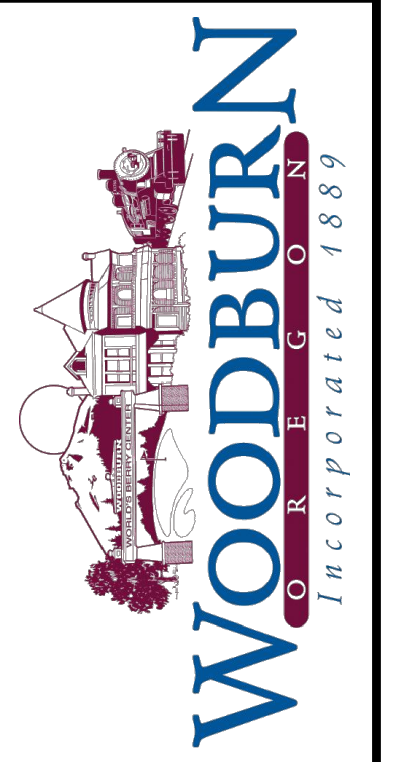
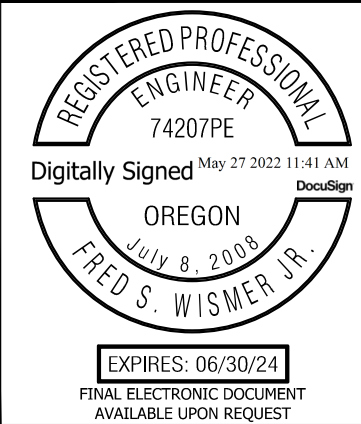
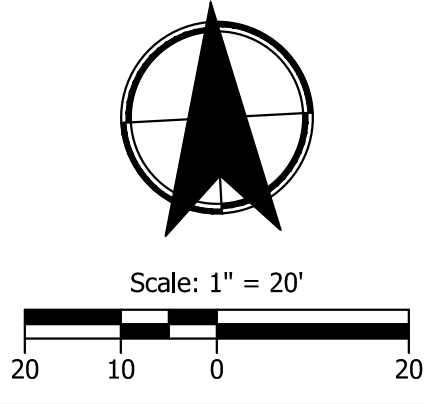
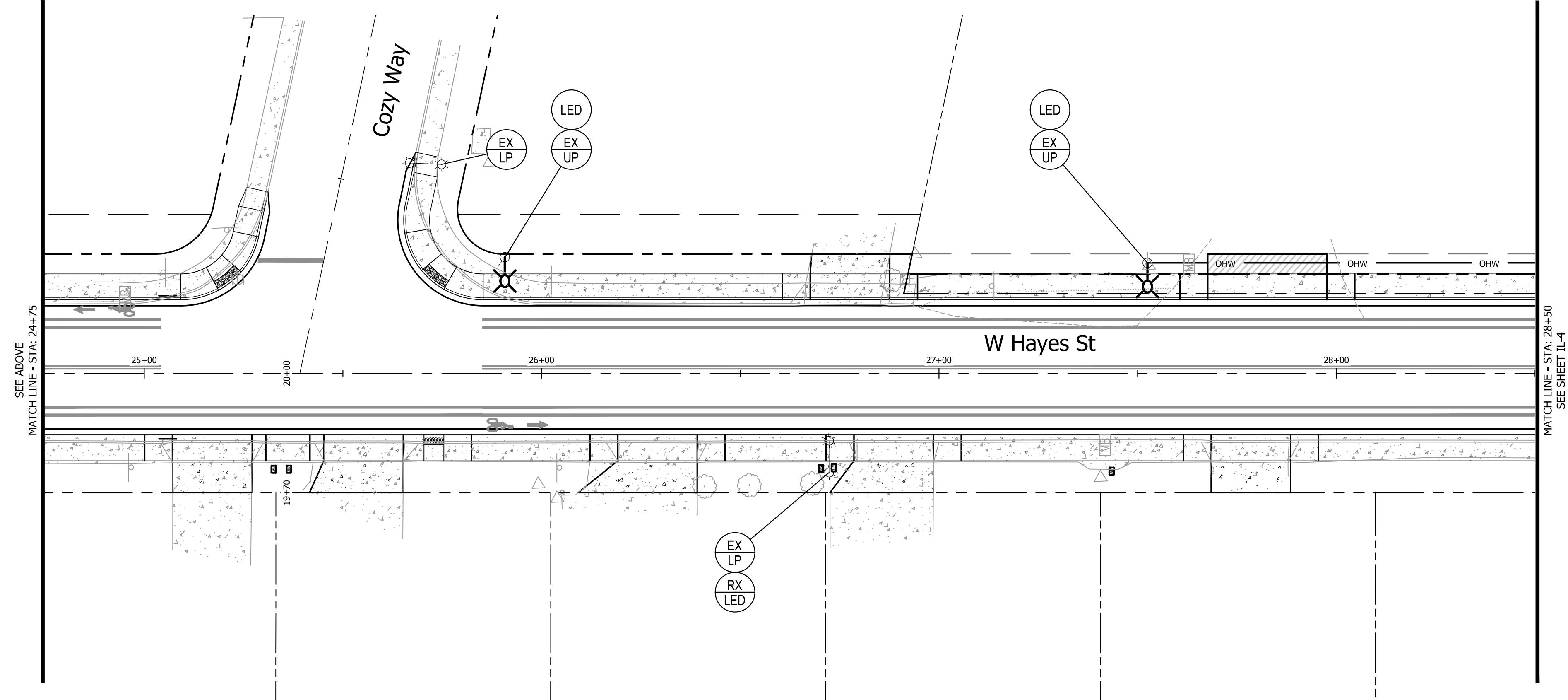
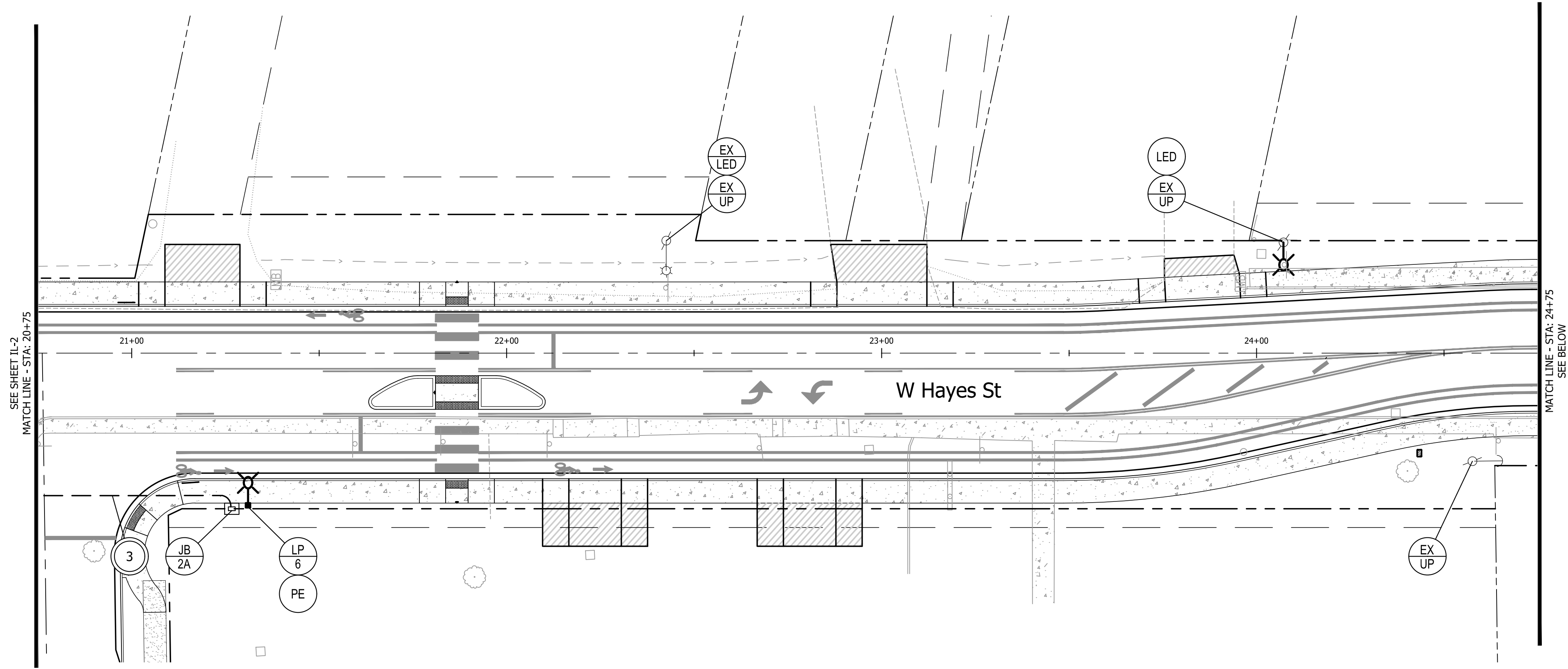

KITTELSON & ASSOCIATES
 851 SW 6TH AVENUE, SUITE 600
 PORTLAND, OR 97204
 P 503.228.5230 F 503.273.8169

#	DATE	REVISION	APP'D
0	05/25/22	ISSUE FOR CONSTRUCTION	FSW

Submission Date: 03/07/2022
 Drawn: JCB/RMM
 Designed: NRS/JBK
 Checked: FSW

PROJECT NO.
2015-001-20
W. Hayes Street Improvements
 Cascade Avenue to Settlemier Avenue
 ILLUMINATION PLAN

SHEET NO.
IL-3

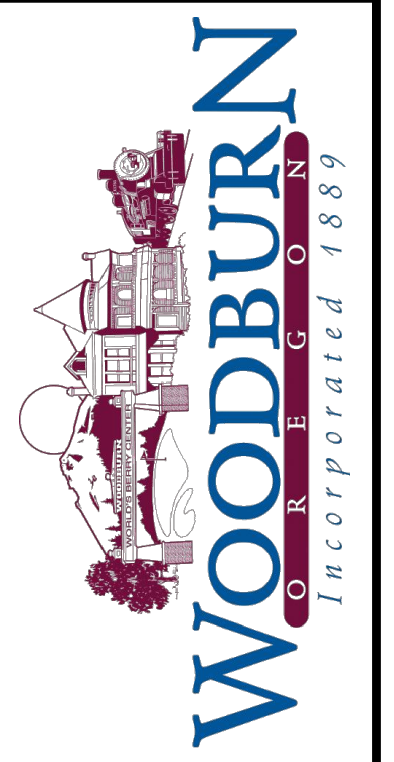
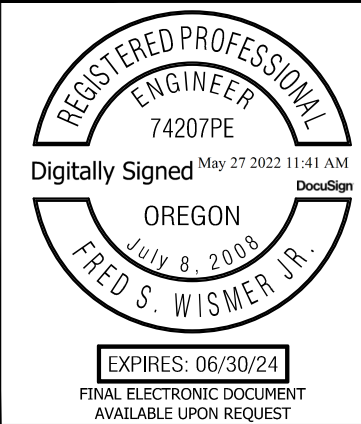
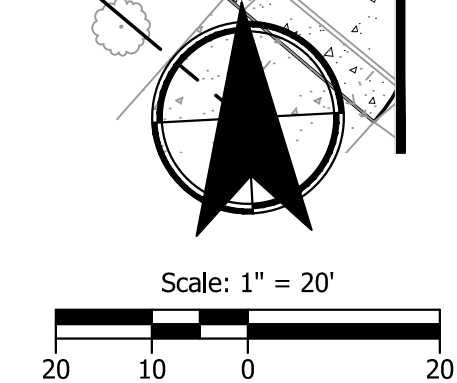
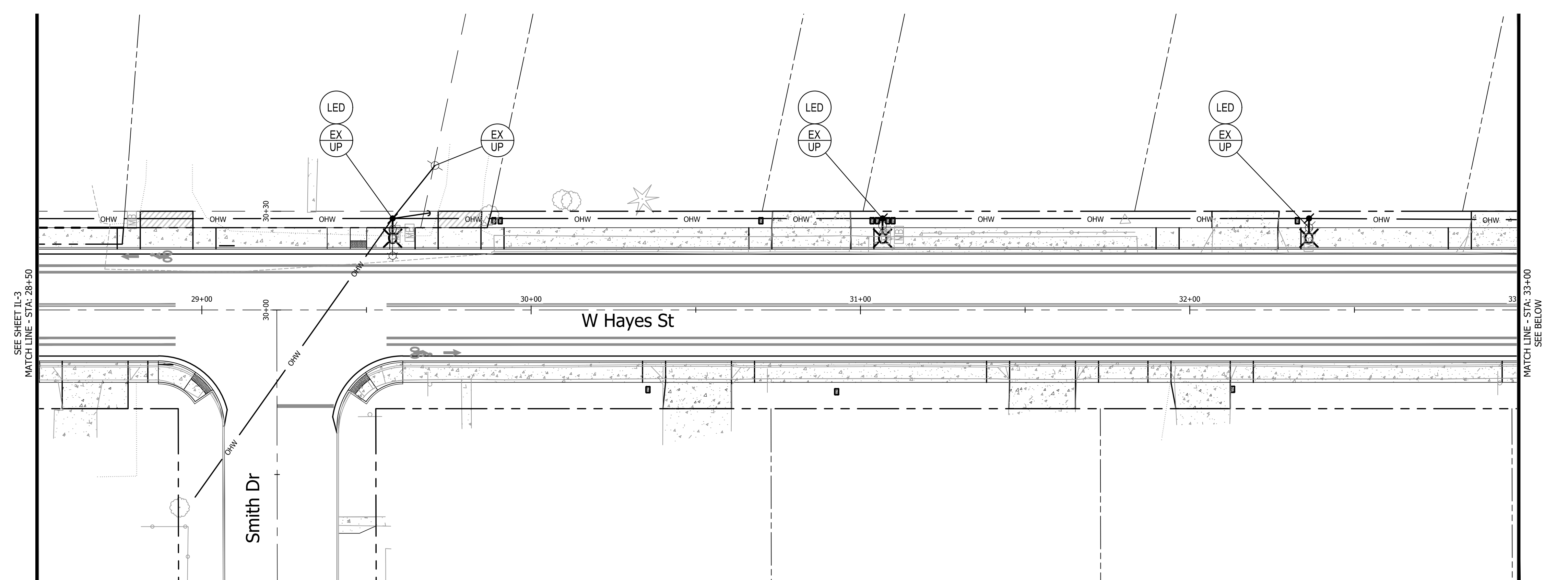
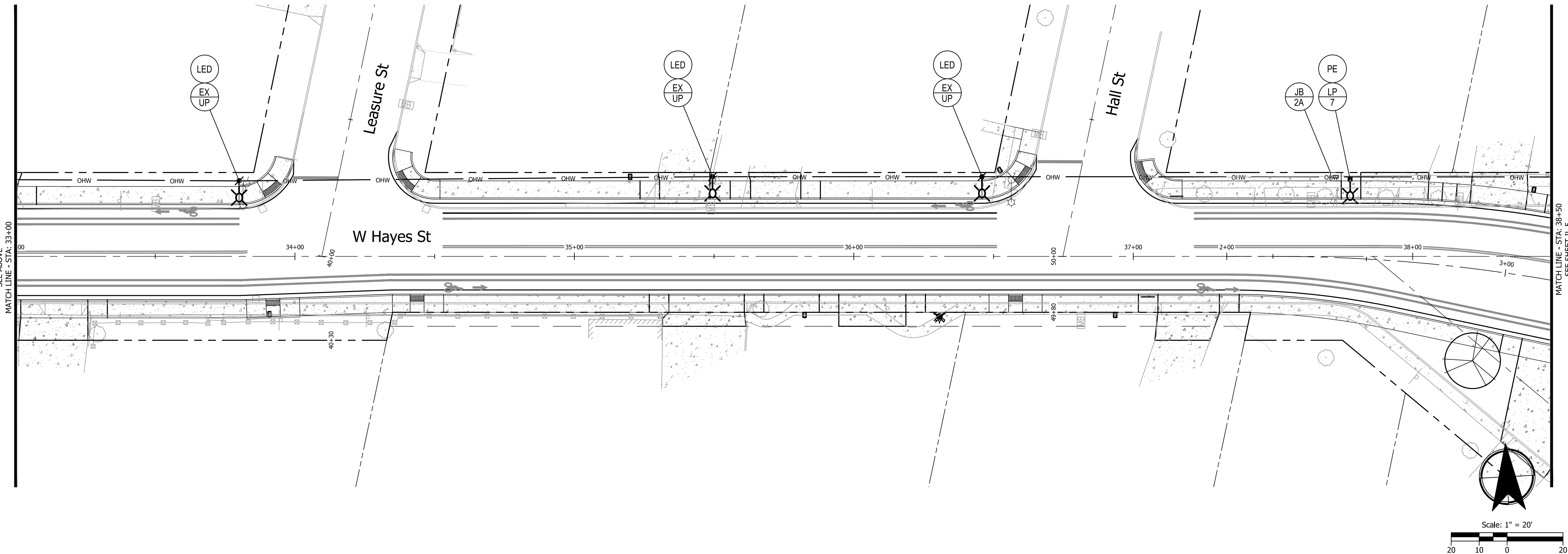

KITTELSON & ASSOCIATES
 851 SW 6TH AVENUE, SUITE 600
 PORTLAND, OR 97204
 P 503.228.5230 F 503.273.8169

#	DATE	REVISION	APP'D
0	05/25/22	ISSUE FOR CONSTRUCTION	FSW

Submission Date: 03/07/2022
 Drawn: JCB/RMM Designed: NRS/JBK Checked: FSW
 PROJECT NO. 2015-001-20

W. Hayes Street Improvements
 Cascade Avenue to Settlemier Avenue
 ILLUMINATION PLAN

SHEET NO. IL-4

Plot Stamp: 5/27/2022 11:39:45 AM - Fred Wismer
 File: H:\24\24512 - W. Hayes Street\design_CD\CD-Illumination-24512.dwg

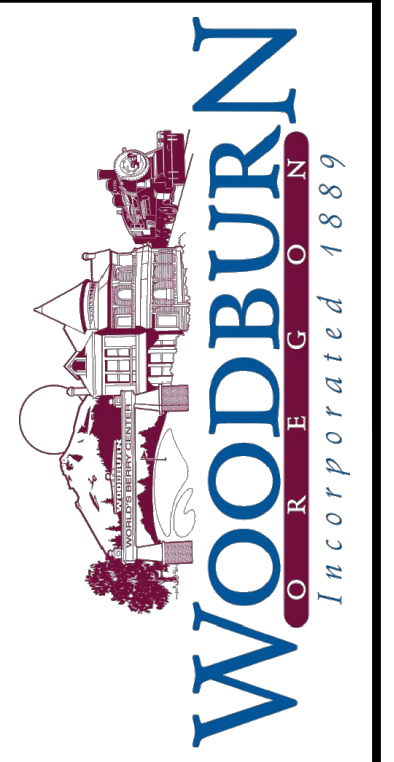
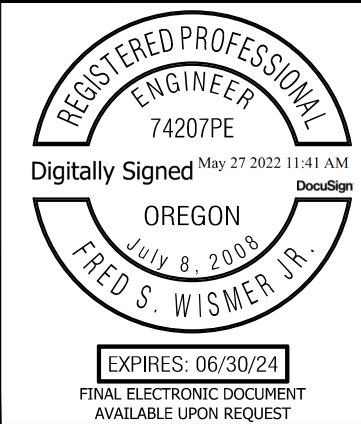
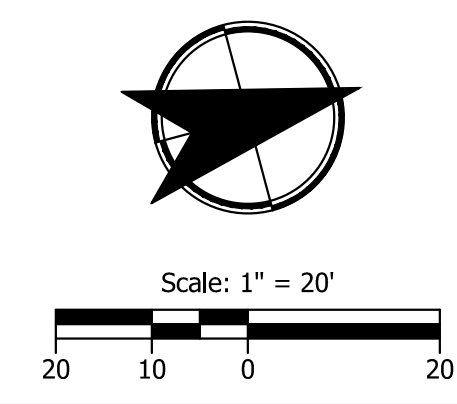
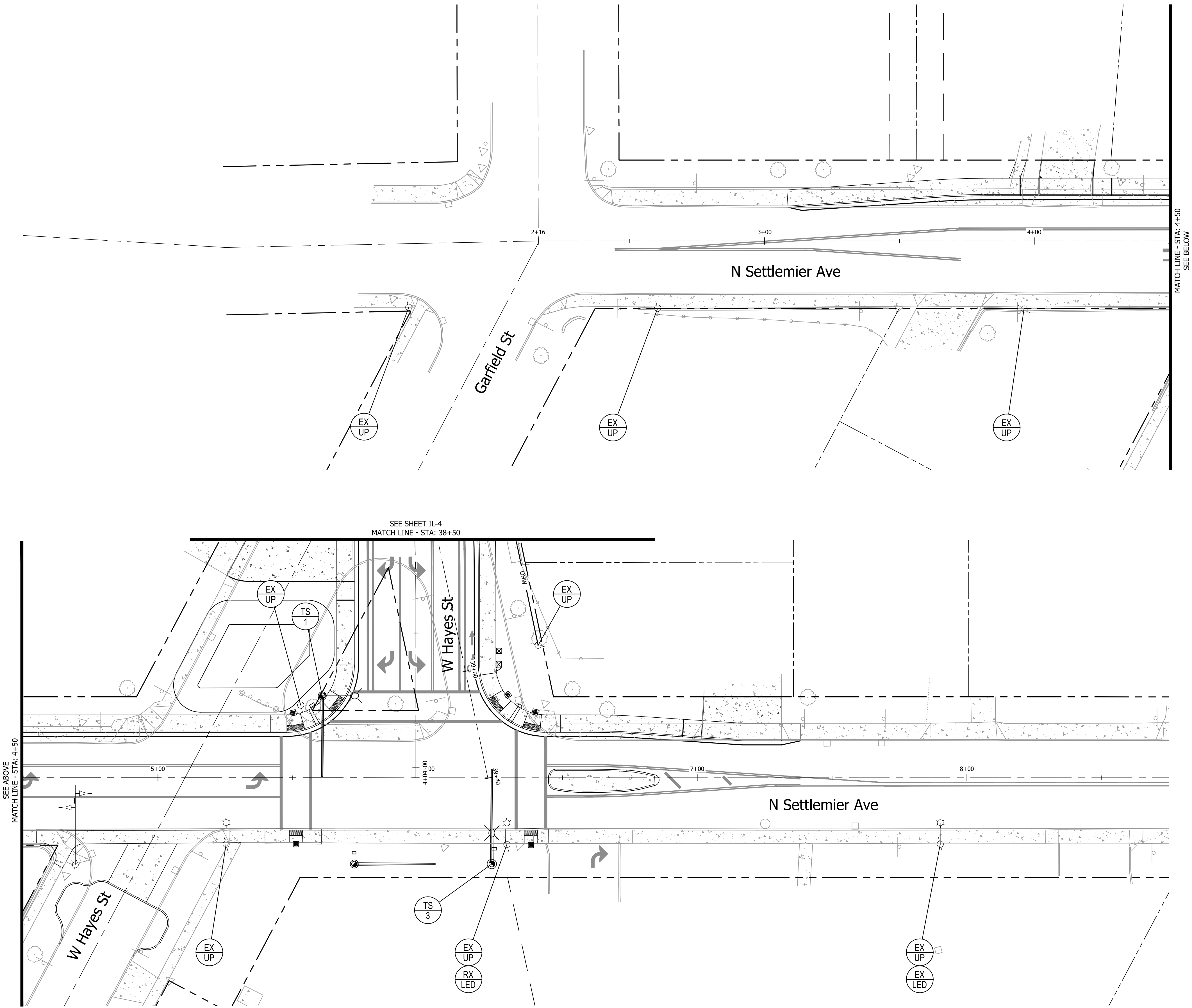

KITTELSON & ASSOCIATES
 851 SW 6TH AVENUE, SUITE 600
 PORTLAND, OR 97204
 P 503.228.5230 F 503.273.8169

#	DATE	REVISION	APP'D
0	05/25/22	ISSUE FOR CONSTRUCTION	FSW

Submission Date: 03/07/2022
 Drawn: JCB/RMM
 Designed: NRS/JBK
 Checked: FSW

PROJECT NO. 2015-001-20
W. Hayes Street Improvements
 Cascade Avenue to Settlemier Avenue
 ILLUMINATION PLAN
 SHEET NO. IL-5

EXPIRES: 06/30/24
 FINAL ELECTRONIC DOCUMENT
 AVAILABLE UPON REQUEST